FLEXI PRO Servo Drive

Quick Start Guide

Revision 5.6
Firmware 1.4.4



SEE IT BEFORE IT HAPPENS

**MOTOR
POWER**
COMPANY

Revision History

Doc. Rev.	Date	Remarks
5.6	Oct.2013	Updated: ordering info; pin assignments diagrams; controller and machine interface wiring diagrams; EnDat wiring; faults
5.4a/5.4b	July 2013	Miscellaneous corrections and updates
5.4	Mar. 2013	Miscellaneous corrections and updates.
5.3	Dec. 2012	Added and revised faults and warnings.
5.2	Dec. 2012	Added wiring for FLEXI PRO-020/FLEXI PRO-024 models.
5.0 / 5.1	Nov. 2012	Includes 120/240 VAC and 400/480 VAC models.
4.3	Aug. 2012	Warnings and faults updated.

Firmware Revision	Software (GUI) Revision
1.4.4	1.4.4.x

Note: If an earlier firmware revision is installed in you drive, contact your Account Manager or Technical Support.

Important Notice

© 2013 Motor Power Company s.r.l.

All rights reserved. No part of this work may be reproduced or transmitted in any form or by any means without prior written permission of Motor Power Company.

Disclaimer

The information in this manual was accurate and reliable at the time of its release. Motor Power Company s.r.l. reserves the right to change the specifications of the product described in this manual without notice at any time.

Trademarks

CANopen and CiA are registered trademarks of the CAN in Automation User's Group

EtherCAT is a registered trademark and patented technology, licensed by Beckhoff Automation GmbH

EnDat is a registered trademark of Dr. Johannes Heidenhain GmbH

HIPERFACE is a registered trademark of Sick Stegmann GmbH

Windows is a registered trademark of Microsoft Corporation

Contact Information

Motor Power Company s.r.l.
 Via Leonardo Da Vinci , 4
 42024 Castelnovo Sotto
 Reggio Emilia - Italia

Tel: +39 0522 682710
 Fax: +39 0522 683552

Website : www.motorpowerco.com

Technical Support

If you need assistance with the installation and configuration of the FLEXI PRO drive, contact Motor Power Company technical support: info@motorpowerco.it

Part Number

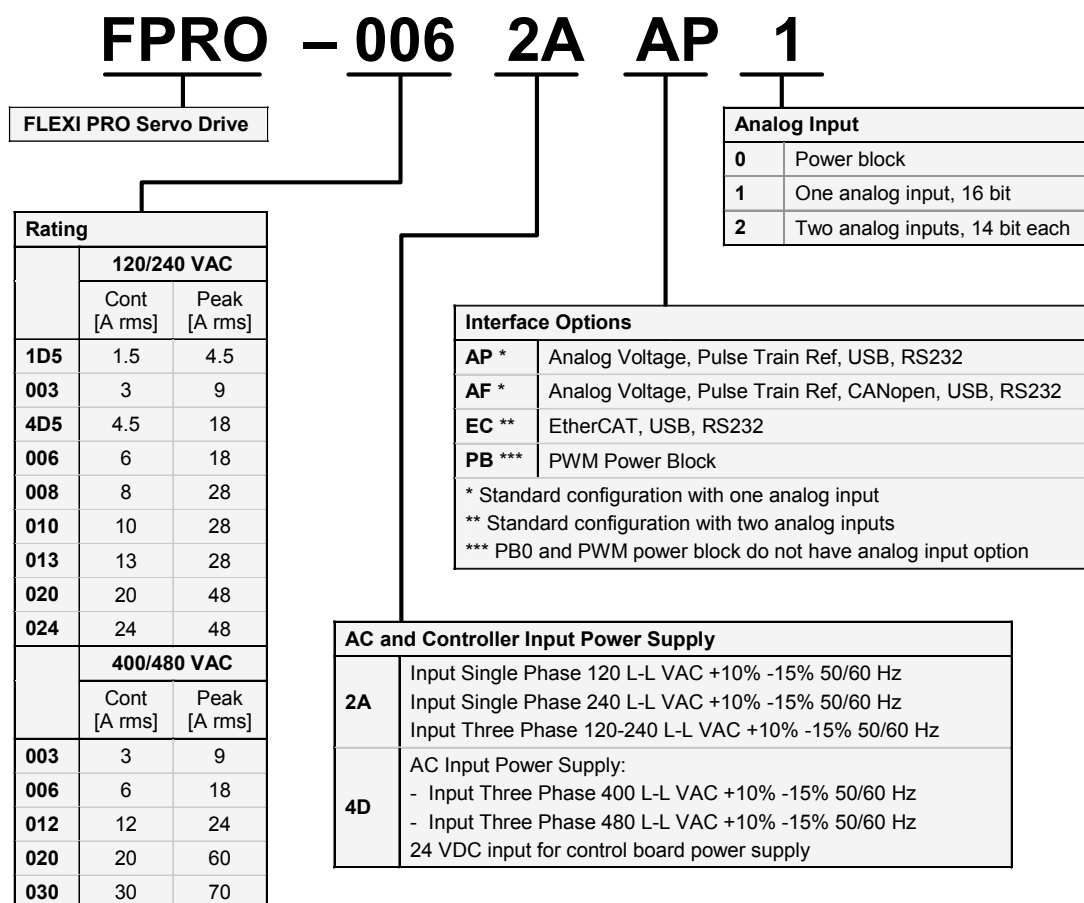

Contents

1 Introduction	7
FLEXI PRO Documentation	7
Safety	7
Required Hardware and Tools	7
Required Computer System	8
FLEXI PRO Installation Procedure	8
FLEXI PRO Dimensions and Mounting	9
FLEXI PRO Wiring and Pin Assignments	12
2 Control Board	24
Overview	24
Controller I/Os – C2	24
Controller Interface Wiring	27
Machine I/Os – C3	29
Machine Interface Wiring	31
Motor Feedback – C4	33
Feedback Wiring Guidelines	34
Fieldbus Devices – C5 and C6	43
CANopen Communication	43
EtherCAT Communication	43
Host Computer – C1, C7	44
Daisy Chain – C8	45
Drive Address Switches	46
3 Power Board 120/240 VAC	47
Overview	47
Safe Torque Off (STO) – P1	47
Motor – P2	48
Regeneration Resistor – P3	49
AC Input – P3, P4, P5	50
4 Power Board 400/480 VAC	52
Overview	52
Safe Torque Off (STO) – P1	52
Logic Power 24V Input – P2	53
AC Input and Regeneration Resistor – P3	54
Brake – P4	55
Motor – P5	56
5 Software	57
FLEXI SUITE Installation	57
Power Up	57
Drive Configuration	58
6 Drive Status	59
Normal Operation Codes	59
Warning and Fault Codes	60

1 Introduction

FLEXI PRO Documentation

This manual is part of a documentation set. The entire set consists of the following:

- FLEXI PRO Quick Start Guide. Basic setup and operation of the drive.
- FLEXI PRO User Manual. Hardware installation, configuration and operation.
- FLEXI PRO VarCom Reference Manual. Parameters and commands used to program the FLEXI PRO.
- FLEXI PRO CANopen for CAN and EtherCAT Drives Reference Manual. FLEXI PRO implementation of CANopen protocol for CAN and EtherCAT.

Safety

Only qualified persons may perform the installation procedures. You do not need to be an expert in motion control to install and operate the drive system. However, you must have a basic understanding of electronics, computers, mechanics, and safety practices.



**The FLEXI PRO utilizes hazardous voltages.
Be sure the drive is properly grounded.**

Before you install the FLEXI PRO, review the safety instructions in this manual. The manual is available as a PDF file that can be downloaded from the Motor Power Company website.

Failure to follow the safety instructions may result in personal injury or equipment damage.

Required Hardware and Tools

All required hardware and tools are specified in the diagrams in the section FLEXI PRO Wiring and Pin Assignments.

The connectors and tools that are supplied with the FLEXI PRO are also indicated in those diagrams.

In addition, you will need a small slotted screwdriver for setting switches.

To connect the FLEXI PRO to the host computer via serial communication, you will need one of the following:

- USB 2.0 A to Mini-B cable (USB interface)
- 4p4c plug and cable (RS232 interface)

To connect the FLEXI PRO to the host computer or host PLC via fieldbus, you will need:

- RJ45 cables (CAN interface or EtherCAT)

Required Computer System

The following computer system and software are required:

- 2 GHz CPU
- 1 MB RAM
- 1000 MB available on hard drive (after .net 4 is installed)
- USB or RS232 port for connecting to the drive, according to FLEXI PRO model.
- Operating system: Windows XP-SP3, or Windows 7
- Recommended screen resolution for FLEXI SUITE is 1280x800. Minimal resolution is 1024x768.
- FLEXI SUITE, the graphical software interface for configuring and testing the drive. Download from the Motor Power Company website or contact Technical Support.
- .Net4 (for details, refer to .NET Framework System Requirements). If .NET 4 is not installed on the computer, FLEXI SUITE will guide you through the installation, but will not install it automatically.

FLEXI PRO Installation Procedure

Perform the following steps to install and setup a FLEXI PRO system.

1. Mount the FLEXI PRO.
2. Make all electrical connections:
 - Controller I/Os and/or Machine I/Os
 - Motor feedback
 - Fieldbus devices, if required
 - Safe torque off (STO), or bypass using jumpers
 - Motor
 - Motor brake, if required
 - Regeneration resistor, if required
 - AC input voltage
3. Set the drive address using the rotary switches.
4. Connect the drive to the PC.
5. Power up the drive and the PC.
6. Install FLEXI SUITE software.
7. Using FLEXI SUITE, configure and test the drive.

FLEXI PRO Dimensions and Mounting

Using the bracket on the back of the FLEXI PRO, mount the FLEXI PRO on a grounded conductive metal panel.

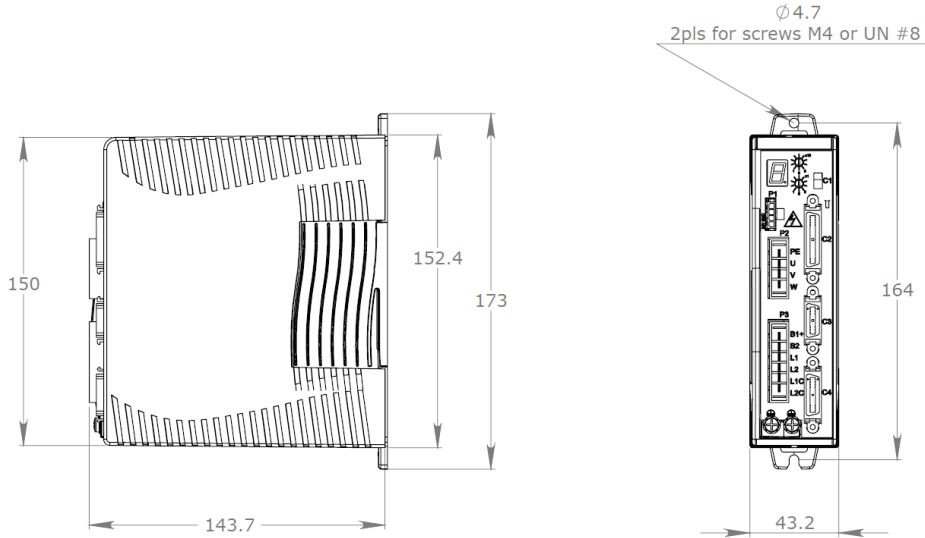

FLEXI PRO-1D5/FLEXI PRO-003 – 120/240 VAC - Dimensions (mm)
Note: FLEXI PRO-003 has fan.

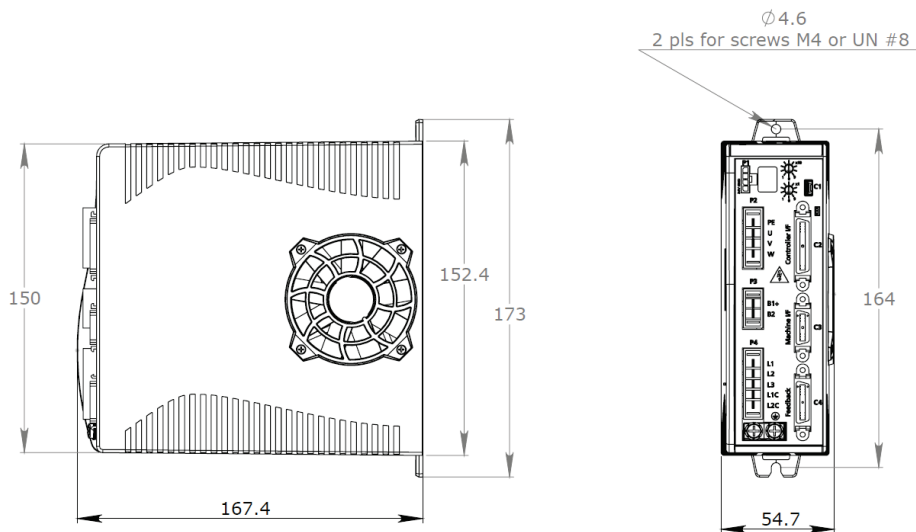

FLEXI PRO-4D5/FLEXI PRO-006 – 120/240 VAC - Dimensions (mm)

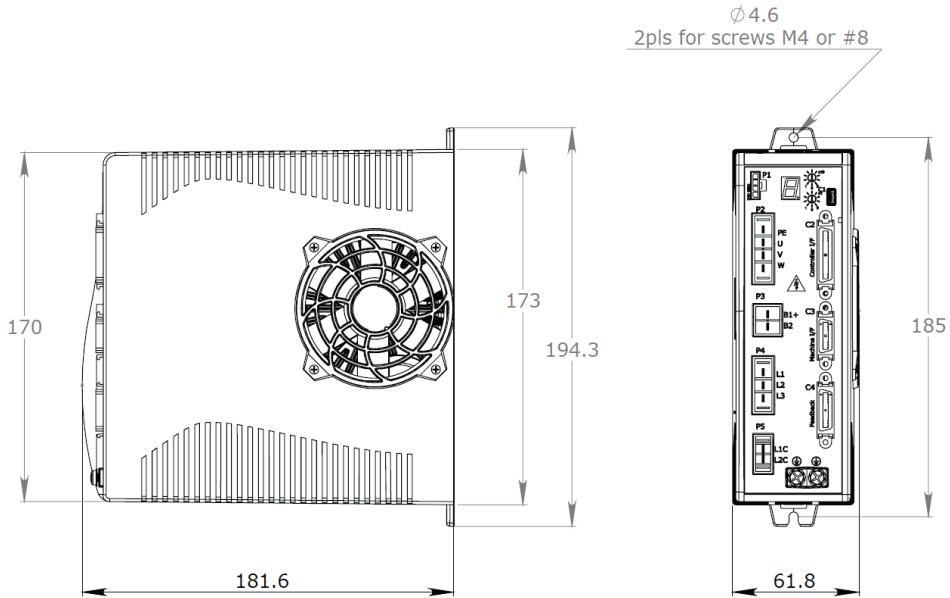

FLEXI PRO-008/FLEXI PRO-010/FLEXI PRO-013 – 120/240 VAC - Dimensions (mm)

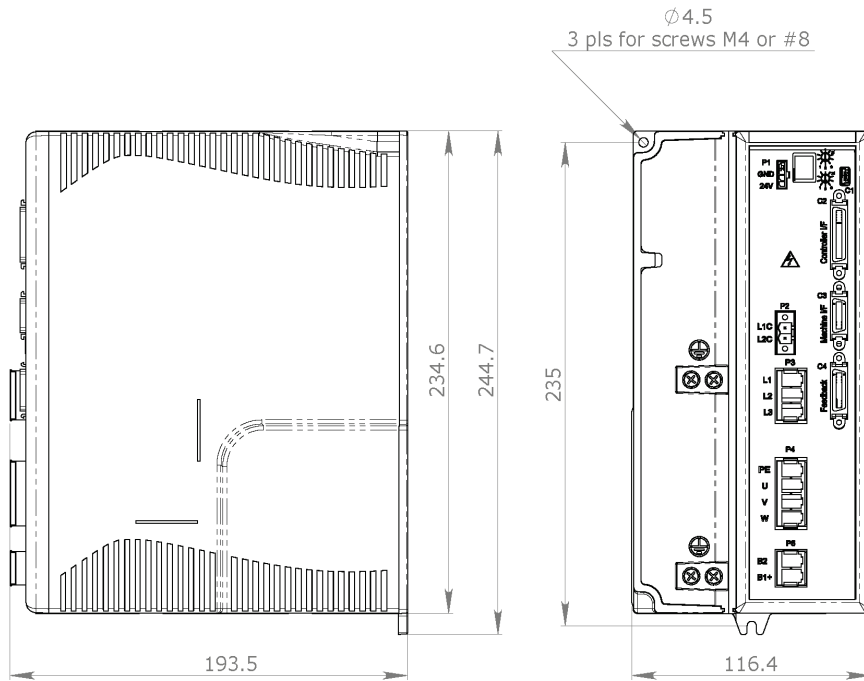

FLEXI PRO-020/FLEXI PRO-024 – 120/240 VAC - Dimensions (mm)

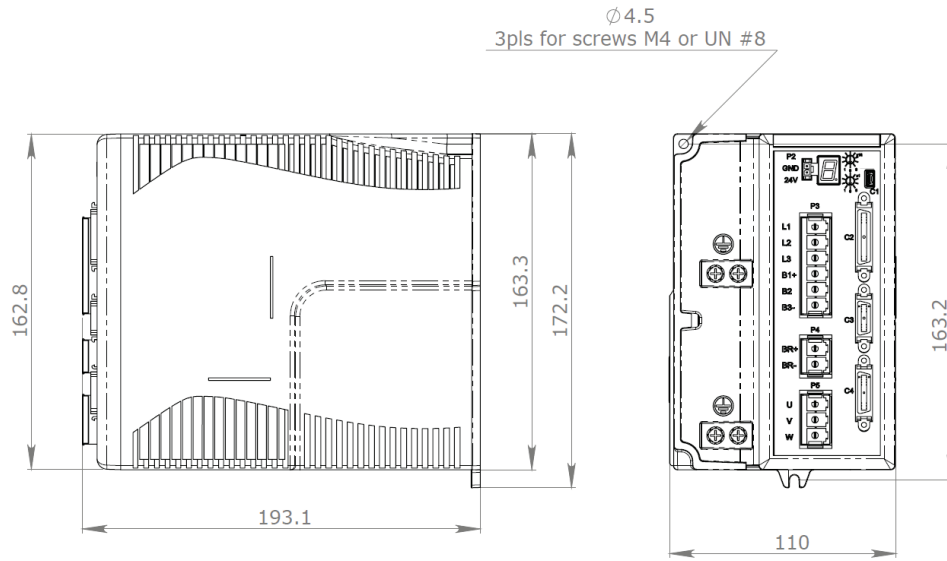

FLEXI PRO-003/FLEXI PRO-006 – 400/480 VAC - Dimensions (mm)

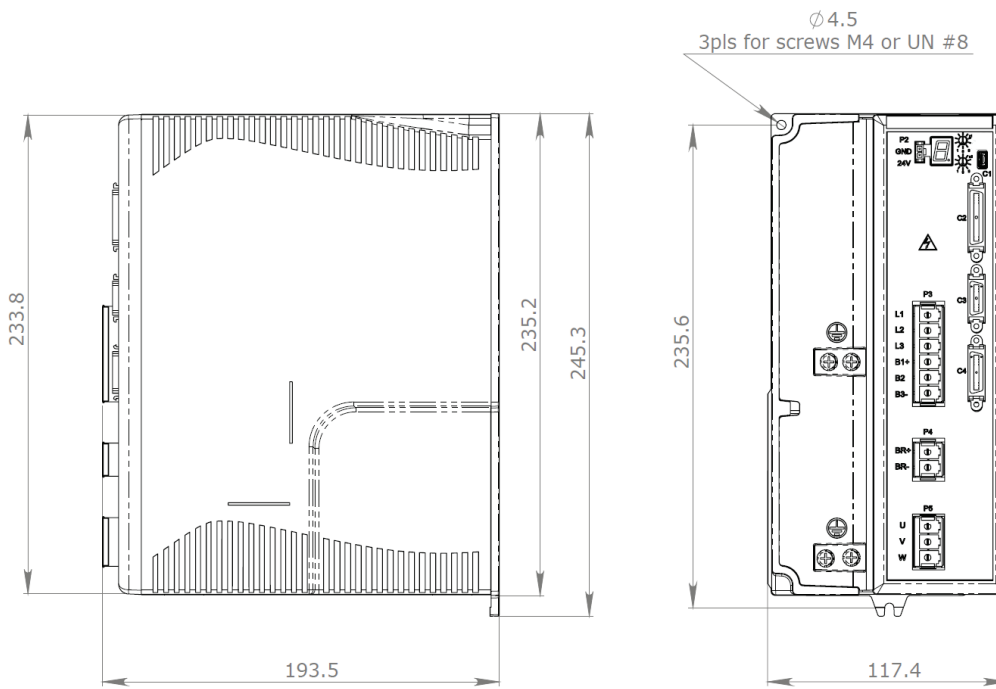

FLEXI PRO-012 - 400/480 VAC - Dimensions (mm)

FLEXI PRO Wiring and Pin Assignments

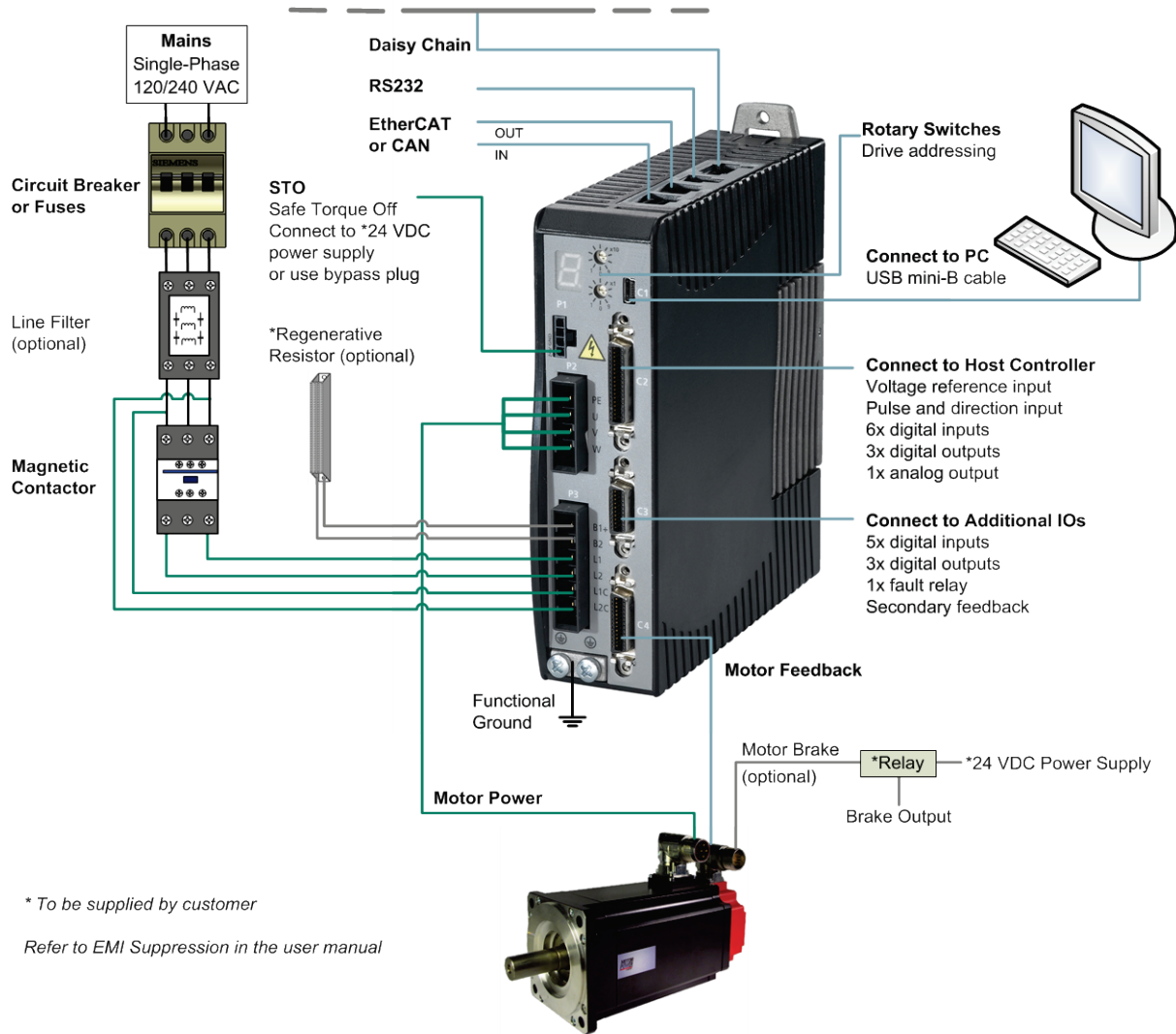

FLEXI PRO-1D5/FLEXI PRO-003 – Servo System Wiring –120/240 VAC, 1-Phase

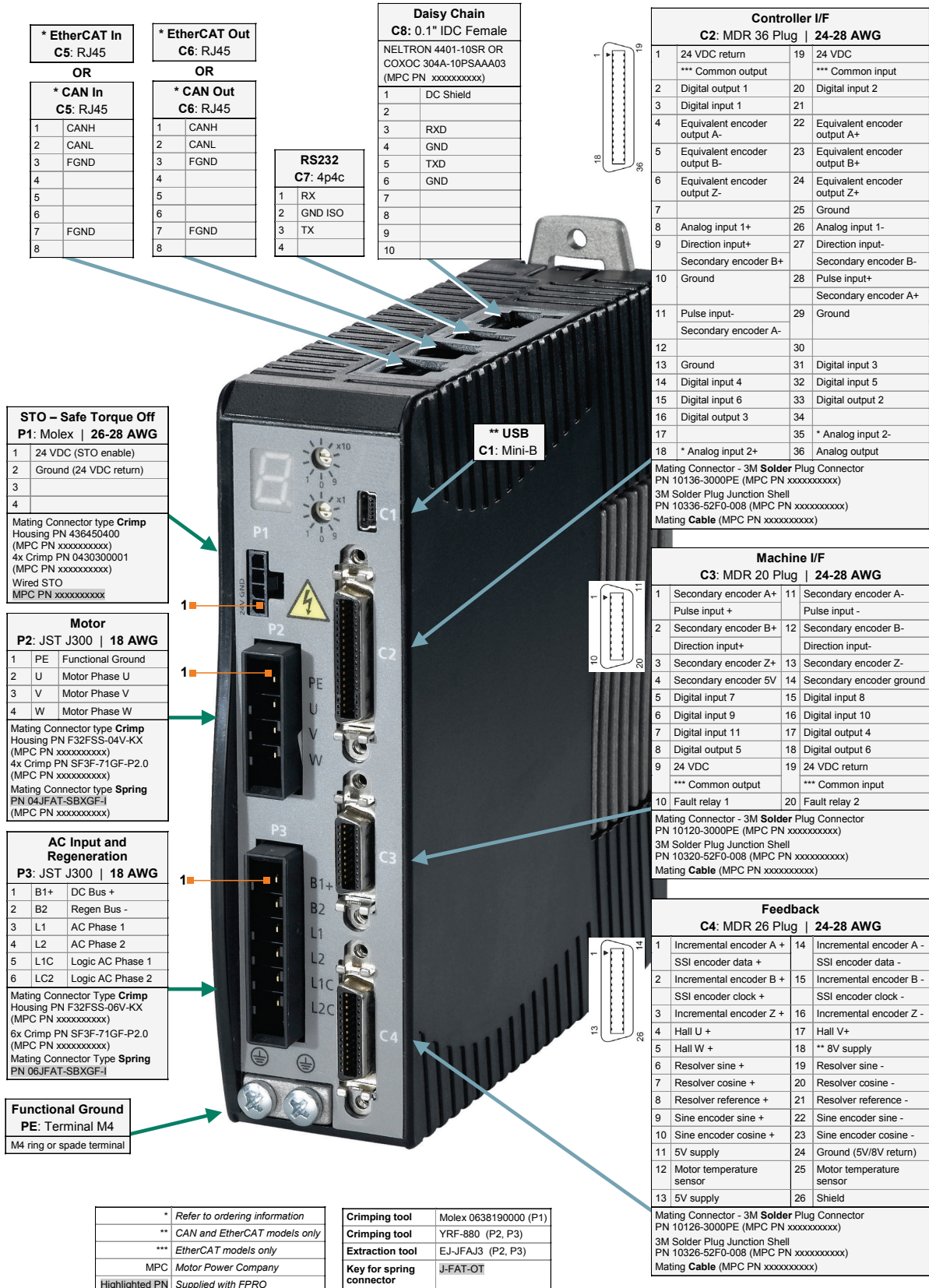

FLEXI PRO-1D5/FLEXI PRO-003 – Pin Assignments – 120/240 VAC

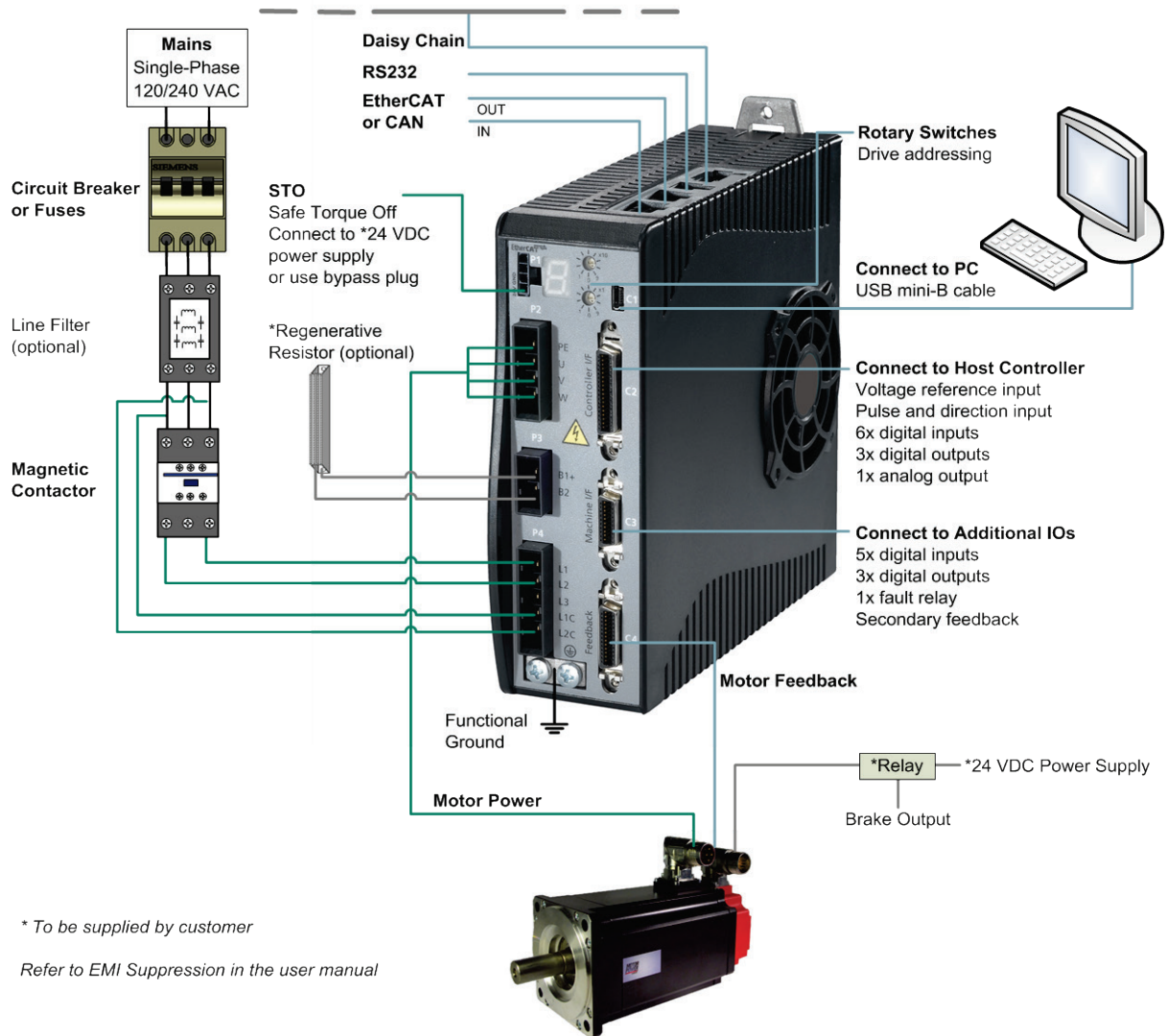

FLEXI PRO-4D5/FLEXI PRO-006 – Servo System Wiring – 120/240 VAC, 1-Phase

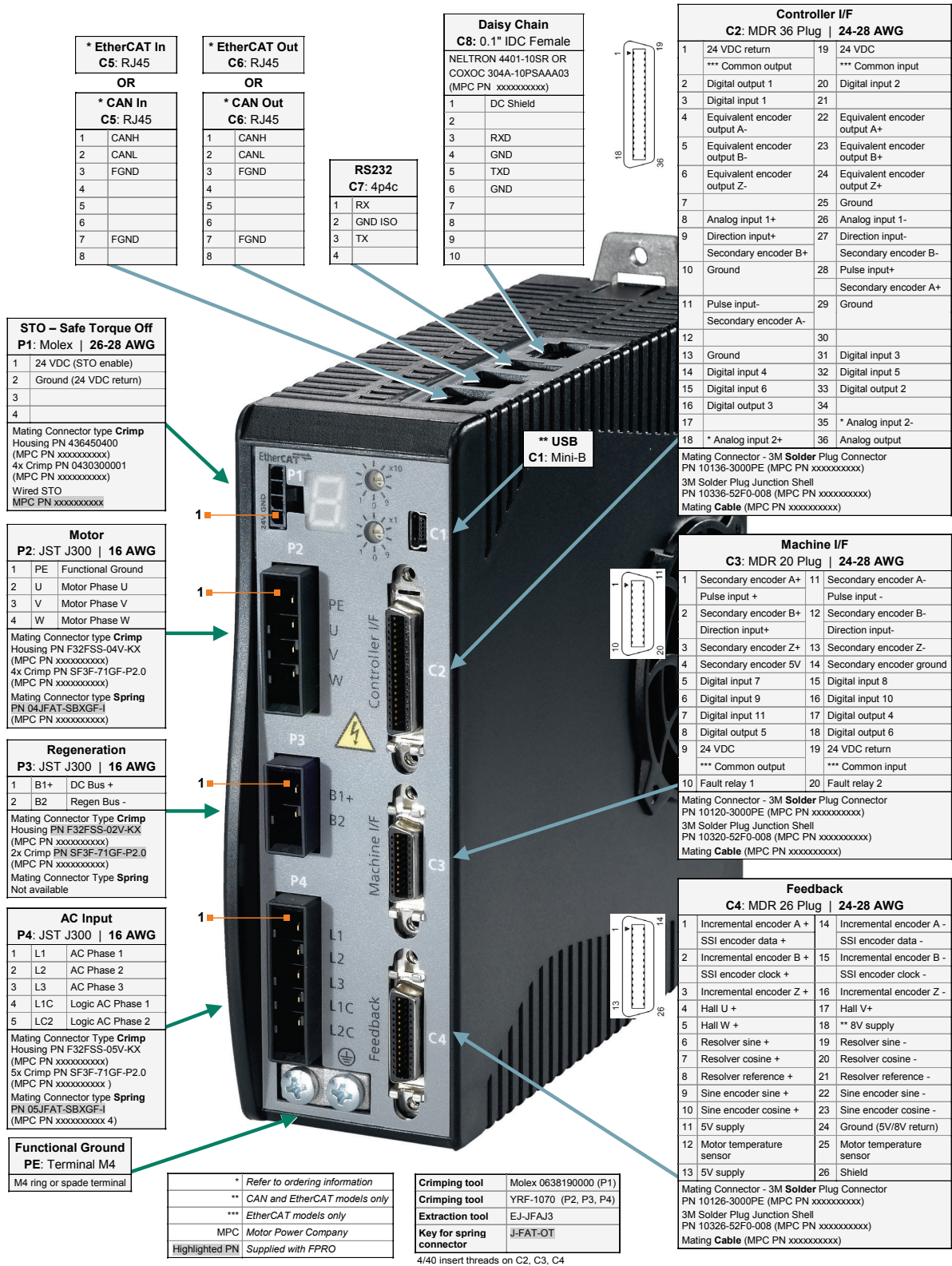

*** EtherCAT In**
C5: RJ45

OR

*** CAN In**
C5: RJ45

1	CANH
2	CANL
3	FGND
4	
5	
6	
7	FGND
8	

*** EtherCAT Out**
C6: RJ45

OR

*** CAN Out**
C6: RJ45

1	CANH
2	CANL
3	FGND
4	
5	
6	
7	FGND
8	

RS232
C7: 4p4c

1	RX
2	GND ISO
3	TX
4	

Daisy Chain
C8: 0.1" IDC Female

NELTRON 4401-10SR OR
COXOC 304A-10PSAA03
(MPC PN xxxxxxxxx)

1	DC Shield
2	
3	RXD
4	GND
5	TXD
6	GND
7	
8	
9	
10	

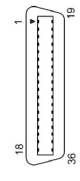

STO – Safe Torque Off
P1: Molex | 26-28 AWG

1	24 VDC (STO enable)
2	Ground (24 VDC return)
3	
4	

Mating Connector type Crimp
Housing PN 436450400
(MPC PN xxxxxxxxx)
4x Crimp PN 0430300001
(MPC PN xxxxxxxxx)
Wired STO
MPC PN xxxxxxxxx

Motor
P2: JST J300 | 16 AWG

1	PE	Functional Ground
2	U	Motor Phase U
3	V	Motor Phase V
4	W	Motor Phase W

Mating Connector type Crimp
Housing PN F32FSS-04V-KX
(MPC PN xxxxxxxxx)
4x Crimp PN SF3F-71GF-P2.0
(MPC PN xxxxxxxxx)
Mating Connector type Spring
PN 04JFAT-SBXGF-I
(MPC PN xxxxxxxxx)

Regeneration
P3: JST J300 | 16 AWG

1	B1+	DC Bus +
2	B2	Regen Bus -

Mating Connector Type Crimp
Housing PN F32FSS-02V-KX
(MPC PN xxxxxxxxx)
2x Crimp PN SF3F-71GF-P2.0
(MPC PN xxxxxxxxx)
Mating Connector Type Spring
Not available

AC Input
P4: JST J300 | 16 AWG

1	L1	AC Phase 1
2	L2	AC Phase 2
3	L3	AC Phase 3
4	L1C	Logic AC Phase 1
5	LC2	Logic AC Phase 2

Mating Connector Type Crimp
Housing PN F32FSS-05V-KX
(MPC PN xxxxxxxxx)
5x Crimp PN SF3F-71GF-P2.0
(MPC PN xxxxxxxxx)
Mating Connector type Spring
PN 05JFAT-SBXGF-I
(MPC PN xxxxxxxxx 4)

Functional Ground
PE: Terminal M4

M4 ring or spade terminal

* Refer to ordering information
** CAN and EtherCAT models only
*** EtherCAT models only
MPC Motor Power Company
Highlighted PN Supplied with FPRO

Crimping tool Molex 0638190000 (P1)
Crimping tool YRF-1070 (P2, P3, P4)
Extraction tool EJ-JFAJ3
Key for spring connector J-FAT-OT

4/40 insert threads on C2, C3, C4

Controller I/F
C2: MDR 36 Plug | 24-28 AWG

1	24 VDC return	19	24 VDC
2	Digital output 1	20	Digital input 2
3	Digital input 1	21	
4	Equivalent encoder output A-	22	Equivalent encoder output A+
5	Equivalent encoder output B-	23	Equivalent encoder output B+
6	Equivalent encoder output Z-	24	Equivalent encoder output Z+
7		25	Ground
8	Analog input 1+	26	Analog input 1-
9	Direction input+ Secondary encoder B+	27	Direction input- Secondary encoder B-
10	Ground	28	Pulse input+ Secondary encoder A+
11	Pulse input- Secondary encoder A-	29	Ground
12		30	
13	Ground	31	Digital input 3
14	Digital input 4	32	Digital input 5
15	Digital input 6	33	Digital output 2
16	Digital output 3	34	
17		35	* Analog input 2-
18	* Analog input 2+	36	Analog output

Mating Connector - 3M Solder Plug Connector
PN 10136-3000PE (MPC PN xxxxxxxxx)
3M Solder Plug Junction Shell
PN 10326-52F0-008 (MPC PN xxxxxxxxx)
Mating Cable (MPC PN xxxxxxxxx)

Machine I/F
C3: MDR 20 Plug | 24-28 AWG

1	Secondary encoder A+ Pulse input +	11	Secondary encoder A- Pulse input -
2	Secondary encoder B+ Direction input+	12	Secondary encoder B- Direction input-
3	Secondary encoder Z+	13	Secondary encoder Z-
4	Secondary encoder 5V	14	Secondary encoder ground
5	Digital input 7	15	Digital input 8
6	Digital input 9	16	Digital input 10
7	Digital input 11	17	Digital output 4
8	Digital output 5	18	Digital output 6
9	24 VDC	19	24 VDC return
10	*** Common output	20	*** Common input
11	Fault relay 1	21	Fault relay 2

Mating Connector - 3M Solder Plug Connector
PN 10120-3000PE (MPC PN xxxxxxxxx)
3M Solder Plug Junction Shell
PN 10320-52F0-008 (MPC PN xxxxxxxxx)
Mating Cable (MPC PN xxxxxxxxx)

Feedback
C4: MDR 26 Plug | 24-28 AWG

1	Incremental encoder A + SSI encoder data +	14	Incremental encoder A - SSI encoder data -
2	Incremental encoder B + SSI encoder clock +	15	Incremental encoder B - SSI encoder clock -
3	Incremental encoder Z +	16	Incremental encoder Z -
4	Hall U +	17	Hall V+
5	Hall W +	18	** 8V supply
6	Resolver sine +	19	Resolver sine -
7	Resolver cosine +	20	Resolver cosine -
8	Resolver reference +	21	Resolver reference -
9	Sine encoder sine +	22	Sine encoder sine -
10	Sine encoder cosine +	23	Sine encoder cosine -
11	5V supply	24	Ground (5V/8V return)
12	Motor temperature sensor	25	Motor temperature sensor
13	5V supply	26	Shield

Mating Connector - 3M Solder Plug Connector
PN 10126-3000PE (MPC PN xxxxxxxxx)
3M Solder Plug Junction Shell
PN 10326-52F0-008 (MPC PN xxxxxxxxx)
Mating Cable (MPC PN xxxxxxxxx)

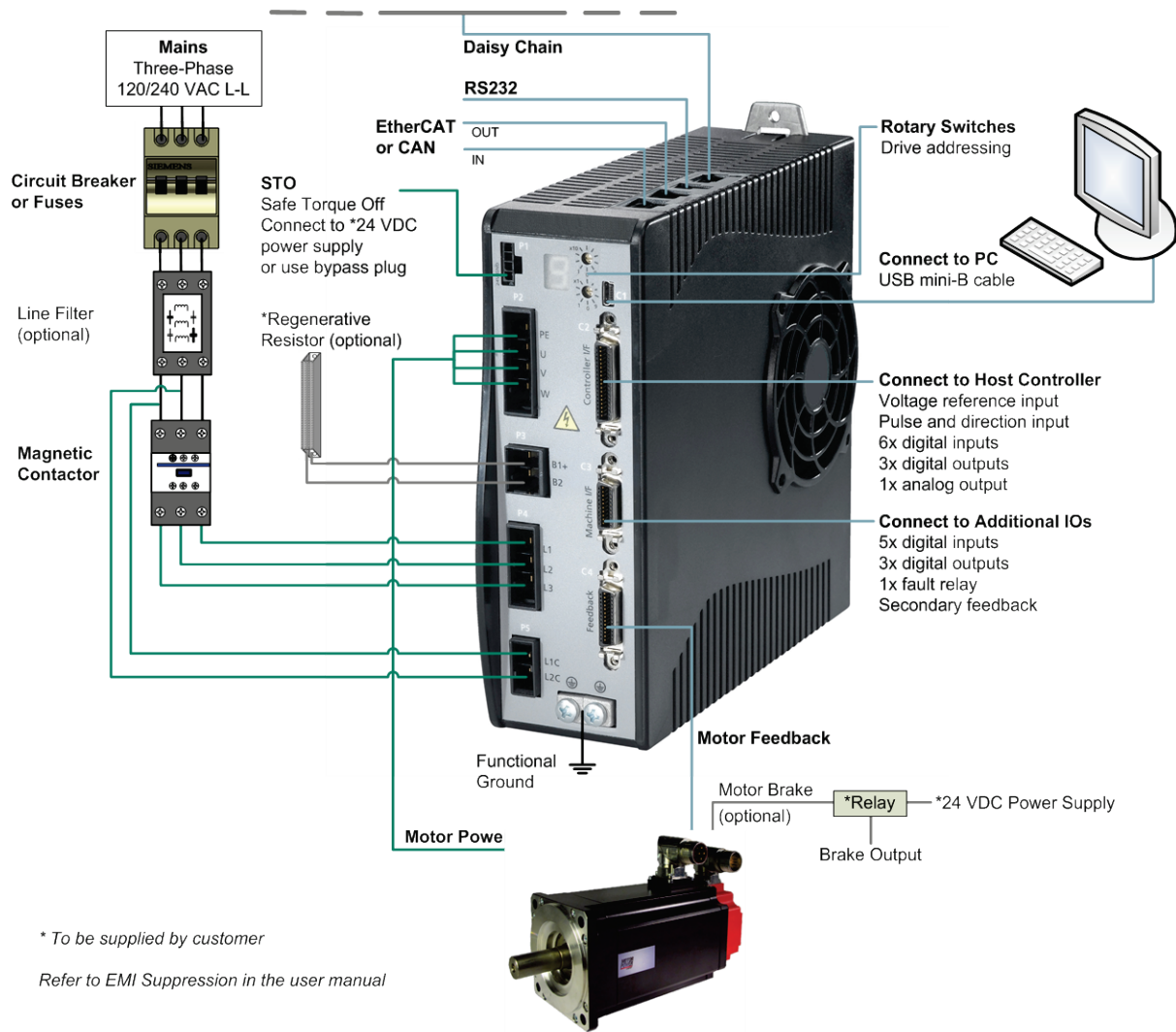

* To be supplied by customer
 Refer to EMI Suppression in the user manual

FLEXI PRO-008/FLEXI PRO-010/FLEXI PRO-013 – Servo System Wiring – 120/240 VAC, 3-Phase

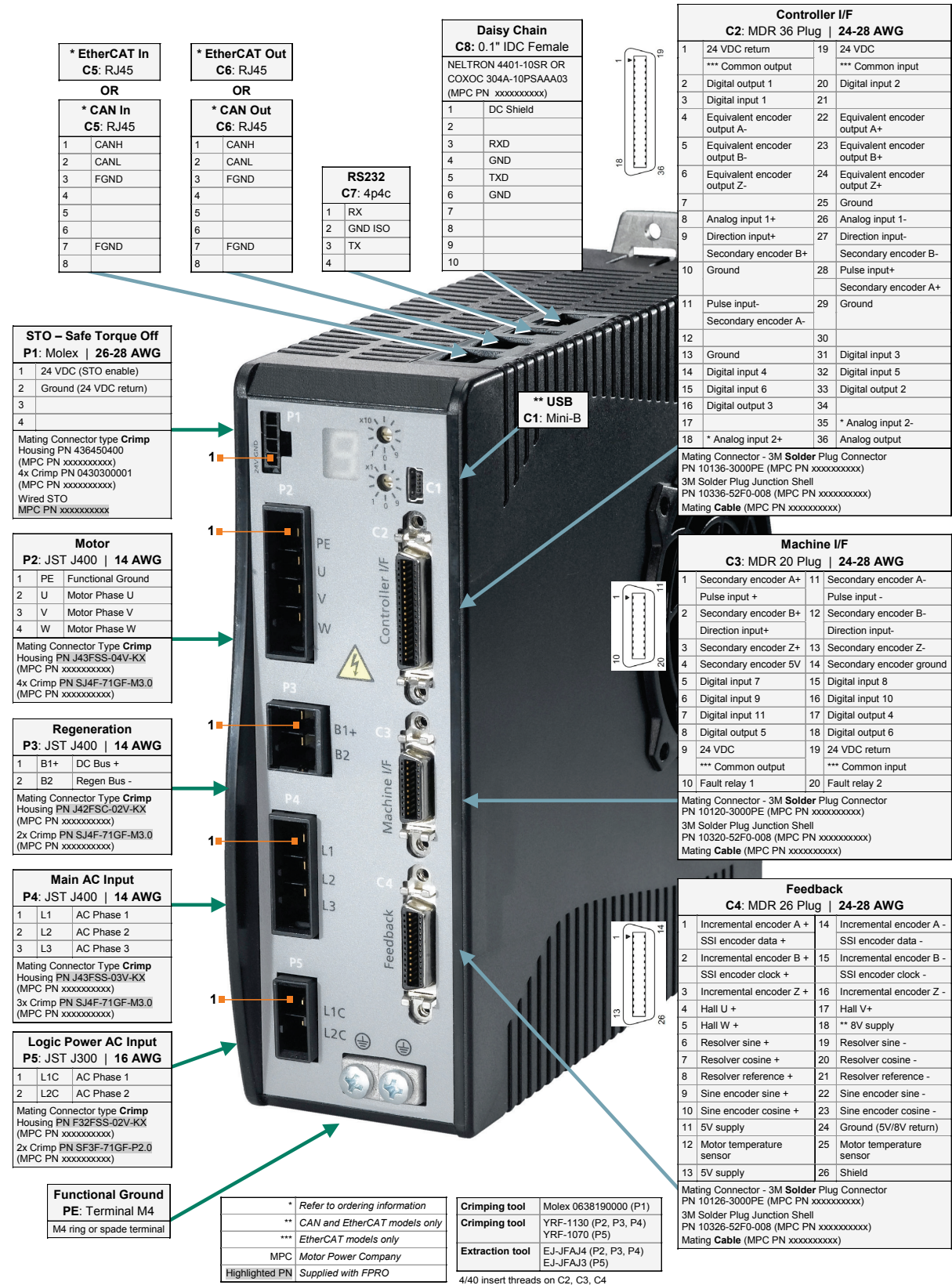

FLEXI PRO-008/FLEXI PRO-010/FLEXI PRO-013 – Pin Assignments – 120/240 VAC

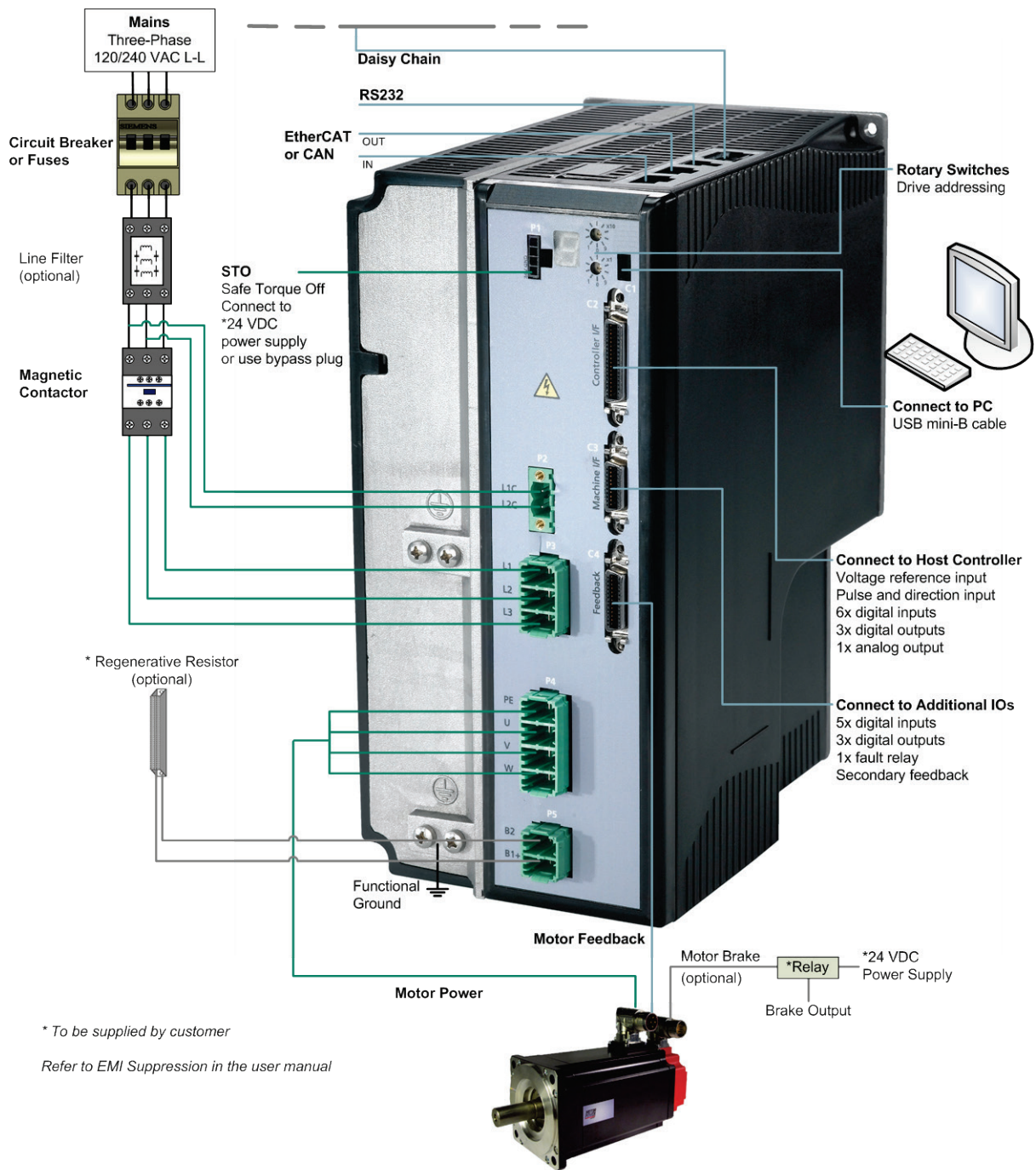

* To be supplied by customer

Refer to EMI Suppression in the user manual

FLEXI PRO-020/FLEXI PRO-024 – Servo System Wiring – 120/240 VAC, 3-Phase

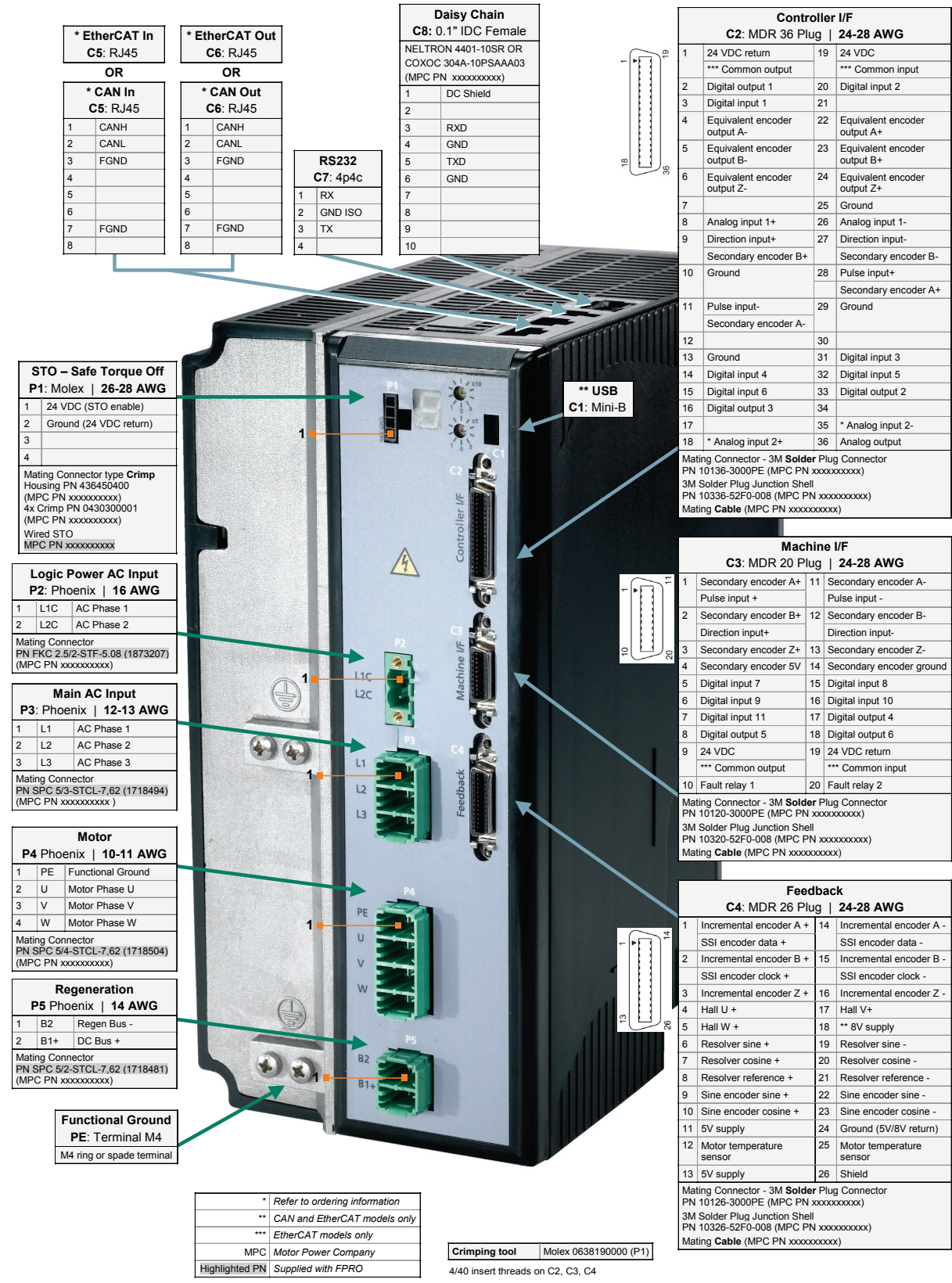

FLEXI PRO-020/FLEXI PRO-024 - Pin Assignments - 120/240 VAC

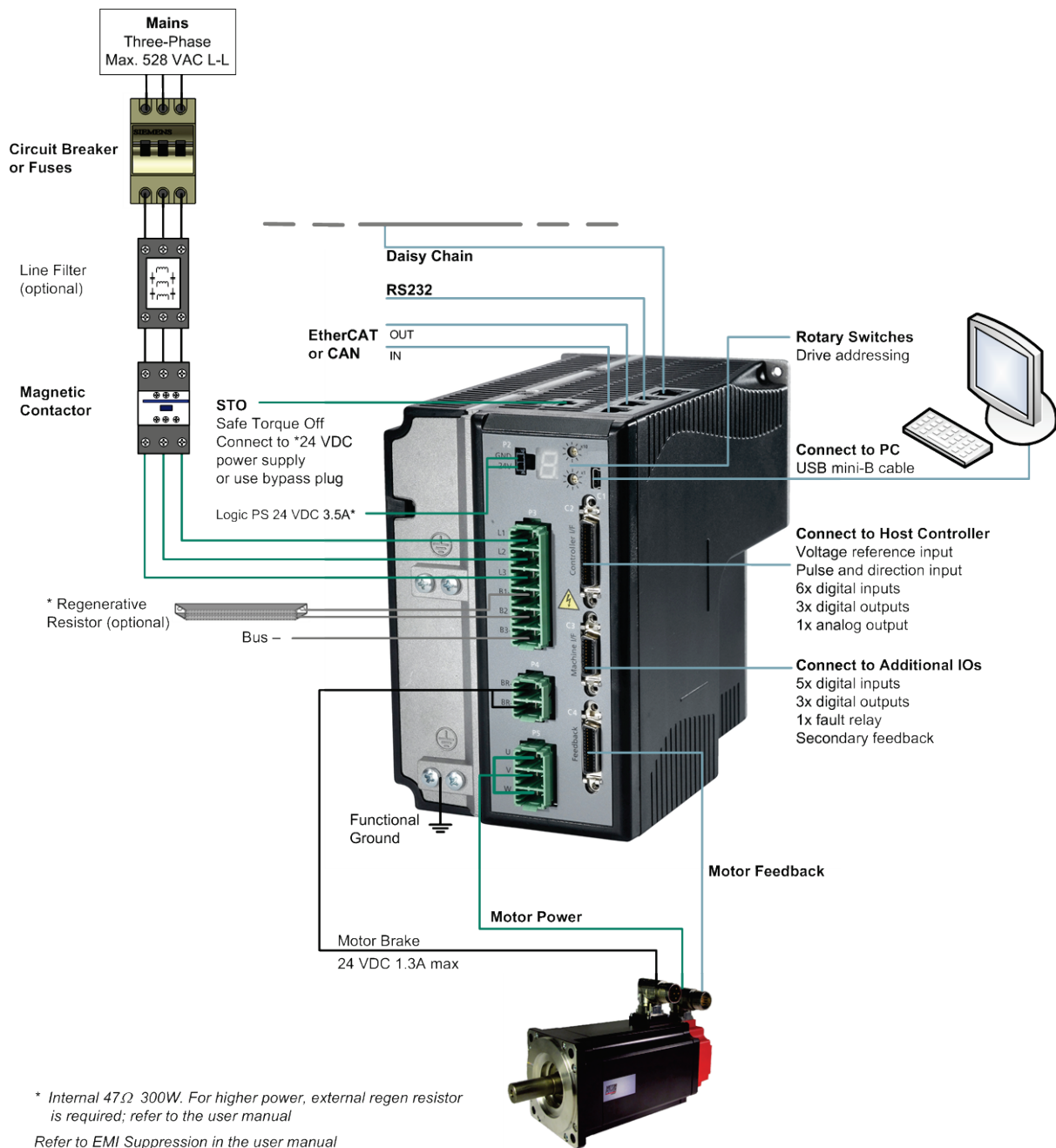

FLEXI PRO-003/FLEXI PRO-006 – Servo System Wiring – 400/480 VAC, 3-Phase

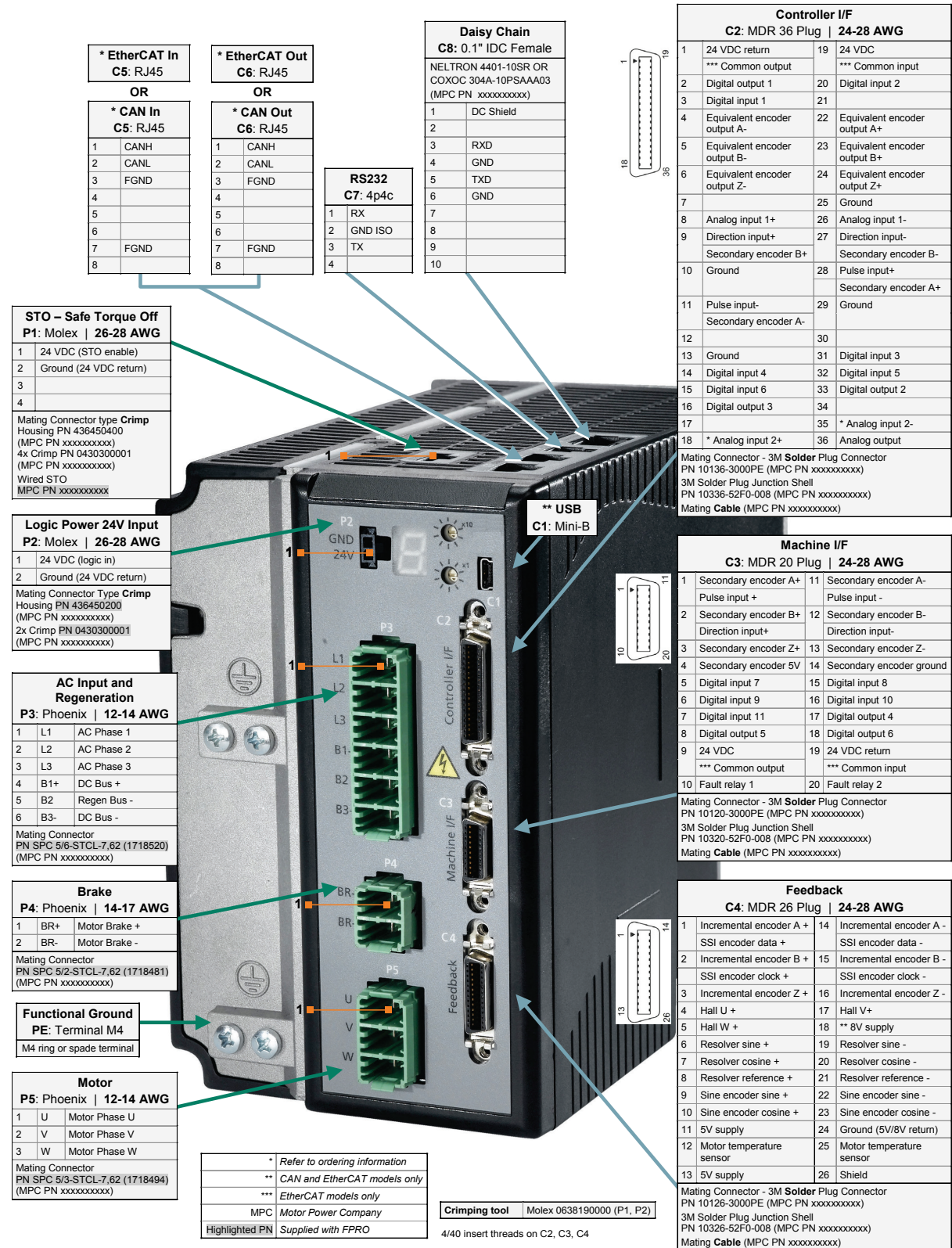

FLEXI PRO-003/FLEXI PRO-006 – Pin Assignments – 400/480 VAC

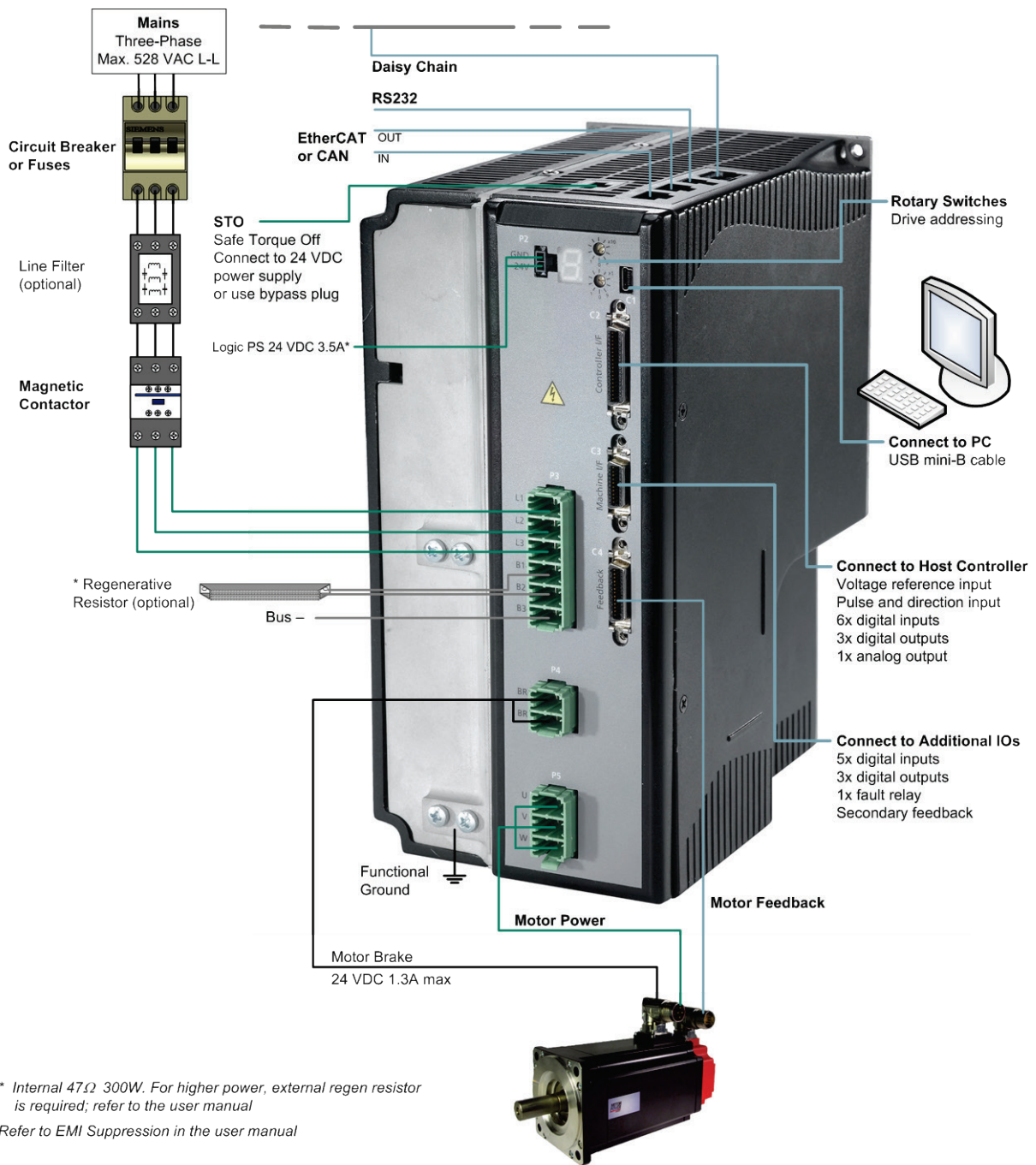

FLEXI PRO-0012 – Servo System Wiring – 400/480 VAC, 3-Phase

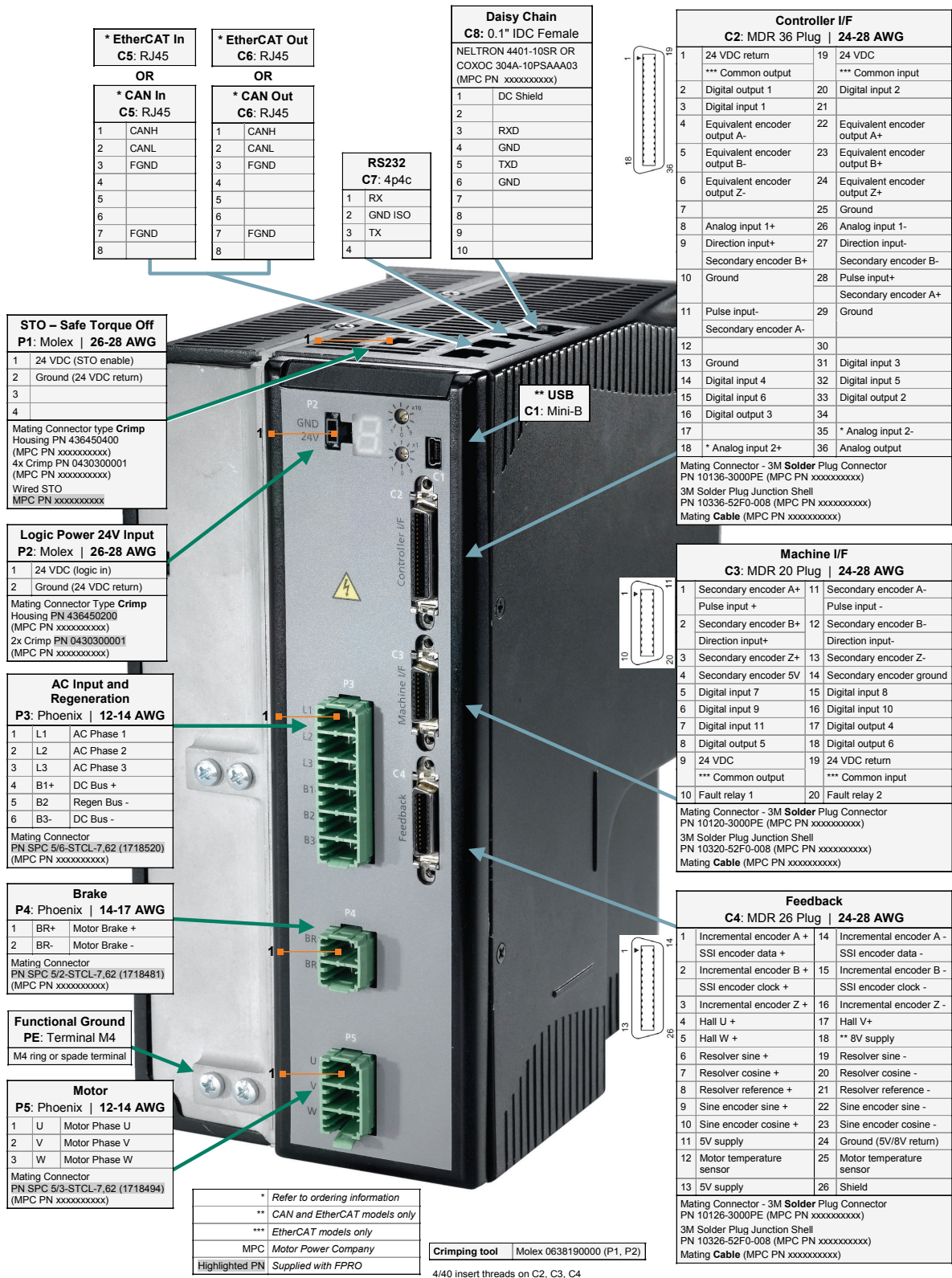

FLEXI PRO-012 – Pin Assignments – 400/480 VAC

2 Control Board

Overview

The control board has the same interfaces on all FLEXI PRO models:

- USB Communication – C1 (Exception: AP models do not have a USB port.)
- Controller I/Os – C2
- Machine I/Os – C3
- Motor Feedback – C4
- Fieldbus Devices (optional) – C5 and C6
- RS232 Communication – C7
- Daisy Chain – C8
- Drive Address Rotary Switches

Controller I/Os – C2

Controller I/Os are connected through interface C2 on all FLEXI PRO models.

Wire the digital and analog inputs and outputs according to the requirements of your application.

Unused pins must remain unwired.

To preserve isolation of the digital I/Os, connect a 24 VDC source to pin 19. Connect the return of the 24 VDC supply to pin 1, which functions as the ground path for the outputs.

Note: AP/AF Models: The 24 VDC supply and return can be connected on either the Controller interface (C2) or the Machine interface (C3), but it is not necessary to connect it on both.

Notes: EC/PN Models:

- Common output on the Controller interface (C2) and the Machine interface (C3) are connected internally.
- Common input on the Controller interface (C2) and the Machine interface (C3) are connected internally.
- User can connect outputs as source or sink.
- User can connect inputs as source or sink.
- Refer to the Controller Interface Wiring schematic diagram for EC/PN Models below, and the FLEXI PRO System Wiring - Pin Assignments diagram for EC/PN Models at the end of this manual.

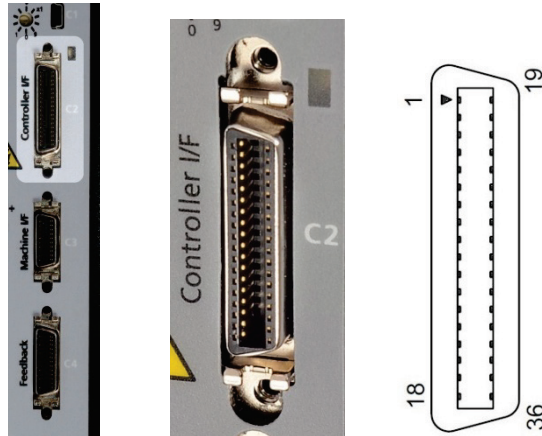

Controller I/O Interface

Pin	Function	Description	Pin	Function	Description
1	24 VDC return	AP/AF Models: Return of the user-supplied 24 VDC	19	24 VDC	AP/AF Models: User supplied 24V, for I/O biasing
	Common output	EC/PN Models		Common input	EC/PN Models
2	Digital output 1	Opto-isolated programmable digital output. Read using OUT1	20	Digital input 2	Opto-isolated programmable digital input. Read using IN2
3	Digital input 1	Opto-isolated programmable digital input. Read using IN1	21		
4	Equivalent encoder output A-	Low side of the equivalent encoder output signal A (RS422)	22	Equivalent encoder output A+	High side of the equivalent encoder output signal A (RS422)
5	Equivalent encoder output B-	Low side of the equivalent encoder output signal B (RS422)	23	Equivalent encoder output B+	High side of the equivalent encoder output signal B (RS422)
6	Equivalent encoder output Z-	Low side of the equivalent encoder output index (RS422)	24	Equivalent encoder output Z+	High side of the equivalent encoder output index (RS422)
7			25	Ground	Digital ground
8	Analog input 1+	High side of the differential analog command input (± 10 VDC)	26	Analog input 1-	Low side of the differential analog command input (± 10 VDC)
9	Direction input+	High side of the direction signal (RS422), or High side of the down count signal	27	Direction input-	Low side of the direction signal (RS422), or Low side of the down count signal
	Secondary encoder B+	High side of the Secondary encoder input signal B (RS422)		Secondary encoder B-	Low side of the secondary encoder input signal B (RS422)

Pin	Function	Description	Pin	Function	Description
10	Ground	Digital ground	28	Pulse input+	High side of the pulse signal (RS422), or High side of the master encoder signal A, or High side of the up count signal
				Secondary encoder A+	High side of the secondary encoder input signal A (RS422)
11	Pulse input-	Low side of the pulse signal (RS422), or Low side of the master encoder signal A, or Low side of the up count signal	29	Ground	Digital ground
	Secondary encoder A-	Low side of the secondary encoder input signal A (RS422)			
12			30		
13	Ground	Digital ground	31	Digital input 3	Opto-isolated programmable digital input. Read using IN3
14	Digital input 4	Opto-isolated programmable digital input. Read using IN4	32	Digital input 5	Fast opto-isolated programmable digital input. Read using IN5
15	Digital input 6	Fast opto-isolated programmable digital input. Read using IN6	33	Digital output 2	Opto-isolated programmable digital output. Read using OUT2
16	Digital output 3	Fast opto-isolated programmable digital output. Read using OUT3	34		
17			35*	Analog input 2-	Low side of the second differential analog input (± 10 VDC)
18*	Analog input 2+	High side of the second differential analog input (± 10 VDC)	36	Analog output	Analog output, referenced to digital ground (0-10 VDC)

* Optional, see ordering information

Controller Interface Wiring

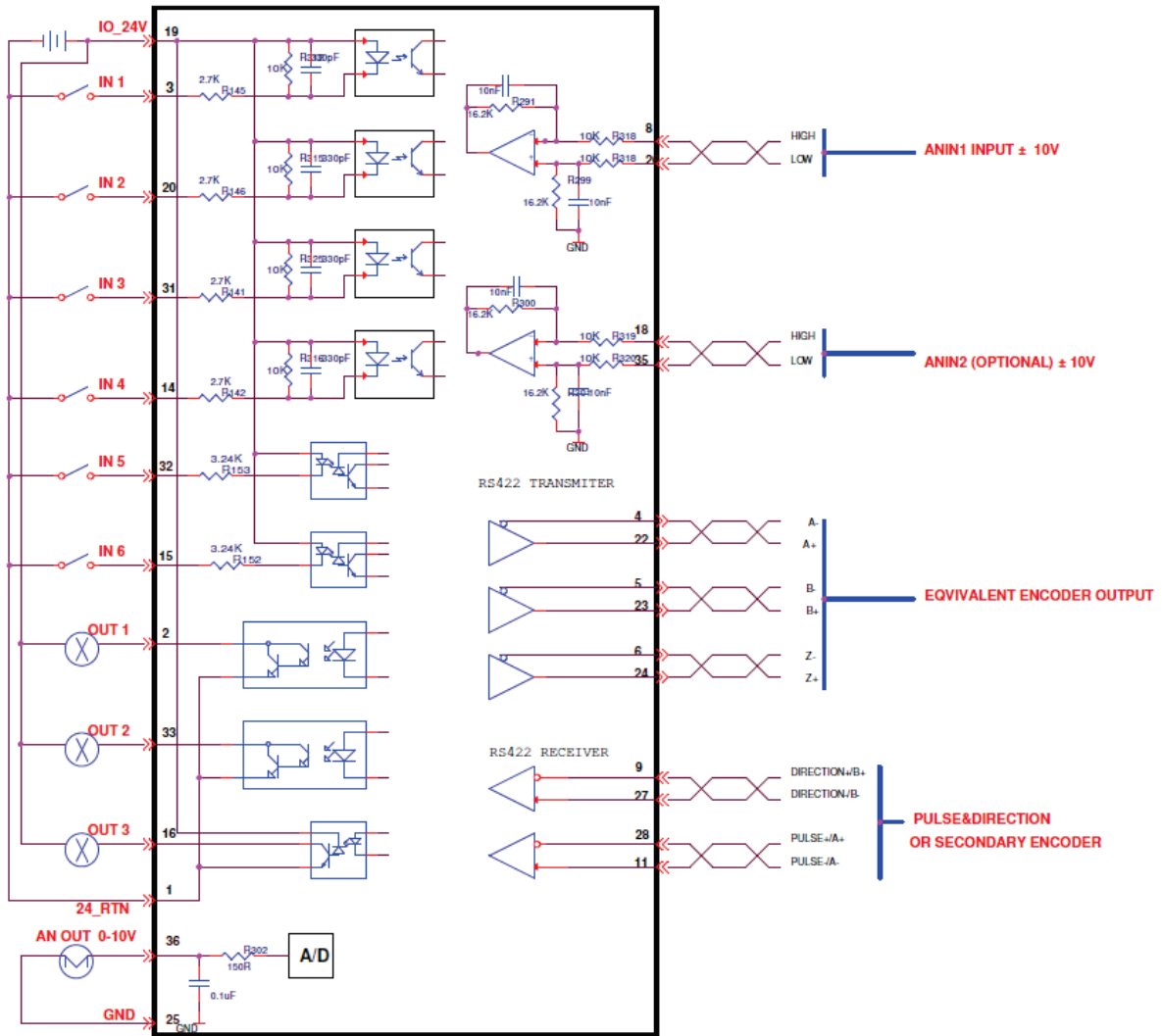

Controller Interface Wiring – AP/AF Models

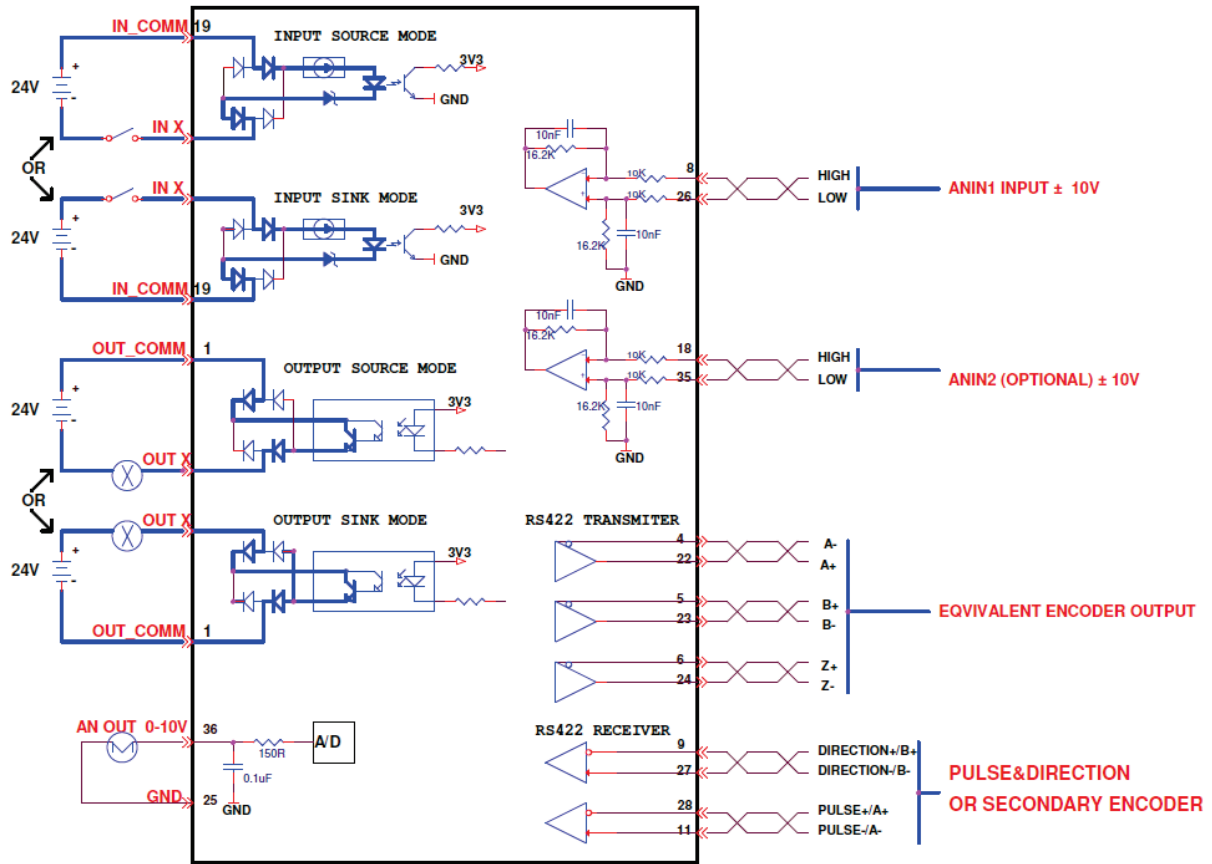

Controller Interface Wiring – EC/PN Models

Machine I/Os – C3

Machine I/Os are connected through interface C3 on all FLEXI PRO models.

Wire the machine inputs and outputs according to the requirements of your application.

Unused pins must remain unwired.

To preserve isolation of the digital I/Os, connect a 24 VDC source to pin 9. Connect the return of the 24 VDC supply to pin 19, which functions as the ground path for the outputs.

Note: AP/AF Models: The 24 VDC supply and return can be connected on either the Controller interface (C2) or the Machine interface (C3), but it is not necessary to connect it to both.

Notes: EC/PN Models:

- Common output on the Controller interface (C2) and the Machine interface (C3) are connected internally.
- Common input on the Controller interface (C2) and the Machine interface (C3) are connected internally.
- User can connect outputs as source or sink.
- User can connect inputs as source or sink.
- Refer to the Machine Interface Wiring schematic diagram for EC/PN Models below, and the FLEXI PRO System Wiring - Pin Assignments diagram for EC/PN Models at the end of this manual.

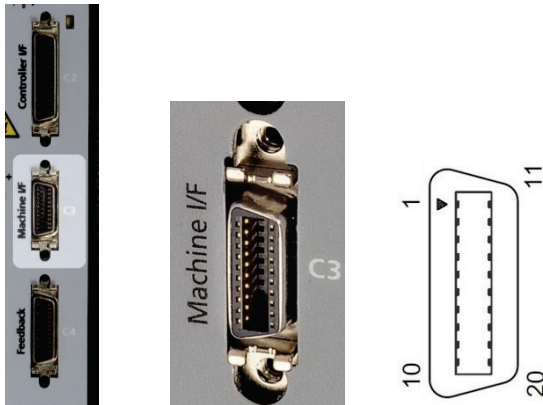

Machine I/O Interface

Pin	Function	Description	Pin	Function	Description
1	Secondary encoder A+	High side of the secondary encoder input signal A (RS422)	11	Secondary encoder A-	Low side of the secondary encoder input signal A (RS422)
	Pulse input+	High side of the pulse signal		Pulse input-	Low side of the pulse signal
2	Secondary encoder B+	High side of the Secondary encoder input signal B (RS422)	12	Secondary encoder B-	Low side of the secondary encoder input signal B (RS422)
	Direction input+	High side of the direction signal		Direction input-	Low side of the direction signal
3	Secondary encoder Z+	High side of the secondary encoder input index (RS422)	13	Secondary encoder Z-	Low side of the secondary encoder input index (RS422)
4	Secondary encoder 5V	5 VDC supply for the secondary encoder	14	Secondary encoder ground	Ground of the 5 VDC supply for the secondary encoder.
5	Digital input 7	Opto-isolated programmable digital input. Read using IN7	15	Digital input 8	Opto-isolated programmable digital input. Read using IN8
6	Digital input 9	Opto-isolated programmable digital input. Read using IN9	16	Digital input 10	Opto-isolated programmable digital input. Read using IN10
7	Digital input 11	Fast opto-isolated programmable digital input. Read using IN11	17	Digital output 4	Opto-isolated programmable digital output. Read using OUT4
8	Digital output 5	Opto-isolated programmable digital output. Read using OUT5	18	Digital output 6	Fast opto-isolated programmable digital output. Read using OUT6
9	24 VDC	AP/AF Models: User supplied 24V, for I/O biasing	19	24 VDC return	AP/AF Models: Return of the user-supplied 24 VDC
	Common output	EC/PN Models		Common input	EC/PN Models
10	Fault relay 1	Terminal 1 of the dry contact fault relay	20	Fault relay 2	Terminal 2 of the dry contact fault relay

Machine Interface Wiring

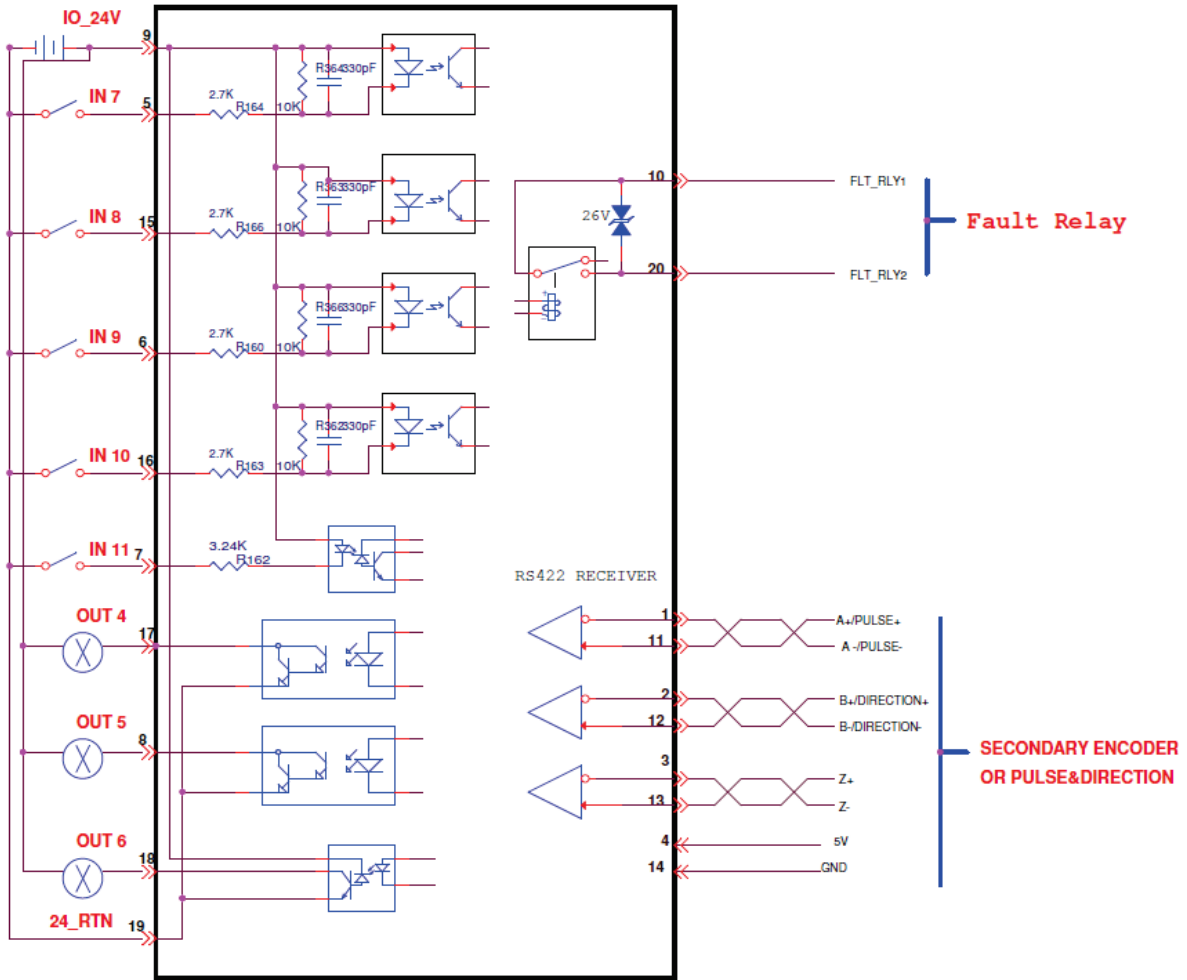

Machine Interface Wiring – AP/AF Models

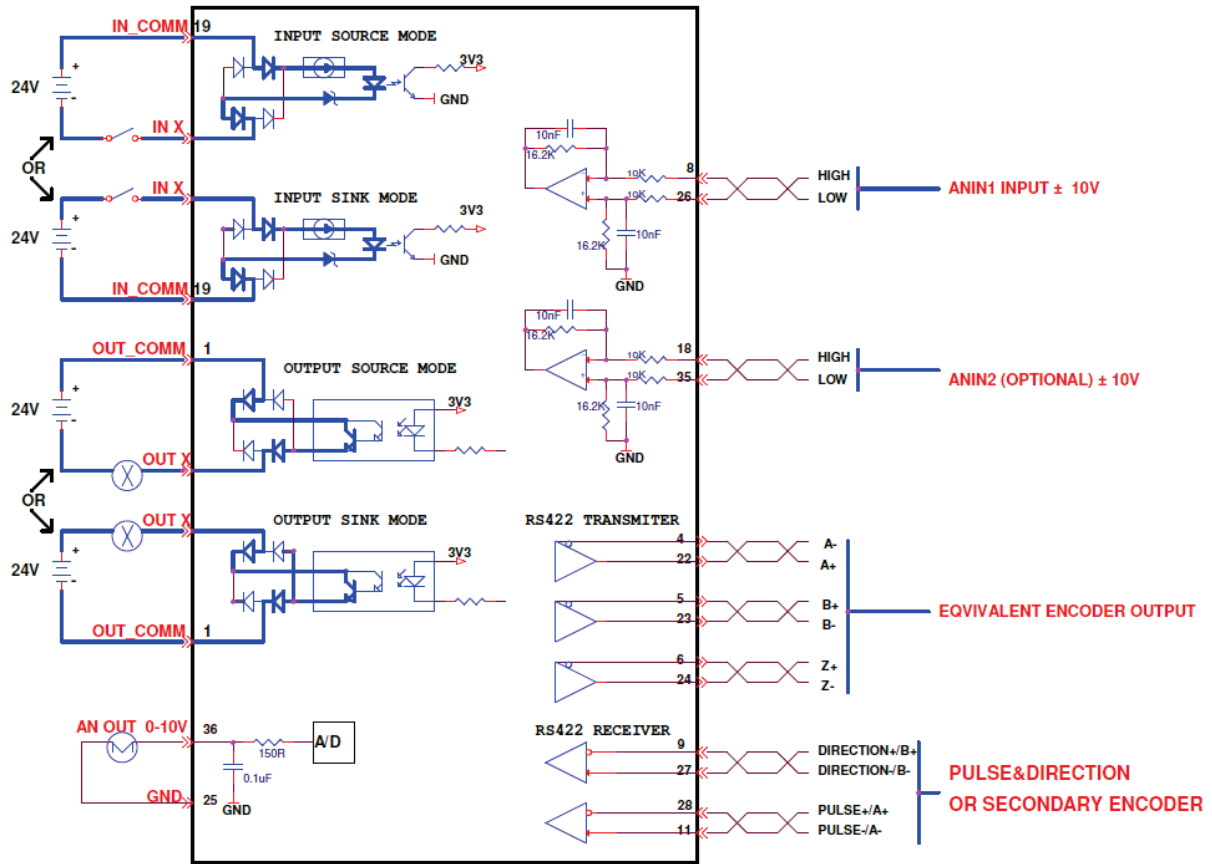

Machine Interface Wiring – EC/PN Models

Motor Feedback – C4

Motor Feedback uses interface C4 on all FLEXI PRO models.

Wire the motor feedback interface according to the type of feedback device to be used in your application. Refer to the guidelines following the pinout table below.

Pins 1, 2, 14 and 15 have dual functionality.

Pin 25 for the motor temperature sensor is connected internally in the drive to FLEXI PRO ground.

Unused pins must remain unwired.

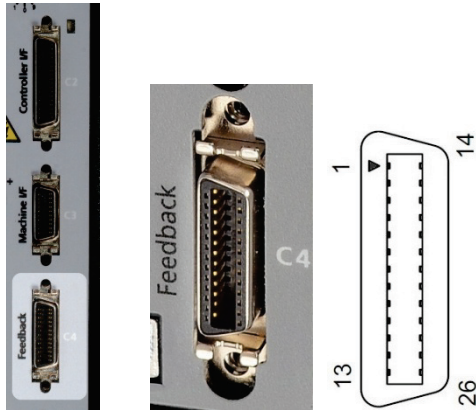

Motor Feedback Interface

Pin	Function	Pin	Function
1	Incremental encoder A +	14	Incremental encoder A -
	SSI encoder data +		SSI encoder data -
2	Incremental encoder B +	15	Incremental encoder B -
	SSI encoder clock +		SSI encoder clock -
3	Incremental encoder Z +	16	Incremental encoder Z -
4	Hall U +	17	Hall V+
5	Hall W +	18	AF/EC/PN Models: 8V supply
6	Resolver sine +	19	Resolver sine -
7	Resolver cosine +	20	Resolver cosine -
8	Resolver reference +	21	Resolver reference -
9	Sine encoder sine +	22	Sine encoder sine -
10	Sine encoder cosine +	23	Sine encoder cosine -
11	5V supply	24	Ground (5V/8V return)
12	Motor temperature sensor	25	Motor temperature sensor
13	5V supply	26	Shield

Feedback Wiring Guidelines

The following tables present the most common feedback variations. If your motor feedback does not match any one of the following, contact technical support.

The tables present the wiring pin layout. Use the User Motor Pin# column in these tables to record the pin numbers of your specific motor for future reference.

Notes for Wiring Tables

- A If the motor does not support a temperature sensor, do not connect pins 12 and 25.
- B If the motor has an additional temperature sensor, connect pins 12 and 25.
- C Halls are single-ended signals. To use differential Hall signals, refer to the relevant wiring tables.
- D Incremental encoders with Hall sensors and index pulse.
A, B and Z signals use the same wiring as Hall sensors U, V, and W.
On power up, feedback briefly sends Hall readings, and then continuously sends the A, B and Z signals.
- E On every power up, the phase find procedure must be executed.
- F Encoder backup battery is external to the FLEXI PRO drive.
Voltage must be more than 3.6 VDC. The recommended battery is lithium (ER3V: 3.6V, 1000mAh), manufactured by Toshiba Corp.
- G A serial digital data encoder. A single-turn absolute encoder transmits absolute position data at 17-bit per revolution (131,072 count per rev).
- H A serial digital data encoder. This is a full absolute encoder with 17-bit per revolution resolution and xx-bit multi-turn counting.
When the battery is disconnected, it functions as a full absolute encoder that transmits absolute position data at 17-bit per revolution.
- I To use differential Halls with A quad B and index, connect the Halls to the Machine interface as follows:
Hall U+ to Machine I/F pin 1, Hall U- to Machine I/F pin 11.
Hall V+ to Machine I/F pin 2, Hall V- to Machine I/F pin 12.
Hall W+ to Machine I/F pin 3, Hall W- to Machine I/F pin 13.
Connect the encoder A, B, I, and power supply to the Motor Feedback connector.

Use the FLEXI SUITE Motor Setup procedure and the Feedback screens to define motor feedback type, resolution, and other parameters.

Feedback Wiring – Resolver

Pin #	Twisted Pair	User Motor Pin#	Signal Description
6	Twisted Pair		Resolver Sine +
19			Resolver Sine -
7	Twisted Pair		Resolver Cosine +
20			Resolver Cosine -
8	Twisted Pair		Resolver Reference +
21			Resolver Reference -
12	Twisted Pair		Motor Temperature Sensor
25			Motor Temperature Sensor
24	Ground		Optional: Internal shield of each twisted pair (sine, cosine, reference)
26			Cable Shield

Note: A

Feedback Wiring - Incremental Encoder A Quad B, Index Pulse and Halls

Pin #	Twisted Pair	User Motor Pin#	Signal Description
1	Twisted Pair		Incremental Encoder A+
14			Incremental Encoder A-
2	Twisted Pair		Incremental Encoder B+
15			Incremental Encoder B-
3	Twisted Pair		Incremental Encoder Z+
16			Incremental Encoder Z-
4			Hall U
17			Hall V
5			Hall W
12	Twisted Pair		Motor Temperature Sensor
25			Motor Temperature Sensor
11			+5 VDC
24			0 VDC
26			Shield

Notes: A, C

Feedback Wiring – Single-Ended Halls Only

Pin #	Twisted Pair	User Motor Pin#	Signal Description
4			Hall U
17			Hall V
5			Hall W
11			+5 VDC
24			0 VDC
26			Shield

Notes: A, C

Feedback Wiring - Incremental Encoder A Quad B, Index Pulse and Differential Halls

Pin #	Twisted Pair	User Motor Pin#	Signal Description
1	Twisted Pair		Incremental Encoder A+
14			Incremental Encoder A-
2	Twisted Pair		Incremental Encoder B+
15			Incremental Encoder B-
9			Hall U+
22			Hall U-
10			Hall V+
23			Hall V-
3			Hall W+
16			Hall W-
12	Twisted Pair		Motor Temperature Sensor
25			Motor Temperature Sensor
11			+5 VDC
24			0 VDC
26			Shield

Notes: A, I

Feedback Wiring –Differential Halls Only

Pin #	Twisted Pair	User Motor Pin#	Signal Description
9			Hall U+
22			Hall U-
10			Hall V+
23			Hall V-
3			Hall W+
16			Hall W-
12	Twisted Pair		Motor Temperature Sensor
25			Motor Temperature Sensor
11			+5 VDC
24			0 VDC
26			Shield

Notes: A

Feedback Wiring - Incremental Tamagawa

Pin #	Twisted Pair	User Motor Pin#	Signal Description
1	Twisted Pair		Incremental Encoder A+ / Hall U+
14			Incremental Encoder A- / Hall U-
2	Twisted Pair		Incremental Encoder B+ / Hall V+
15			Incremental Encoder B- / Hall V-
3	Twisted Pair		Incremental Encoder Z+ / Hall W+
16			Incremental Encoder Z- / Hall W-
11			+5 VDC
24			0 VDC
26			Shield

Notes: B, D

Feedback Wiring - Sine Encoder

Pin #	Twisted Pair	User Motor Pin#	Signal Description
9	Twisted Pair		Sine Encoder Sine+
22			Sine Encoder Sine-
10	Twisted Pair		Sine Encoder Cosine+
23			Sine Encoder Cosine-
11			+5VDC
24			0VDC
26			Shield

Notes: B, E

Feedback Wiring - Sine Encoder with Halls

Pin #	Twisted Pair	User Motor Pin#	Signal Description
9	Twisted Pair		Sine Encoder Sine+
22			Sine Encoder Sine-
10	Twisted Pair		Sine Encoder Cosine+
23			Sine Encoder Cosine-
4			Hall U
17			Hall V
5			Hall W
11			+5 VDC
24			0 VDC
26			Shield

Note: B

Feedback Wiring – Sine Encoder with Index

Pin #	Twisted Pair	User Motor Pin#	Signal Description
9	Twisted Pair		Sine Encoder Sine+
22			Sine Encoder Sine-
10	Twisted Pair		Sine Encoder Cosine+
23			Sine Encoder Cosine-
3	Twisted Pair		Sine Encoder Z+
16			Sine Encoder Z-
11			+5 VDC
24			0 VDC
26			Shield

Note: B

Feedback Wiring – Sine Encoder with Index and Halls

Pin #	Twisted Pair	User Motor Pin#	Signal Description
9	Twisted Pair		Sine Encoder Sine+
22			Sine Encoder Sine-
10	Twisted Pair		Sine Encoder Cosine+
23			Sine Encoder Cosine-
3	Twisted Pair		Sine Encoder Z+
16			Sine Encoder Z-
4			Hall U
17			Hall V
5			Hall W
11			+5 VDC
24			0 VDC
26			Shield

Note: B

Feedback Wiring – Sick 5V (Hiperface Protocol and Sine Signal)

Pin #	Twisted Pair	User Motor Pin#	Signal Description
1	Twisted Pair		SSI Data +
14			SSI Data -
9	Twisted Pair		Sine Encoder Sine+
22			Sine Encoder Sine-
10	Twisted Pair		Sine Encoder Cosine+
23			Sine Encoder Cosine-
11			+5 VDC
24			0 VDC
26			Shield

Note: B

Feedback Wiring - Sick 8V (Hiperface Protocol and Sine Signal)

Pin #	Twisted Pair	User Motor Pin#	Signal Description
1	Twisted Pair		SSI Data +
14			SSI Data -
9	Twisted Pair		Sine Encoder Sine+
22			Sine Encoder Sine-
10	Twisted Pair		Sine Encoder Cosine+
23			Sine Encoder Cosine-
18			+8 VDC
24			0 VDC
26			Shield

Note: B

Feedback Wiring – Heidenhain (EnDat 2.x Communication Only)

Pin #	Twisted Pair	User Motor Pin#	Signal Description
1	Twisted Pair		SSI Data +
14			SSI Data -
2	Twisted Pair		SSI Clock +
15			SSI Clock -
11			+5 VDC
24			0 VDC
26			Shield

Note: B

Feedback Wiring – Heidenhain (EnDat 2.x with Sine/Cosine)

Pin #	Twisted Pair	User Motor Pin#	Signal Description
1	Twisted Pair		SSI Data +
14			SSI Data -
2	Twisted Pair		SSI Clock +
15			SSI Clock -
9	Twisted Pair		Sine Encoder Sine+
22			Sine Encoder Sine-
10	Twisted Pair		Sine Encoder Cosine+
23			Sine Encoder Cosine-
11			+5 VDC
24			0 VDC
26			Shield

Note: B

Feedback Wiring - Nikon 17-bit Single Turn

Pin #	Twisted Pair	User Motor Pin#	Signal Description
1	Twisted Pair		Serial Data +
14			Serial Data -
11			+5 VDC
24			0 VDC
26			Shield

Notes: B

Feedback Wiring - Nikon 17-bit Multi Turn

Pin #	Twisted Pair	User Motor Pin#	Signal Description
1	Twisted Pair		Serial Data +
14			Serial Data -
11			+5 VDC
24			0 VDC
26			Shield
			Battery Voltage
			Battery Ground

Notes: B, F

Feedback Wiring - Incremental Tamagawa 17-bit Single Turn

Pin #	Twisted Pair	User Motor Pin#	Signal Description
1	Twisted Pair		Serial Data +
14			Serial Data -
11			+5 VDC
24			0 VDC
26			Shield

Notes: B, G

Feedback Wiring - Tamagawa 17-bit Multi Turn

Pin #	Twisted Pair	User Motor Pin#	Signal Description
1	Twisted Pair		Serial Data +
14			Serial Data -
11			+5 VDC
24			0 VDC
26			Shield
			Battery Voltage
			Battery Ground

Notes: B, F, H

Fieldbus Devices – C5 and C6

All FLEXI PRO models have the same RJ45 connectors.

CANopen Communication

1. Be sure the required EDS file is installed in the controller. You can download the file from the Motor Power Company website or contact Technical Support

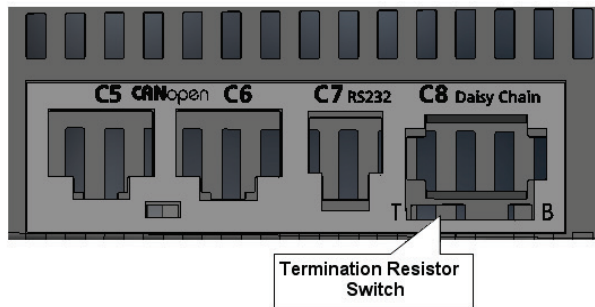

2. Note the Termination Resistor switch located on the top of the drive next to the daisy chain connector (C8).

Use a small slotted screwdriver or similar tool to set the switch position:

- Towards T (default): 120Ω termination resistor not in use.
 - Away from T: Used when the drive is the last drive in a chain. The drive provides the 120Ω termination resistor between CAN high and CAN low.
3. Using any RJ45 cables:
 - Connect the host to the drive on interface C5.
 - Connect the next node to interface C6.

EtherCAT Communication

1. Be sure you have installed the required XML file. You can download the file from the Motor Power Company website or contact Technical Support.

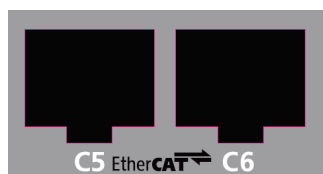

2. Using any RJ45 cables:
 - Connect the host to the drive on interface C5.
 - Connect the next node to interface C6.

Host Computer – C1, C7

On all FLEXI PRO models the drive can be connected to the host computer through either one of the following interfaces:

- USB port. The interface is labeled C1 on all FLEXI PRO models (Exception: AP models do not have a USB port.) Use a USB 2.0 A to Mini-B cable.



- RS232 port. The interface is labeled C7 on all FLEXI PRO models. Use a 4p4c plug.

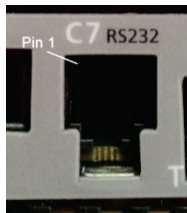

RS232 Interface – 4P4C

Pin	Pin Label	Function
1	RX	Receive
2	GND ISO	Ground
3	TX	Transmit
4		Unused

Daisy Chain – C8

The FLEXI PRO can be addressed and controlled on a daisy-chained RS-232 line.

In a daisy-chain RS-232 configuration, all drives must be daisy-chained through the C8 connector. Each drive must have a unique address to enable its identification on the network.

A daisy-chained drive can be assigned an address from 1 to 99 by setting the rotary switches on the drive. When configuring a daisy-chain, address 0 cannot be used.



Daisy Chain Interface

Pin	Function
1	DC Shield
2	Unused
3	RXD
4	GND
5	TXD
6	GND
7-10	Unused

Drive Address Switches

On all FLEXI PRO models, two rotary switches are used to set the drive address for both CAN and serial communication. Use a small slotted screwdriver or similar tool to set the switches.

Each switch has 10 positions:

- The upper switch positions are set as tens: 10, 20, 30 ... 90
- The lower switch positions are set as ones: 0, 1, 2 ... 9

Each drive on the network must have a unique address.

Note: If two or more drives are connected to the network, address 0 cannot be used. A single drive may have the address 0.



3 Power Board 120/240 VAC

Overview

On most FLEXI PRO 120/240 VAC models, the power board has the following interfaces:

- STO – P1
- Motor – P2 (P4 on FLEXI PRO-020/024)
- Regeneration Resistor – P3 (P5 on FLEXI PRO-020/024)
- AC Input Voltage – P3, P4 (P2, P3 on FLEXI PRO-020/024)



Make sure the main voltage rating matches the drive specification. Applying incorrect voltage may cause drive failure.

Do not apply power until all hardware connections are complete.

Safe Torque Off (STO) – P1

STO uses interface P1 on all FLEXI PRO 120/240 VAC models.

Safe torque off (STO) is a safety function that prevents the drive from delivering power to the motor, which can generate torque.

STO Enable and STO Return must be connected to enable FLEXI PRO operation. The STO Enable signal voltage must be 24 VDC.

Note: If the application does not require STO control, jumper pin 4 to pin 1, and pin 3 to pin 2, to bypass the STO.

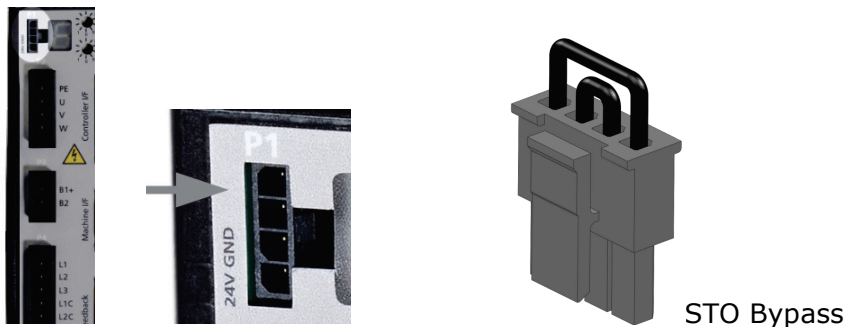

STO Interface

Pin	Pin Label	Function
1	24V	STO Enable
2	GND	STO Return
3		24V Return, provided by the drive for use with emergency stop circuit
4		24V Supply, provided by the drive for use with emergency stop circuit

Motor – P2

Motor uses interface P2 on all FLEXI PRO 120/240 models.

Exception: Motor uses P4 on FLEXI PRO-020/024.

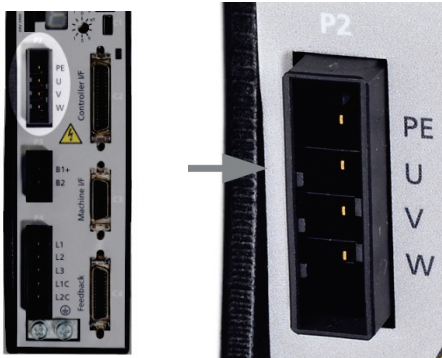

Motor Interface

Pin	Pin Label	Function
1	PE	Protective ground (motor housing)
2	U	Motor Phase U
3	V	Motor Phase V
4	W	Motor Phase W

Regeneration Resistor – P3

Regen uses interface P3 on all FLEXI PRO 120/240 VAC models.

Exception: Regen uses P5 FLEXI PRO-020/024.

Note: On models FLEXI PRO-1D5 and FLEXI PRO-003, Regen and AC Input Voltage are combined on one connector.

If the application requires a regeneration (regen) resistor, connect the regen resistor between terminals B1+ and B2.

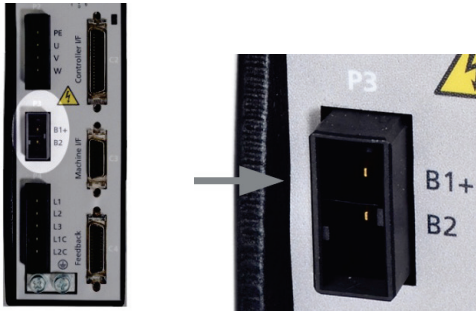

Regen Interface

Pin	Pin Label	Function
1	B1+	DC bus +
2	B2	Regen bus -

Regen Interface on FLEXI PRO -020/024

Pin	Pin Label	Function
1	B2	Regen bus -
2	B1+	DC bus +

AC Input – P3, P4, P5

The AC Input interfaces and connectors vary among FLEXI PRO 120/240 VAC models.

- FLEXI PRO-1D5 and FLEXI PRO-003: One connector for bus power and logic power uses interface P3.
- FLEXI PRO-4D5 and FLEXI PRO-006: One connector for bus power and logic power uses interface P4.
- FLEXI PRO-008, CHDH-010 and FLEXI PRO-013: Two connectors – a connector for bus power uses interface P4, and another connector for logic power uses interface P5.
- FLEXI PRO -020/024: Two connectors – a connector for bus power uses interface P3, and another connector for logic power uses interface P2.

Make the following connections:

1. Connect the AC input voltage ground wire to the PE terminal, located on the FLEXI PRO front panel. Use an M4 ring or spade terminal.



2. Connect L1, L2 and L3 (for bus power):
 - If the main voltage is from a single-phase source, connect line and neutral to L1 and L2.
 - If the main voltage is from a three-phase source, connect the phases to L1, L2 and L3.
3. Connect L1C and L2C (for logic power):
 - If the main voltage is from a single-phase source, connect line and neutral to L1C and L2C.
 - If the main voltage is from a three-phase source, connect any two phases to L1C and L2C.

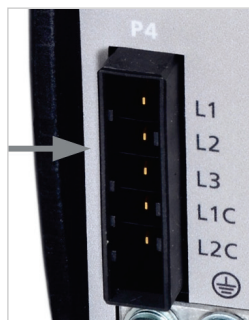

AC Input Voltage Interface

Note: On models FLEXI PRO-1D5 and FLEXI PRO-003, Regen and AC Input Voltage are combined on one connector.

FLEXI PRO-1D5 FLEXI PRO-003	Pin	Pin Label	Function
P3	3	L1	AC Phase 1
	4	L2	AC Phase 2
	5	L1C	Logic AC Phase 1
	6	LC2	Logic AC Neutral
FLEXI PRO-4D5 FLEXI PRO-006	Pin	Pin Label	Function
P4	1	L1	AC Phase 1
	2	L2	AC Phase 2
	3	L3	AC Phase 3
	4	L1C	Logic AC Phase 1
	5	LC2	Logic AC Neutral
FLEXI PRO-008 FLEXI PRO-010 FLEXI PRO-013	Pin	Pin Label	Function
P4	1	L1	AC Phase 1
	2	L2	AC Phase 2
	3	L3	AC Phase 3
P5	1	L1C	Logic AC Phase 1
	2	LC2	Logic AC Neutral
FLEXI PRO-020 FLEXI PRO-024	Pin	Pin Label	Function
P3	1	L1	AC Phase 1
	2	L2	AC Phase 2
	3	L3	AC Phase 3
P2	1	L1C	Logic AC Phase 1
	2	LC2	Logic AC Neutral

4 Power Board 400/480 VAC

Overview

On all FLEXI PRO 400/480 VAC models, the power board has the following interfaces:

- STO – P1
- Logic Power 24 VDC – P2
- AC Input and Regeneration – P3
- Brake – P4
- Motor – P5



Make sure the main voltage rating matches the drive specification. Applying incorrect voltage may cause drive failure.

Do not apply power until all hardware connections are complete.

Safe Torque Off (STO) – P1

STO uses interface P1 on all FLEXI PRO 400/480 VAC models:

Safe torque off (STO) is a safety function that prevents the drive from delivering power to the motor, which can generate torque.

STO Enable and STO Return must be connected to enable FLEXI PRO operation. The STO Enable signal voltage must be 24 VDC.

Note: If the application does not require STO control, jumper pin 4 to pin 1, and pin 3 to pin 2, to bypass the STO.

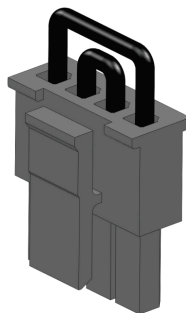

STO Bypass

STO Interface

Pin	Pin Label	Function
1	24V	STO Enable
2	GND	24 VDC Return
3		
4		

Logic Power 24V Input – P2

Logic Power 24V uses interface P2 on all FLEXI PRO 400/480 VAC models.

This interface is used to connect an external power supply (24V 3.15A max.) that provides the logic voltage to the control board and to the motor brake circuit.



Logic Power 24V Interface

Pin	Pin Label	Function
1	24V	Logic In
2	GND	24 VDC Return

AC Input and Regeneration Resistor – P3

AC Input and Regen Resistor use interface P3 on all FLEXI PRO 400/480 VAC models.

1. Connect the AC input voltage ground wire to the PE terminal, located on the FLEXI PRO front panel. Use an M4 ring or spade terminal.



2. Connect L1, L2 and L3 for the AC power input.
3. If the application requires a regeneration (regen) resistor, connect the regen resistor between terminals B1+ and B2.

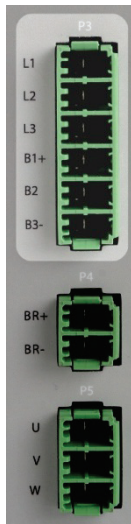

AC Input and Regeneration Resistor Interface

Pin	Pin Label	Function
1	L1	AC Phase 1
2	L2	AC Phase 2
3	L3	AC Phase 3
4	B1+	DC Bus +
5	B2	Regen Bus
6	B3-	DC Bus -

Brake – P4

Brake uses interface P4 on all FLEXI PRO 400/480 VAC models.
This is the power output for the electric motor brake system.

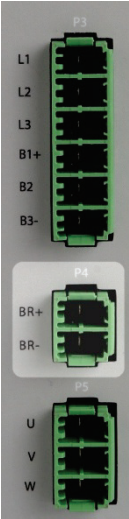

Brake Interface

Pin	Pin Label	Function
1	BR+	Motor Brake +
2	BR-	Motor Brake -

Motor – P5

Motor uses interface P5 on all 400/480 VAC models:

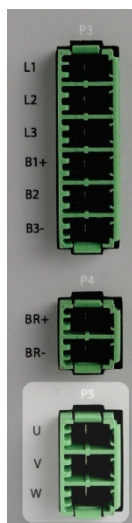

Motor Interface

Pin	Pin Label	Function
1	U	Motor Phase U
2	V	Motor Phase V
3	W	Motor Phase W

5 Software

FLEXI SUITE Installation

Use FLEXI SUITE software to configure the drive for your application.

1. Install FLEXI SUITE on the host computer.
2. When installation is complete, start FLEXI SUITE.

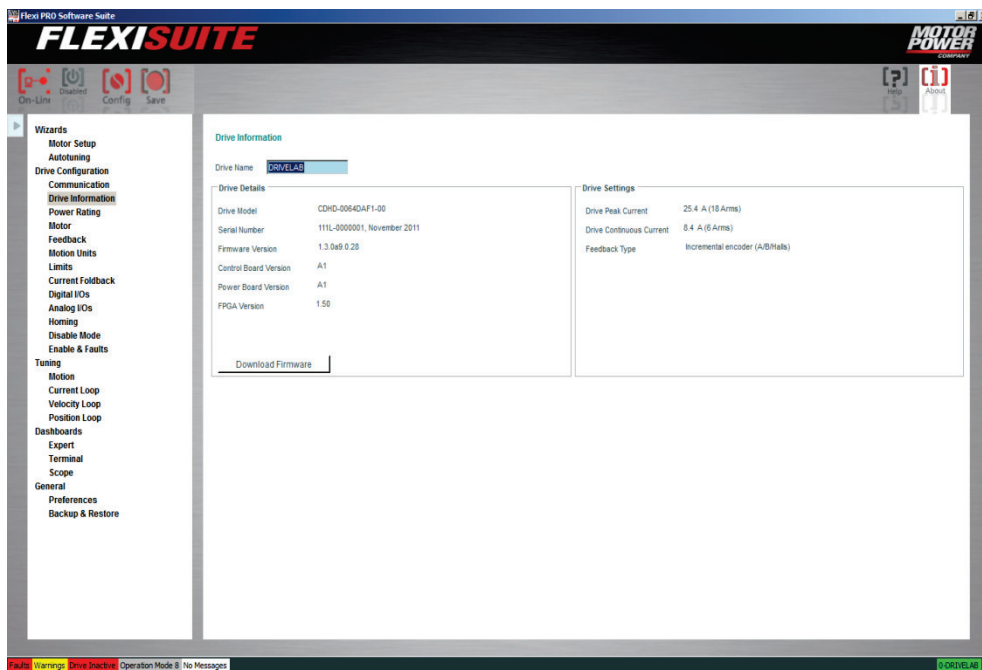

Power Up

1. After completing the hardware connections, turn on power to the drive.
2. The first time the drive is connected to the host computer on the USB port, Windows detects the device and displays a Found New Hardware wizard.

Browse to and select the Drivers folder. The path will vary, depending on the computer's operating system and the location selected for software installation; for example:

- \Program Files (x86)\Motor Power Company \FLEXI SUITE\Drivers
- \Program Files\Motor Power Company \FLEXI SUITE\Drivers

The wizard will automatically select and install the driver file.

3. Look at the 7-segment display on the FLEXI PRO front panel.

Upon initial power up, the status display shows a flashing e, indicating that drive parameters are not yet configured. This fault will be cleared once the drive is configured.

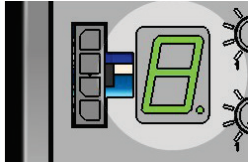

The digital display provides various indications of drive operation, such as operation modes, drive enable status, and fault conditions.

For more information, refer to the section Drive Status.

Drive Configuration

1. In FLEXI SUITE, select the Setup Wizard option from the navigation menu.
2. Follow the prompts to configure the FLEXI PRO for your particular motor and application.

Note: The wizard performs a basic drive configuration. For more advanced configuration options and procedures, refer to the user manual.

6 Drive Status

The 7-segment display provides various indications of drive status, such as operation modes, drive enable status, and fault conditions.

The display uses the following conventions:













- Decimal point – Enable/Disable status; if displayed, the drive is enabled.
- Steadily lit digit – Operation mode (OPMODE).
- Steadily lit letter – Warning.
- Sequential display of letters and digits – Fault, with some exceptions.
- Flashing – Fault.

Other Status Indications

- During the motor setup procedure, three characters are displayed in sequence (At1).
- The state of the software and hardware limit switches are indicated by a sequential display of characters (L1, L2, L3, L4).
- During the encoder initialization, a digit flashing at half-second intervals indicates the operation mode (OPMODE) currently in effect.

Normal Operation Codes

After the drive is configured and ready for operation, the display shows a steadily lit single digit, indicating the operation mode.

Display Name	Description	Drive Enabled	Drive Disabled
.	Drive enabled		
0	OPMODE 0 Serial velocity control mode		
1	OPMODE 1 Analog velocity control mode		
2	OPMODE 2 Serial current control mode		
3	OPMODE 3 Analog current control mode		
4	OPMODE 4 Master/slave gearing control mode		
8	OPMODE 8 Position control mode		

Display Name	Description	Drive Enabled	Drive Disabled
E	Ember Mode	Drive is in Ember mode; firmware is being downloaded to the drive.	

Warning and Fault Codes

The following table will help you interpret the warning and fault codes, and respond appropriately.

- Display is the code that appears on the drive's 7-segment display.
- Light distinguishes between a steadily lit character (for warnings) or a flashing character (for faults).
- Type specifies a warning or a fault.
- Name is the text message displayed in FLEXI SUITE.

Display	Light	Type	Name	Description	Action Required
≡	Flash	Fault	Watchdog Fault	Generally occurs due to an unforeseen circumstance. The drive is inoperable until power is cycled.	Contact technical support.
-1		Fault	Not Configured	Drive configuration required.	Set drive parameters and execute CONFIG.
-5		Fault	Motor Setup Failed	Motor Setup procedure failed (MOTORSETUPST will show the reason)	Check phase and motor wiring. Make sure to choose the correct feedback type, and follow the hints in MOTORSETUPST.
A4		Fault	CAN Supply Fault	A problem with the internal voltage supply for the CAN bus.	The drive probably needs repair. Contact technical support.
b	Flash	Fault	Drive Locked	Security code and key do not match. Fatal fault; drive cannot be operated.	Contact technical support.
b	Steady	Warning	Tamagawa Battery Low-Voltage	Battery voltage is nearing fault level.	Prepare to replace battery soon.
b1		Fault	PLL (phase-locked loop) Synchronization Failed	Controller synchronization signal is missing or not stable. The fault is detected only when synchronization is enabled by SYNCSOURCE command.	Check if controller provide synchronization signal. Check the cable connection and wiring.
C1		Fault	CAN Heartbeat Lost	Drive detected disconnection between CAN master and drive.	Reconnect master and slave, and power cycle the drive.
e	Flash	Fault	Parameter Memory Checksum Failure	The non-volatile memory used to store drive parameters is empty or the data is corrupted.	Reconfigure the drive, or download the parameter set, and save the parameters.
E	Flash	Fault	Failure Writing to Flash Memory	An internal problem accessing the flash memory. Fatal fault; drive cannot be operated.	Contact technical support.
e101		Fault	FPGA Config Fail	The code for the FPGA did not load. Fatal fault; drive cannot be operated.	Contact technical support.

Display	Light	Type	Name	Description	Action Required
e105		Fault	Self Test Fail	The power-up self test failed. Fatal fault; drive cannot be operated.	Contact technical support.
e106		Fault	Control EEPROM Fault	A problem accessing the EEPROM on the control board. Fatal fault; drive cannot be operated.	Contact technical support.
e107		Fault	Power EEPROM Fault	A problem accessing the EEPROM on the power board. Fatal fault; drive cannot be operated.	Contact technical support.
e108		Fault	Vbus Measure Circuit Fail	A failure occurred in the circuit that measures bus voltage.	Reset faults. If the fault persists, the drive probably needs repair. Contact technical support.
e109		Fault	Current-Sensors Offset Out-of-Range	The calculated offsets for the current sensors are out of range.	Reset faults. If the fault persists, the drive probably needs repair. Contact technical support.
e120		Fault	FPGA Version Mismatch	FPGA version does not match the firmware version	Update either the FPGA version or drive version
e121		Fault	Internal Error	Internal error due to an endless while loop or a numerical issue	Contact technical support.
F	Steady	Warning	Foldback	Drive fold current dropped below the drive fold current warning threshold (MIFOLDWTHRESH). Or, motor fold current dropped below the motor fold current warning threshold (IFOLDWTHRESH).	Check the drive-motor sizing. This warning can occur if the drive or the motor is under-sized (under-powered) for the application.
F1		Fault	Drive Foldback	Drive fold current dropped below the drive fold current fault threshold (MIFOLDFTHRESH).	Check motor-drive sizing. This fault can occur if the drive is under-sized (under-powered) for the application. Check that the commutation angle is correct (i.e., commutation is balanced). Check MIFOLDFTHRESH and MIFOLDWTHRESH values
F2		Fault	Motor Foldback	Motor fold current dropped below the motor fold current fault threshold. (IFOLDFTHRESH).	Check the drive-motor sizing. This fault can occur if the motor is under-sized (under-powered) for the application. Check IFOLDFTHRESH and IFOLDWTHRESH values.
F3		Fault	Stall Fault	A stall fault occurred because the motor was in a stalled state for too long; that is, [I > MICONT] and [I > 0.9 ILIM] and [V < STALLVEL] for [time > STALLTIME].	Remove the stall condition, and take care to prevent stall conditions.
Fb1		Fault	Fieldbus – Target position exceeds velocity limit	A target position command from controller was rejected because it would cause the motor to exceed the velocity limit.	Enable the drive and send valid position commands.
Fb2		Fault	Fieldbus – Target position exceeds acceleration/ deceleration limits	A target position command from controller was rejected because it would cause the motor to exceed the acceleration/ deceleration limit.	Enable the drive and send valid position commands.

Display	Light	Type	Name	Description	Action Required
Fb3		Fault	EtherCAT – Cable disconnected	The connection between controller and drive was removed.	Reestablish the connection between controller and drive.
Fb4		Fault	Fieldbus Target Command Lost	The fieldbus controller has not sent a target command in 3 consecutive instances.	Clear the fault and allow the controller to send new commands.
H	Flash	Fault	Motor Over-Temperature	Either the motor has overheated, or the drive is not set up correctly for the motor temperature sensor.	Check that the drive is configured properly (using THERMODE, THERMTYPE, THERMTHRESH and THERMTIME), and that the motor temperature sensor is properly connected to the drive if needed. If the drive is configured and wired properly, check whether the motor is under-sized for the application.
H	Steady	Warning	Motor Over-Temperature	Motor is overheated.	
j	Flash	Fault	Velocity Over-Speed Exceeded	Actual velocity exceeded 1.2 times the velocity limit. The velocity limit is set using VLIM.	Check that VLIM is set to match the application requirements. Using velocity loop tuning, check for excessive overshoot.
J1		Fault	Exceeded Maximum Position Error	The position error (PE) has exceeded the position error limit (PEMAX)	Change drive tuning to improve position tracking, or increase PEMAX to allow a greater position error.
J2		Fault	Exceeded Maximum Velocity Error	The velocity error (VE) has exceeded the velocity error limit (VEMAX)	Change drive tuning to improve velocity tracking, or increase VEMAX to allow a greater velocity error.
L1		Warning	Hardware positive limit switch is open	Positive hardware limit switch is activated.	
L2		Warning	Hardware negative limit switch is open	Negative hardware limit switch is activated.	
L3		Warning	Hardware positive and negative limit switches are open	Positive and negative hardware limit switches are both activated.	
L4		Warning	Software positive limit switch is tripped	Positive software limit switch is activated. PFB > POSLIMPOS and POSLIMMODE = 1	
L5		Warning	Software negative limit switch is tripped	Negative software limit switch is activated. PFB < POSLIMNEG and POSLIMMODE = 1	
L6		Warning	Software limit switches are tripped	Positive and negative software limit switches are activated. PFB > POSLIMPOS and PFB < POSLIMNEG and POSLIMMODE = 1	
n	Flash	Fault	STO Fault	The STO signal is not connected when drive enabled.	Check that the STO connector (P1) is wired correctly.
n	Steady	Warning	STO	The STO signal is not connected when drive disabled.	Check that the STO connector (P1) is wired correctly.

Display	Light	Type	Name	Description	Action Required
n1		Fault	Regen Over-Current	The preset current limit for regen current has been exceeded.	Increase the value of the regen resistor.
n3		Fault	Emergency Stop Issued	The input defined as emergency stop has been activated.	Turn off the specific input.
n41		Fault	Power Brake Open Load	Open load on the power brake output	Make sure the power brake load cables are connected properly and are not damaged.
n42		Fault	Power Brake Short	Short circuit on the power brake output	Replace the power brake (the motor).
o	Flash	Fault	Over-Voltage	The bus voltage exceeded the maximum value.	Check whether a regen resistor is required for the application.
o15		Fault	Plus 15V Out of Range	The internal +15 V supply is out of range.	The drive probably needs repair. Contact technical support.
o-15		Fault	Minus 15V Out of Range	The internal -15 V supply is out of range.	The drive probably needs repair. Contact technical support.
o5		Fault	5V Out of Range	5V is low or powering off.	May occur during power off. If occurs otherwise, contact technical support.
P		Fault	Over-Current	Over-current at the drive output has been detected. The drive allows this fault to occur up to 3 times in succession. After 3 faults, the drive forces a delay of 1 minute before it can be reenabled.	Check for a short circuit on the motor connection. Check for excessive overshoot in the current loop.
r	Steady	Warning	Offset and/or Gain Adjustment Values Detected After SININIT	Significant offset and/or gain adjustment values were detected after SININIT. The values that trigger this warning are half the value of those used to declare a fault. Although the system may continue to function, these values indicate the existence of a problem, which may worsen over time.	Check the encoder and associated hardware. These values suggest some degradation in either electronics (e.g., encoder, drive) or wiring (e.g., increased wire resistance, increased leakage between wires). The problem must be analyzed and repaired.
r10		Fault	Sine Feedback Communication Fail	Communication problem between the drive and the EnDat encoder.	Check that the data and clock signals to the EnDat encoder are connected properly. The cable must be shielded.
r14		Fault	Sine Encoder Quadrature Fault	Mismatch between calculated and actual encoder quadrature information.	Check the feedback device wiring. Check that the correct encoder type (MENCTYPE) is selected.
r15		Fault	Sin/Cos Calibration Invalid	The sine/cosine calibration parameters are out of range. This fault is related to resolver and sine encoder feedback.	Re-execute the sine/cosine calibration process.

Display	Light	Type	Name	Description	Action Required
r16		Fault	Feedback 5V Over-Current	The current supplied by the drive on the 5V primary encoder supply has exceeded the preset current limit. The drive allows this fault to occur up to 3 times in succession. After 3 faults, the drive forces a delay of 1 minute before it can be reenabled.	The FLEXI PRO can source a maximum current of 250 mA to the primary encoder. Check for a short-circuit at the encoder. Check if the encoder is drawing more than the current limit.
r17		Fault	Secondary Feedback Index Break	Secondary encoder index line not connected.	Check whether the drive is configured for working with the index signal on the secondary encoder, and check if the index signal is connected.
r18		Fault	Secondary Feedback A/B Line Break	One of the secondary feedback signals is not connected.	Check that all signals from the secondary encoder are properly connected to the drive.
r19		Fault	Secondary Feedback 5V Over-Current	The preset current limit for current supplied by the drive on the 5 V secondary encoder supply has been exceeded.	The FLEXI PRO can source a maximum current of 250 mA to the secondary encoder. Check for a short-circuit at the encoder. Check if the encoder is drawing more than the current limit.
r20		Fault	Feedback Communication Error	Communication with the feedback device did not initialize correctly.	Check that the feedback device is wired correctly. Check that the correct encoder type (MENCTYPE) is selected.
r21		Fault	Nikon Encoder Operational Fault	Communication with the Nikon MAR-A40A feedback device did not initialize correctly.	Check that the feedback device is wired correctly. Check that the correct encoder type (MENCTYPE) is selected.
r23		Fault	Phase Find Failed	Commutation initialization has failed. This fault occurs in systems that do not have commutation information (e.g., Hall signals) in the motor feedback device.	Check whether the motor feedback type and the phase-finding parameters are set correctly for the application.
r24		Fault	Tamagawa Init Failed	The initialization process with the Tamagawa feedback device has failed.	Check that the wiring to the encoder is correct.
r25		Fault	Pulse & Direction Input Line Break	One of the Pulse & Direction signals is not connected.	Check that all signals to the P&D inputs are properly connected to the drive.
r26		Fault	Tamagawa Abs Operational Fault	Several faults are indicated by the feedback device and include one or more of the following: battery low/error, over-speed, counting error, multi-turn error	Check the battery voltage and feedback wiring. Make sure the motor did not move at a high velocity during encoder initialization.
r27		Fault	Motor Phases Disconnected	One of the motor phases is disconnected. The current of one of the motor phases is effectively zero for more than 160 electrical degrees while the current command is greater than 100.	Check the wiring of the motor phases.

Display	Light	Type	Name	Description	Action Required
r28		Fault	Resolver Initialization Failed	The drive could not detect the proper gain setting or sampling point for the sine/cosine signals.	Check resolver wiring and gain value.
r29		Fault	Absolute Encoder Battery Low-Voltage	An error bit indicating a battery problem was detected in data from the drive.	Replace battery, then reset drive. If battery is replaced while drive is on, position information is retained.
r34		Fault	PFB Off Checksum Invalid	The calculated checksum of the PFB backup data does not match the expected checksum.	If required by the application, home the machine.
r35		Fault	PFB Off Data Mismatch	Multiturn data of the PFB cannot be restored due to axis movement.	If required by the application, home the machine.
r36		Fault	No PFB Off Data	PFB backup memory is empty.	If required by the application, home the machine.
r37		Fault	Encoder Phase Error	In normal incremental encoder operation, quadrature inputs A and B are 90 degrees out of phase. The phase error occurs when edge transition is detected simultaneously on the A and B signals.	Set MENCAQBFILT to 0 to remove the filter on A and B signals. If problem persists, it may be due to a faulty encoder.
r38		Fault	Differential Halls Line Break	Line break in differential Hall sensors.	Make sure HALLSTYPE matches the Hall sensors in use (single-ended or differential). Check whether all signals from the differential Hall sensors are properly connected to the drive.
r4		Fault	A/B Line Break	One of the primary feedback signals is not connected. This fault occurs in incremental encoder, resolver and sine encoder feedback types.	Check whether all signals from the primary feedback device are properly connected to the drive.
r5		Fault	Index Line Break	Encoder index line is not connected.	Check that the drive is configured for working with the index signal (using MENCTYPE), and check if the index signal is connected.
r6		Fault	Illegal Halls	The drive has detected either 000 or 111 state on the Hall feedback signals.	Check that the Hall signals are all properly connected. While turning the motor, read the Halls state (using HALLS) to see which signal is not connected. If the feedback type is Tamagawa, check that the feedback wiring is correct
r8		Fault	A/B Out of Range	Feedback analog signal is out of range. This fault is related to resolver and sine encoder feedback. The drive checks that the amplitudes of the sine and cosine signals are correct, based on the calculation $\sin^2 + \cos^2 = 1$	Check the amplitudes of the sine and cosine signals.

Display	Light	Type	Name	Description	Action Required
r9		Fault	Encoder Simulation Freq Too High	The computed equivalent encoder output frequency exceeds the upper limit for this signal, which is 4 MHz.	Check the parameters used for setting up the equivalent encoder output. If using a sine encoder, check the ENCOUTRES parameter settings.
t	Steady	Warning	Over-Temperature	The temperature on the power board and/or on the control board has exceeded the preset limit.	Check if the ambient temperature exceeds the drive specification. Otherwise contact technical support.
t1		Fault	Power Stage Over-Temperature	The temperature on the power board has exceeded the preset limit.	Check if the ambient temperature exceeds the drive specification. Otherwise contact technical support.
t2		Fault	Power Module Over-Temperature	The temperature inside the integrated power module has exceeded the preset limit.	Check if the ambient temperature exceeds the drive specification. Otherwise contact technical support.
t3		Fault	Control Board Over-Temperature	The temperature on the control board has exceeded the preset limit.	Check if the ambient temperature exceeds the drive specification. Otherwise contact technical support.
u	Flash	Fault	Under-Voltage	The bus voltage is below the minimum value.	Check that the main AC voltage supply is connected to the drive and is switched on. The under-voltage limit can be read with the UVTHRESH command.
u	Steady	Warning	Under-Voltage	The bus voltage is below the minimum value.	Check that the main AC voltage supply is connected to the drive and is switched on. Verify that the setting of UVMODE is correct.
		Warning	Encoder Hall Switch Not Found	Hall switch not yet detected.	
		Warning	Encoder Index Not Detected	Index not yet detected.	
		Warning	HIPERFACE Encoder Resolution Mismatch	Encoder resolution, as determined from the detected HIPERFACE device information, is different from the current settings of MENCRES	Enter the correct resolution (MENCRES value).
		Warning	HIPERFACE Device Not Supported	The detected HIPERFACE device is not supported	Contact technical support.
		Warning	HIPERFACE Device Unknown	HIPERFACE encoder type information is not recognized	Contact technical support.
		Warning	Phase Find Required	Phase difference is required to initialize the commutation angle	Perform phase find.

FLEXI PRO Servo Drive

Quick Start Guide

Revision 5.6

Motor Power Company s.r.l.
Via Leonardo Da Vinci , 4
42024 Castelnovo Sotto
Reggio Emilia - Italia
Tel: +39 0522 682710
Fax: +39 0522 683552
Website: www.motorpowerco.com