



TETRA COMPACT - E
AND FLEXI - PRO
THE ENHANCED SERVO BUNDLE

MOTION CONTROL

***MOTOR
POWER***
COMPANY



Motor Power Company
www.motorpowerco.com
info@motorpowerco.it

All rights reserved.
Complete or partial reproduction
is not allowed without our permission.

All technical data in this catalog
may be changed without prior notice.

SEE IT BEFORE IT HAPPENS

**MOTOR
POWER**
COMPANY

**WELCOME TO
MOTOR POWER COMPANY**

Motor Power Company introduces its new brushless servo bundle: **TETRA COMPACT-ENHANCED**, brushless servomotors, perfectly matched with the **FLEXI-PRO** digital drives range. Featuring the newest engineering and manufacturing technology, these enhanced servomotors and drives provide high dynamic response for any automation need. A careful selection of components, highest quality standard and international certifications assure that this series is optimum for a responsive, accurate and reliable automation. The bundle supports an innovative and patented 20 bit absolute magnetic encoder, featuring compactness, high resolution and accuracy, for high end application requirements. TETRA COMPACT-E brushless servo motors are the result of a completely new design and a modern production concept: uncompromised quality, international certifications and a wide range of power ratings make these servo motors and drives ideal for modern machine performance needs.

FEATURES AND BENEFITS

Synchronous brushless servomotor

Flange dimensions: 40 - 60 - 80 - 100 - 130 - 180 mm

0.16 Nm to 45 Nm rated torque

50 W to 7,5 kW rated output power

Rated winding voltage 230 Vac and 400 Vac

Maximum servomotor speed up to 6000rpm

Built-in 20 bit proprietary absolute magnetic encoder

TTL encoder, absolute multiturn encoder (Hiperface), also available.

Insulation class F (155 °C)

IP 65 (with oil seal)

Shaft balancing class G 2,5 according ISO 1940

Ambient operation temperature from -20° C to +40° C

Optional holding brake

Optional shaft sealing

Ral 9005 black powder coating

UL [UL 1004], CSA, CE, Rohs certified

Reach compliance

TETRA COMPACT-Enhanced

PRODUCT LINEUP

Servomotor Type	Nominal Power P_n	Nominal Torque M_n	Peak Torque M_{max}	Nominal Working Speed nM	Maximum Working Speed nMax	Moment of inertia	Drive type 230 Vac	Drive type 400 Vac
	[W]	[Nm]	[Nm]	[min ⁻¹]	[min ⁻¹]			
TC-E 40 1A	50	0,16	0,48	3000	6000	Medium	FLEXI PRO 1D5	FLEXI PRO 003
TC-E 40 1B	100	0,32	0,96	3000	6000	Medium	FLEXI PRO 1D5	FLEXI PRO 003
TC-E 60 2A	200	0,64	1,92	3000	6000	Low	FLEXI PRO 1D5	FLEXI PRO 003
TC-E 60 2B	400	1,27	3,81	3000	6000	Low	FLEXI PRO 003	FLEXI PRO 003
TC-E 80 3A	400	1,27	3,81	3000	6000	Low	FLEXI PRO 003	FLEXI PRO 003
TC-E 80 3B	750	2,39	7,16	3000	6000	Low	FLEXI PRO 4D5	FLEXI PRO 003
TC-E 100 4A	1000	3,18	9,54	3000	6000	Low	FLEXI PRO 006	FLEXI PRO 006
TC-E 100 4B	2000	6,37	19,11	3000	6000	Low	FLEXI PRO 010	FLEXI PRO 006
TC-E 130 5A	500	2,39	7,16	2000	3000	Medium	FLEXI PRO 003	FLEXI PRO 003
TC-E 130 5B	300	2,86	8,59	1000	2000	Medium	FLEXI PRO 003	FLEXI PRO 003
TC-E 130 5C	950 1000	4,77	14,3	2000	4000	Medium	FLEXI PRO 006 FLEXI PRO 010	FLEXI PRO 006
TC-E 130 5D	810 850	5,39	13,8	1500	3000	Medium	FLEXI PRO 006 FLEXI PRO 010	FLEXI PRO 006
TC-E 130 5E	600	5,73	17,19	1000	2000	Medium	FLEXI PRO 006	FLEXI PRO 006
TC-E 130 5F	870 900	8,59	25,77	1000	2000	Medium	FLEXI PRO 006 FLEXI PRO 010	FLEXI PRO 006
TC-E 130 5G	1350 1500	7,16	21,48	2000	3000	Medium	FLEXI PRO 006 FLEXI PRO 010	FLEXI PRO 006 FLEXI PRO 012
TC-E 130 5H	2000	9,55	28,65	2000	5000	Medium	FLEXI PRO 013	FLEXI PRO 012
TC-E 180 6A	2000	9,55	28,65	2000	4000	Medium	FLEXI PRO 010	FLEXI PRO 012
TC-E 180 6B	3000	14,32	42,97	2000	4000	Medium	FLEXI PRO 020	FLEXI PRO 024
TC-E 180 6C	3000	19,1	57,29	1500	4000	Medium	FLEXI PRO 020	FLEXI PRO 024
TC-E 180 6D	3500	16,7	50,3	2000	4000	Medium	FLEXI PRO 024	FLEXI PRO 024
TC-E 180 6E	4500	28,65	71,62	1500	4000	Medium	FLEXI PRO 024	FLEXI PRO 024
TC-E 180 6F	5500	35,01	87,53	1500	4000	Medium	-	FLEXI PRO 024
TC-E 180 6G	7500	47,75	119,37	1500	4000	Medium	-	FLEXI PRO 030

SEE IT BEFORE IT HAPPENS

TETRA COMPACT-E SERVOMOTOR TYPE

TC-E	040 1B	C1	2	0	A2	0	D0	XX
Model		Winding Code	Winding Voltage	Mechanical Arrangement	Feedback	Brake	Connection	Optional
1		2	3	4	5	6	7	8



1	Model	See product lineup																						
2	Winding Code	B1	C1	D1	D2	D3	D4	D5	D6	E2	F1	F2	F3	F4	G1	G2	G3	G4	G5	H1	H3	L1	L2	M1
	Motor																							
	TC-E 040 1A	• & Δ																						
	TC-E 040 1B		• & Δ																					
	TC-E 060 2A																							
	TC-E 060 2B																							
	TC-E 080 3A																							
	TC-E 080 3B																							
	TC-E 100 4A																							
	TC-E 100 4B																							
	TC-E 130 5A																							
	TC-E 130 5B																							
	TC-E 130 5C																							
	TC-E 130 5D																							
	TC-E 130 5E																							
	TC-E 130 5F																							
	TC-E 130 5G																							
	TC-E 130 5H																							
	TC-E 180 6A																							
	TC-E 180 6B																							
	TC-E 180 6C																							
	TC-E 180 6D																							
	TC-E 180 6E																							
	TC-E 180 6F																							
	T C-E 180 6G																							

3 2 - • 230 Vac
 4 - Δ 400 Vac

4 Mechanical Arrangement

0 - Smooth shaft	4 (*) - High inertia smooth shaft
1 - Smooth shaft + oil seal	5 (*) - High inertia smooth shaft + oil seal
2 - Keyed shaft	6 (*) - High inertia keyed shaft
3 - Keyed shaft + oil seal	7 (*) - High inertia keyed shaft + oil seal

(**) available for models TC-E 80 3B D4 2, TC-E 80 3B F3 4, TC-E 130 5C F1 2, TC-E 130 5C F1 4, TC-E 180 6A G2 2, TC-E 180 6A G3 4 only

5 Feedback

E1 (*) - Encoder TTL 2500ppr
A1 - Absolute multiturn encoder (Hiperface)
A2 - Proprietary 20 bit absolute encoder

(*) not available for TC-E 40 models

6 Brake

0 - Without brake
1 - With brake

7 Connection

D0 - 300mm output cable length with plastic connector (TC-E 40, 60, 80)
C2 - 90° M23 turnable connectors (TC-E 60, 80, 100, 130, 180 models 6A, 6B, 6C, 6D)
C3 - MS connectors (TC-E 100, 130, 180)

FLEXI PRO DRIVE TYPE

FPRO **006** **2A** **AP** **1** **XX**

Drive Name Rating AC and Controller input Power Supply Interface Options Analog Input Special Specification

1 **2** **3** **4** **5**



1

Rating		
120/240 VAC		
	Cont. [A rms]	Peak [A rms]
1D5	1.5	4.5
003	3	9
4D5	4,5	18
006	6	18
008	8	28
010	10	28
013	13	28
020	20	48
024	24	48

Rating		
400/480 VAC		
	Cont. [A rms]	Peak [A rms]
003	3	9
006	6	18
012	12	24
024	24	72
030	30	90

2

AC and Controller Input Power Supply	
2A	Input Single Phase 120L - L VAC +10% -15% 50/60Hz
	Input Single Phase 240L - L VAC +10% -15% 50/60Hz
	Input Three Phase 120 - 240L - L VAC +10% -15% 50/60Hz
4D	AC Input Power Supply:
	- Input Three Phase 400L - L VAC +10% -15% 50/60Hz
	- Input Three Phase 480L - L VAC +10% -15% 50/60Hz
	24VDC input for control board power supply

3

Interface Options

AF - Analog Voltage/Pulse Train Ref & CANopen® & USB & RS 232
 EC - EtherCAT, USB, RS232
 EB - EtherCAT, USB (two analog inputs only)

4

Analog Input

1 - One Analog input, 16 bit
 2 - Two Analog inputs, 14 bit each

PATENTED MAGNETIC ENCODER

The original magnetic encoder features a simple mechanical design that allows the same level of resolution and accuracy as optical absolute encoders whilst reducing complexity.

The simplicity is the key to achieving compactness, high resolution and accuracy at a competitive cost. This original encoder offers a resolution of 20 bit and an accuracy of $\pm 0.02^\circ$. Advanced signal processing applies a unique patented method.

Featuring only few mechanical components and no optical elements, the encoder is less sensitive to contamination and mechanical tolerance deviations. Furthermore, lifetime expectancy of the encoder is higher due to the elimination of both optical components and bearings.



SEE IT BEFORE IT HAPPENS



The FLEXI PRO series features a high-performance digital servo drive offering advanced functionality, high power density and seamless commissioning in a superior package. The innovative hardware design and software algorithms boast outstanding performance in one of the smallest footprints in the market.

FEATURES

- > **INNOVATIVE AND PATENTED 20 BIT ABSOLUTE MAGNETIC ENCODER**
- > **MULTIFEDBACK**
- > **DIGITAL I/O: 11 DIGITAL INPUT AND 6 OUTPUT CUSTOMIZABLE WITH SEVERAL BUILT-IN FUNCTIONS AND INTERNAL SCRIPT**
- > **CONTROL: HD ADVANCED CONTROL LOOP WITH ADAPTIVE GAINS**
- > **SERVO MODES: TORQUE, VELOCITY AND POSITION WITH S-CURVE PROFILE**
- > **STO SIL 2**
- > **INTEGRATED SUPPORT FOR EXTERNAL BRAKING RESISTOR**
- > **COMPLETE MOTOR DATABASE**

BENEFITS

- > **INTELLIGENT AUTO-TUNING - MINIMIZES POSITION ERROR AND SETTLING TIME TO ALMOST ZERO**

Engineering experience and expertise has been implemented in a sophisticated Auto-Tuning function that performs optimal configurations for a difference-making performance

- > **NEW CURRENT LOOP DESIGN - ACHIEVES AN INDUSTRY-LEADING FREQUENCY RESPONSE OF UP TO 3.0 KHZ**

Rapid control loop sample rates and flexible filtering options provide a faster response, and ensure maximum machine accuracy and throughput

- > **INNOVATIVE ANTI-VIBRATION ALGORITHM - ELIMINATES MECHANICAL RESONANCE**

An active-non-linear algorithm eliminates vibration in highly flexible resonant systems. Commissioning is easy since only few gain parameters are required



INTERFACE

- > **USB WITH DAISY CHAIN CAPABILITY**
- > **PULSE & DIRECTION**
- > **ANALOG VELOCITY AND TORQUE COMMAND $\pm 10V$**
- > **CANopen**
- > **EtherCAT**

FLEXIBLE AND COMPREHENSIVE

PRODUCT DATA

FEATURE	UNITS	FPRO 1D5	FPRO 003	FPRO 4D5	FPRO 006	FPRO 008	FPRO 010	FPRO 013	FPRO 020	FPRO 024	FPRO 003	FPRO 006	FPRO 012	FPRO 024	FPRO 030			
Input Voltage	VAC	120/240 VAC Single Phase			240 VAC Single or Three Phase				120/240 VAC Three Phase			400/480 VAC Three Phase						
Max Continuous power output	W	350	700	1000	1400	1800	2300	3000	4500	5500	1100	2200	4400	9000	11000			
Efficiency at rated Power	%	> 90																
Auxiliary Supply Voltage		120 .. 240 Vac									24 Vdc							
Continuous current rms	A rms	1,5	3	4,5	6	8	10	13	20	24	3	6	12	24	30			
Peak current	A rms	4,5	9	18	18	28	28	28	48	48	9	18	24	72	90			
Ambient Operating Temperature	°C	0 to + 45																
Maximum Humidity	%	90% not condensing																
Vibration		0.6G 10-60 Hz																
Shock		1 G																
Mounting Method		Wall Mount																
Dimensions	WxDxH mm	43x144x150			55x167x150			62x182x170			117x194x234			110x193x163			FPRO 012 117x194x234	
																FPRO 024 - FPRO 030 147x209x353		
Weight	Kg	0,7	0,75	0,97	0,97	1,15	1,15	1,15	3,2	3,2	2,1	2,1	3,2	10,5	10,5			

FLEXI PRO SUITE

> SIMPLIFIES SETUP, TESTING AND TUNING

User-friendly FLEXI SUITE software provides step-by-step guidance through the setup and tuning process. Setup and testing are intuitive thanks to auto-tuning functions and graphic representations of control loops

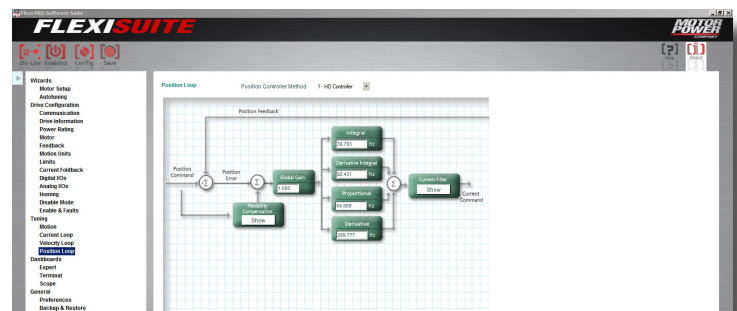

TETRA COMPACT-E 40

230 Vac RATINGS AND SPECIFICATIONS

TIME RATING
INSULATION CLASS
ENCLOSURE
PROTECTION CLASS

Continuous
F
Totally enclosed. Self-cooled
IP 54 Standard
IP 65 with shaft sealing

AMBIENT TEMPERATURE
RELATIVE HUMIDITY
POLES
CERTIFICATION

-20 ... + 40 °C
5 ... 85% (non-condensing)
8
UL 1004, CSA, CE and Rohs approved
Reach compliance

TC-E 40 1A B1 2 TC-E 40 1B C1 2

Continuous stall torque	M_0	Nm	0,16	0,32
Peak torque	M_{max}	Nm	0,48	0,96
Nominal working speed	nN	min ⁻¹	3000	3000
Maximum working speed	nmax	min ⁻¹	6000	6000
Nominal torque	M_n	Nm	0,16	0,32
Nominal current	I_N	A _{rms}	0,59	0,89
Nominal power	P_N	kW	0,05	0,10
Rated winding voltage	U_n	V _{ac}	230	230
Maximum winding voltage	U_{max}	V _{dc}	360	360
Maximum voltage to ground		V _{ac}	255	255
Maximum current	I_{max}	A _{rms}	1,80	2,70
Continuous stall current	I_0	A _{rms}	0,54	0,81
Voltage Constant	K_{eU-v}	Vrms/Krpm	18	24
Torque Constant	k_t	Nm/A _{rms}	0,30	0,40
Winding resistance	R_{20U-v}	Ohm	31,0	23,4
Winding inductance	L_{qu-v}	mH	26,4	21,5
Winding inductance	L_{du-v}	mH	24,7	20,6
Rotor inertia without holding brake	J_M	Kgcm ²	0,044	0,065
Rotor inertia with holding brake	J_M	Kgcm ²	0,045	0,066
Mass without holding brake	m	Kg	0,4	0,56
Mass with holding brake	m	Kg	0,6	0,77
Thermal time constant	Tth	min	10	15
Maximum radial shaft load		N	85	85
Maximum axial shaft load		N	40	40

Rated output with 185x185x8mm aluminum heat sink flange coupling - Ambient temperature 40°C - Derating must be considered if the oil seal is applied

SEE IT BEFORE IT HAPPENS

TETRA COMPACT-E 40

400 Vac RATINGS AND SPECIFICATIONS

TIME RATING	Continuous	AMBIENT TEMPERATURE	-20 ... + 40 °C
INSULATION CLASS	F	RELATIVE HUMIDITY	5 ... 85% (non-condensing)
ENCLOSURE	Totally enclosed. Self-cooled	POLES	8
PROTECTION CLASS	IP 54 Standard IP 65 with shaft sealing	CERTIFICATION	UL 1004, CSA, CE and Rohs approved Reach compliance

TC-E 40 1A B1 4 TC-E 40 1B C1 4

Continuous stall torque	M_0	Nm	0,16	0,32
Peak torque	M_{max}	Nm	0,48	0,96
Nominal working speed	nN	min ⁻¹	3000	3000
Maximum working speed	nmax	min ⁻¹	6000	6000
Nominal torque	M_n	Nm	0,16	0,32
Nominal current	I_N	A _{rms}	0,59	0,89
Nominal power	P_N	kW	0,05	0,10
Rated winding voltage	U_n	V _{ac}	400	400
Maximum winding voltage	U_{max}	V _{dc}	650	650
Maximum voltage to ground		V _{ac}	265	265
Maximum current	I_{max}	A _{rms}	1,80	2,70
Continuous stall current	I_0	A _{rms}	0,54	0,81
Voltage Constant	K_{eu-v}	V _{rms} /Krpm	18	24
Torque Constant	k_t	Nm/A _{rms}	0,30	0,40
Winding resistance	R_{20u-v}	Ohm	31,0	23,4
Winding inductance	L_{qu-v}	mH	26,4	21,5
Winding inductance	L_{du-v}	mH	24,7	20,6
Rotor inertia without holding brake	J_M	Kgcm ²	0,044	0,065
Rotor inertia with holding brake	J_M	Kgcm ²	0,045	0,066
Mass without holding brake	m	Kg	0,4	0,56
Mass with holding brake	m	Kg	0,6	0,77
Thermal time constant	Tth	min	10	15
Maximum radial shaft load		N	85	85
Maximum axial shaft load		N	40	40

Rated output with 185x185x8mm aluminum heat sink flange coupling - Ambient temperature 40°C - Derating must be considered if the oil seal is applied

TETRA COMPACT-E 40

230-400 Vac TORQUE AND SPEED CHARTS

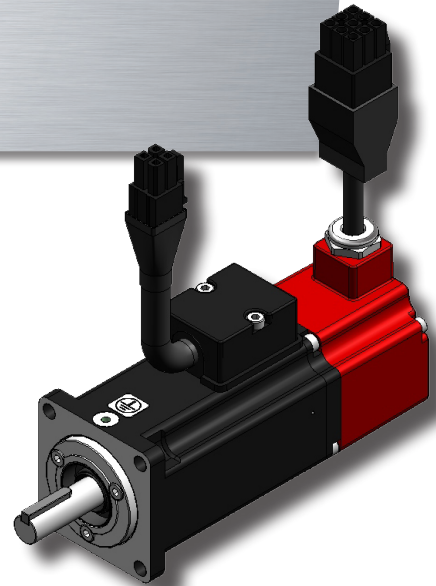

TETRA COMPACT-E 40 1A B1 2

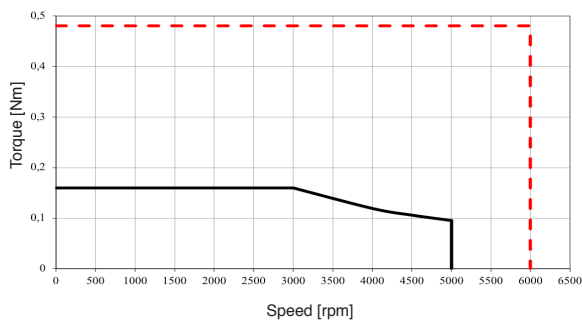

TETRA COMPACT-E 40 1B C1 2

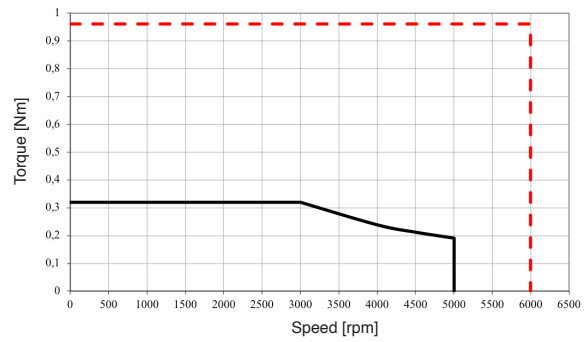

TETRA COMPACT-E 40 1A B1 4

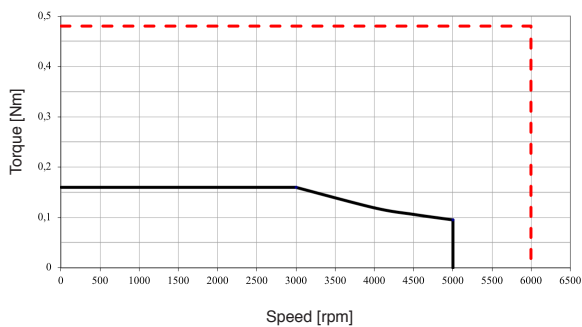

TETRA COMPACT-E 40 1B C1 4

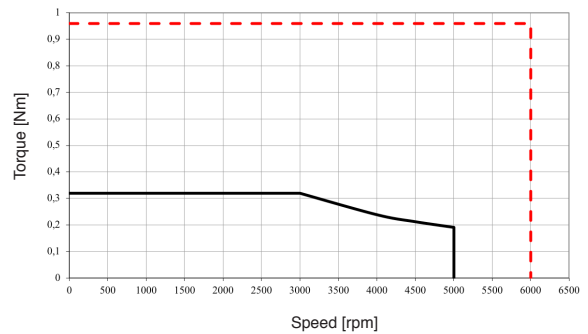

SEE IT BEFORE IT HAPPENS



— Continuous torque
 - - - Peak torque

TETRA COMPACT-E 60

230 Vac RATINGS AND SPECIFICATIONS

TIME RATING	Continuous	AMBIENT TEMPERATURE	-20 ... + 40 °C
INSULATION CLASS	F	RELATIVE HUMIDITY	5 ... 85% (non-condensing)
ENCLOSURE	Totally enclosed. Self-cooled	POLES	8
PROTECTION CLASS	IP 54 Standard IP 65 with shaft sealing	CERTIFICATION	UL 1004, CSA, CE and Rohs approved Reach compliance

TC-E 60 2A D3 2 TC-E 60 2B D3 2

Continuous stall torque	M_0	Nm	0,64	1,27
Peak torque	M_{max}	Nm	1,92	3,81
Nominal working speed	nN	min ⁻¹	3000	3000
Maximum working speed	nmax	min ⁻¹	6000	6000
Nominal torque	M_n	Nm	0,64	1,27
Nominal current	I_N	A_{rms}	1,30	2,50
Nominal power	P_N	kW	0,20	0,40
Rated winding voltage	U_n	V_{ac}	230	230
Maximum winding voltage	U_{max}	V_{dc}	360	360
Maximum voltage to ground		V_{ac}	255	255
Maximum current	I_{max}	A_{rms}	4,50	7,80
Continuous stall current	I_0	A_{rms}	1,11	2,19
Voltage Constant	K_{eu-v}	Vrms/Krpm	35	35
Torque Constant	k_t	Nm/ A_{rms}	0,58	0,58
Winding resistance	R_{20u-v}	Ohm	12,2	5,2
Winding inductance	L_{qu-v}	mH	24,8	12,5
Winding inductance	L_{du-v}	mH	22,7	12
Rotor inertia without holding brake	J_M	Kgcm ²	0,15	0,26
Rotor inertia with holding brake	J_M	Kgcm ²	0,16	0,27
Mass without holding brake	m	Kg	1,02	1,45
Mass with holding brake	m	Kg	1,5	2
Thermal time constant	Tth	min	15	20
Maximum radial shaft load		N	200	200
Maximum axial shaft load		N	70	70

Rated output with 250x250x12mm aluminum heat sink flange coupling - Ambient temperature 40°C - Derating must be considered if the oil seal is applied

TETRA COMPACT-E 60

400 Vac RATINGS AND SPECIFICATIONS

TIME RATING	Continuous	AMBIENT TEMPERATURE	-20 ... + 40 °C
INSULATION CLASS	F	RELATIVE HUMIDITY	5 ... 85% (non-condensing)
ENCLOSURE	Totally enclosed. Self-cooled	POLES	8
PROTECTION CLASS	IP 54 Standard IP 65 with shaft sealing	CERTIFICATION	UL 1004, CSA, CE and Rohs approved Reach compliance

TC-E 60 2A D3 4

TC-E 60 2B D3 4

Continuous stall torque	M_0	Nm	0,64	1,27
Peak torque	M_{max}	Nm	1,92	3,81
Nominal working speed	nN	min ⁻¹	3000	3000
Maximum working speed	nmax	min ⁻¹	6000	6000
Nominal torque	M_n	Nm	0,64	1,27
Nominal current	I_N	A_{rms}	1,30	2,50
Nominal power	P_N	kW	0,20	0,40
Rated winding voltage	U_n	V_{ac}	400	400
Maximum winding voltage	U_{max}	V_{dc}	650	650
Maximum voltage to ground		V_{ac}	265	265
Maximum current	I_{max}	A_{rms}	4,50	7,80
Continuous stall current	I_0	A_{rms}	1,11	2,19
Voltage Constant	K_{eu-v}	Vrms/Krpm	35	35
Torque Constant	k_t	Nm/ A_{rms}	0,58	0,58
Winding resistance	R_{20u-v}	Ohm	12,2	5,2
Winding inductance	L_{qu-v}	mH	24,8	12,5
Winding inductance	L_{du-v}	mH	22,7	12
Rotor inertia without holding brake	J_M	Kgcm ²	0,15	0,26
Rotor inertia with holding brake	J_M	Kgcm ²	0,16	0,27
Mass without holding brake	m	Kg	1,02	1,45
Mass with holding brake	m	Kg	1,5	2
Thermal time constant	Tth	min	15	20
Maximum radial shaft load		N	200	200
Maximum axial shaft load		N	70	70

Rated output with 250x250x12mm aluminum heat sink flange coupling - Ambient temperature 40°C - Derating must be considered if the oil seal is applied

SEE IT BEFORE IT HAPPENS

**MOTOR
POWER**
COMPANY

TETRA COMPACT-E 60

230-400 Vac TORQUE AND SPEED CHARTS

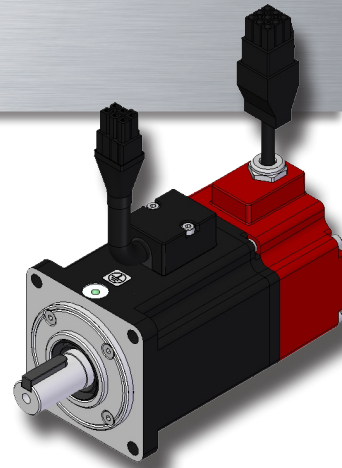

TETRA COMPACT-E 60 2A D3 2

TETRA COMPACT-E 60 2B D3 2

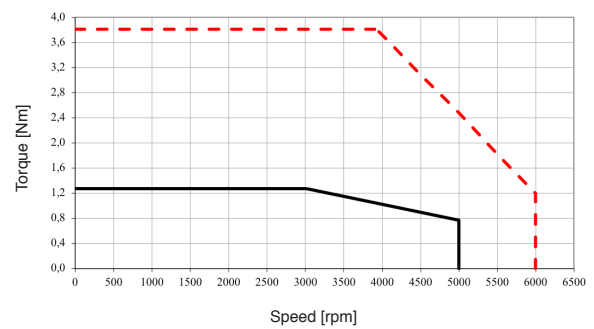
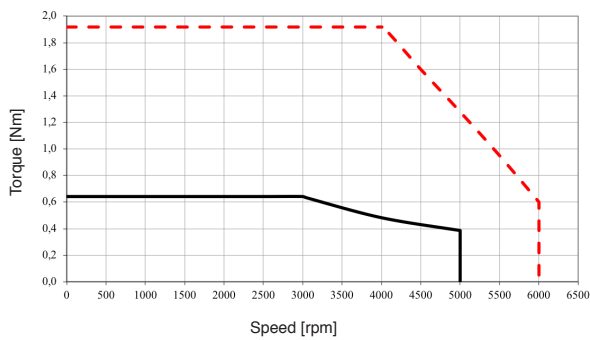

TETRA COMPACT-E 60 2A D3 4

TETRA COMPACT-E 60 2B D3 4

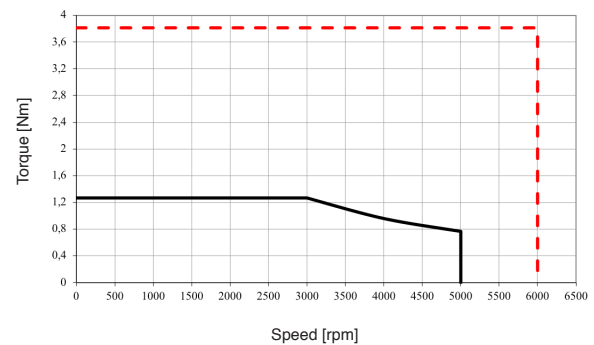
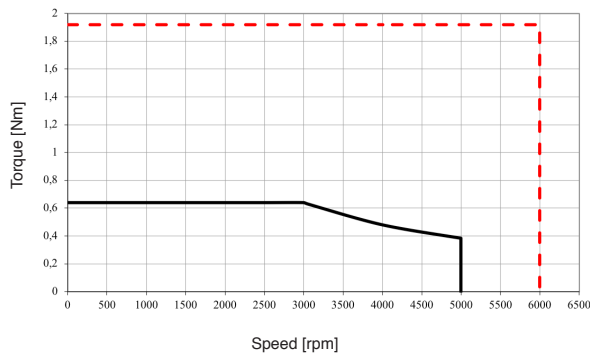

Continuous torque
 Peak torque

SEE IT BEFORE IT HAPPENS



TETRA COMPACT-E 60 DIMENSIONS

TC-E 60 2A

TC-E 60 2B

L without brake with feedback A2	mm	104	129
L with brake with feedback A2	mm	140	165
L without brake with feedback A1	mm	114	139
L with brake with feedback A1	mm	150	175
Z without brake	mm	57	82
Z with brake	mm	57	82

D0 connection

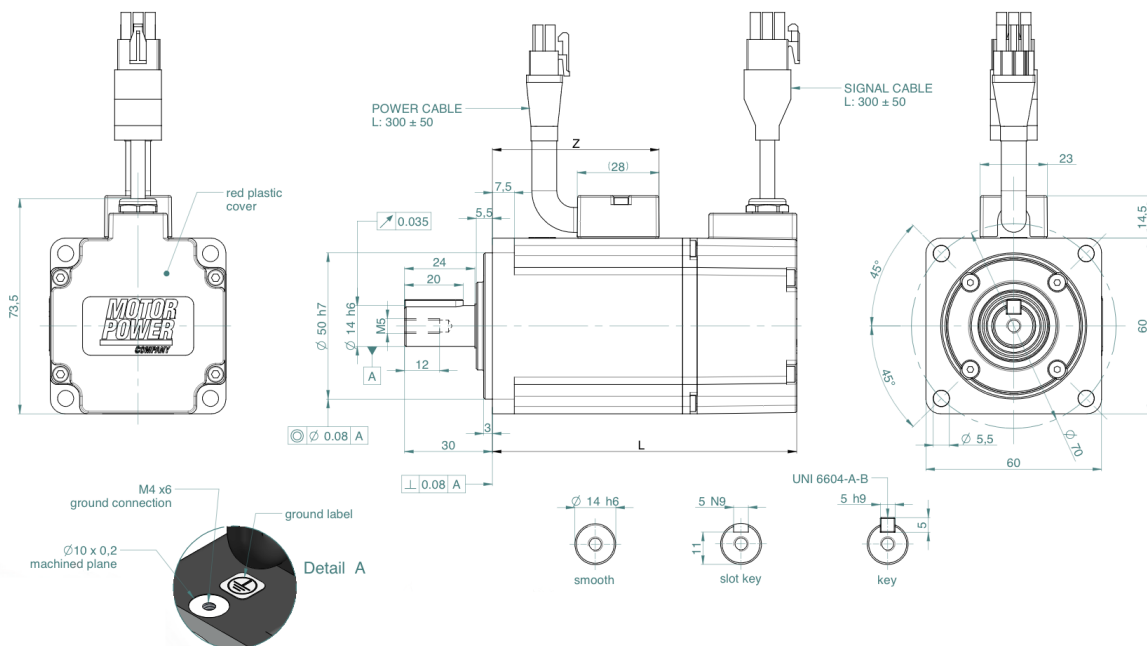

C2 connection

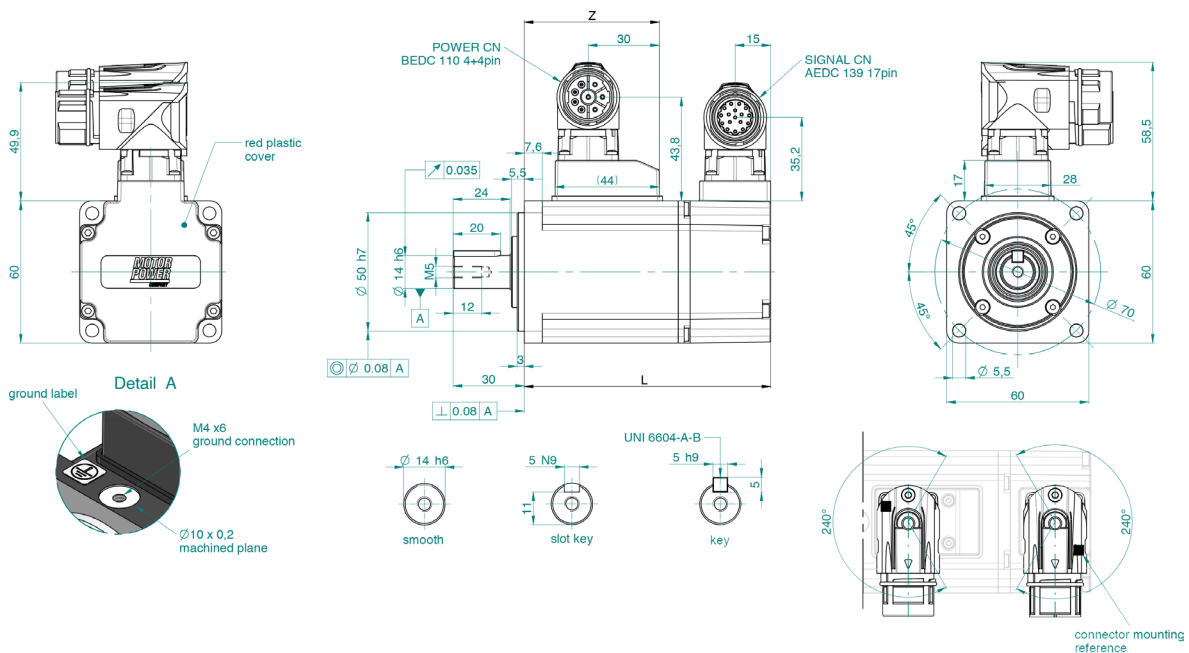

TETRA COMPACT-E 80

230 Vac RATINGS AND SPECIFICATIONS

TIME RATING	Continuous	AMBIENT TEMPERATURE	-20 ... + 40 °C
INSULATION CLASS	F	RELATIVE HUMIDITY	5 ... 85% (non-condensing)
ENCLOSURE	Totally enclosed. Self-cooled	POLES	8
PROTECTION CLASS	IP 54 Standard IP 65 with shaft sealing	CERTIFICATION	UL 1004, CSA, CE and Rohs approved Reach compliance

TC-E 80 3A D2 2

TC-E 80 3B D4 2

Continuous stall torque	M_0	Nm	1,27	2,39
Peak torque	M_{max}	Nm	3,81	7,16
Nominal working speed	nN	min ⁻¹	3000	3000
Maximum working speed	nmax	min ⁻¹	6000	6000
Nominal torque	M_n	Nm	1,27	2,39
Nominal current	I_N	A_{rms}	2,52	4,29
Nominal power	P_N	kW	0,40	0,75
Rated winding voltage	U_n	V_{ac}	230	230
Maximum winding voltage	U_{max}	V_{dc}	360	360
Maximum voltage to ground		V_{ac}	255	255
Maximum current	I_{max}	A_{rms}	7,80	13,50
Continuous stall current	I_0	A_{rms}	2,29	4,01
Voltage Constant	K_{eu-v}	V_{rms}/K_{rpm}	33,5	36
Torque Constant	k_t	Nm/ A_{rms}	0,55	0,60
Winding resistance	R_{20u-v}	Ohm	3,2	1,5
Winding inductance	L_{qu-v}	mH	12	6,6
Winding inductance	L_{du-v}	mH	11,3	6,1
Rotor inertia without holding brake	J_M	Kgcm ²	0,66	1,18
Rotor inertia with holding brake	J_M	Kgcm ²	0,71	1,23
Rotor high inertia without holding brake	J_M	Kgcm ²	-	1,53
Rotor high inertia with holding brake	J_M	Kgcm ²	-	1,58
Mass without holding brake	m	Kg	2	2,8
Mass with holding brake	m	Kg	2,8	3,6
High inertia mass without holding brake	m	Kg	-	2,9
High inertia mass with holding brake	m	Kg	-	3,7
Thermal time constant	Tth	min	25	28
Maximum radial shaft load		N	332	332
Maximum axial shaft load		N	115	115

Rated output with 250x250x12mm aluminum heat sink flange coupling - Ambient temperature 40°C - Derating must be considered if the oil seal is applied

SEE IT BEFORE IT HAPPENS

TETRA COMPACT-E 80

400 Vac RATINGS AND SPECIFICATIONS

TIME RATING	Continuous	AMBIENT TEMPERATURE	-20 ... + 40 °C
INSULATION CLASS	F	RELATIVE HUMIDITY	5 ... 85% (non-condensing)
ENCLOSURE	Totally enclosed. Self-cooled	POLES	8
PROTECTION CLASS	IP 54 Standard IP 65 with shaft sealing	CERTIFICATION	UL 1004, CSA, CE and Rohs approved Reach compliance

TC-E 80 3A D2 4

TC-E 80 3B F3 4

Continuous stall torque	M_0	Nm	1,27	2,39
Peak torque	M_{max}	Nm	3,81	7,16
Nominal working speed	nN	min ⁻¹	3000	3000
Maximum working speed	nmax	min ⁻¹	6000	6000
Nominal torque	M_n	Nm	1,27	2,39
Nominal current	I_N	A_{rms}	2,52	2,81
Nominal power	P_N	kW	0,40	0,75
Rated winding voltage	U_n	V_{ac}	400	400
Maximum winding voltage	U_{max}	V_{dc}	650	650
Maximum voltage to ground		V_{ac}	265	265
Maximum current	I_{max}	A_{rms}	7,80	8,66
Continuous stall current	I_0	A_{rms}	2,29	2,63
Voltage Constant	K_{eu-v}	V_{rms}/K_{rpm}	33,5	55
Torque Constant	k_t	Nm/ A_{rms}	0,55	0,91
Winding resistance	R_{20u-v}	Ohm	3,2	3,5
Winding inductance	L_{qu-v}	mH	12	15,4
Winding inductance	L_{du-v}	mH	11,3	14,2
Rotor inertia without holding brake	J_M	Kgcm ²	0,66	1,18
Rotor inertia with holding brake	J_M	Kgcm ²	0,71	1,23
Rotor high inertia without holding brake	J_M	Kgcm ²	-	1,53
Rotor high inertia with holding brake	J_M	Kgcm ²	-	1,58
Mass without holding brake	m	Kg	2	2,8
Mass with holding brake	m	Kg	2,8	3,6
High inertia mass without holding brake	m	Kg	-	2,9
High inertia mass with holding brake	m	Kg	-	3,7
Thermal time constant	Tth	min	25	28
Maximum radial shaft load		N	332	332
Maximum axial shaft load		N	115	115

Rated output with 250x250x12mm aluminum heat sink flange coupling - Ambient temperature 40°C - Derating must be considered if the oil seal is applied

SEE IT BEFORE IT HAPPENS

**MOTOR
POWER**
COMPANY

TETRA COMPACT-E 80

230-400 Vac TORQUE AND SPEED CHARTS

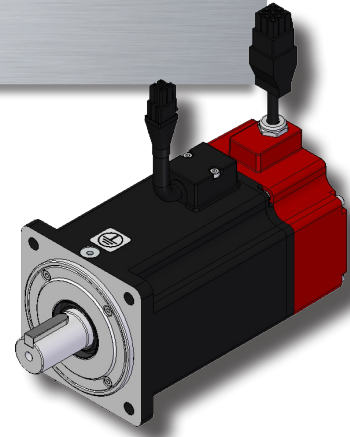

TETRA COMPACT-E 80 3A D2 2

TETRA COMPACT-E 80 3B D4 2

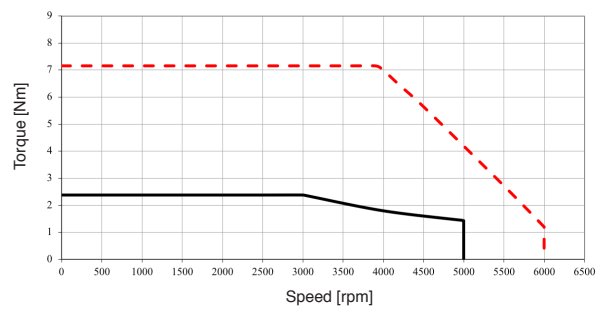
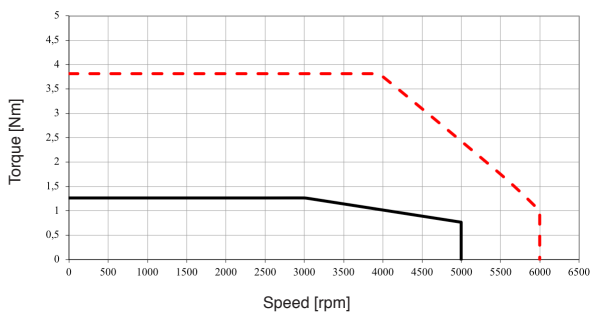

TETRA COMPACT-E 80 3A D2 4

TETRA COMPACT-E 80 3B F3 4

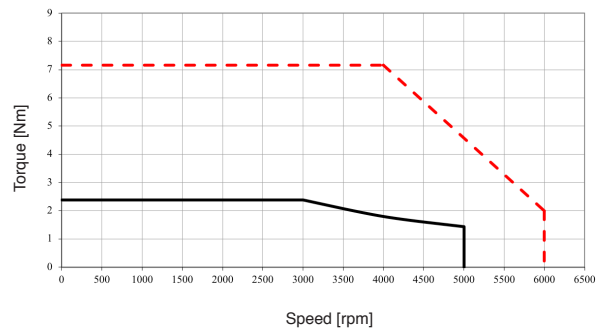
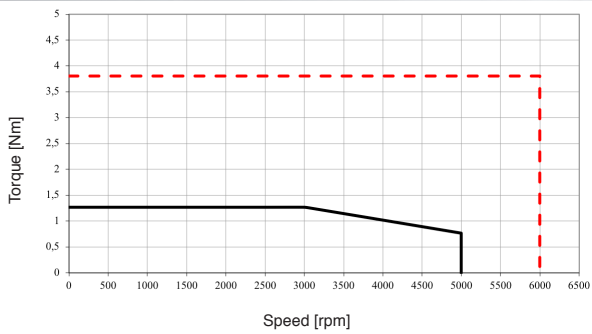

Continuous torque
 Peak torque

SEE IT BEFORE IT HAPPENS



TETRA COMPACT-E 80 DIMENSIONS

TC-E 80 3A TC-E 80 3B

L Without Brake with feedback A2	mm	112	138
L With Brake with feedback A2	mm	152	178
L Without Brake with feedback A1	mm	122	148
L With Brake with feedback A1	mm	162	188
Z Without Brake	mm	68	93
Z With Brake	mm	68	93
D	mm	14	19
A	mm	30	35
C	mm	24,5	29,5
M	mm	M5	M6
N	mm	12	16
F	mm	20	25
W	mm	5	6
T	mm	5	6
V	mm	5	6
R	mm	11	15,5

D0 connection

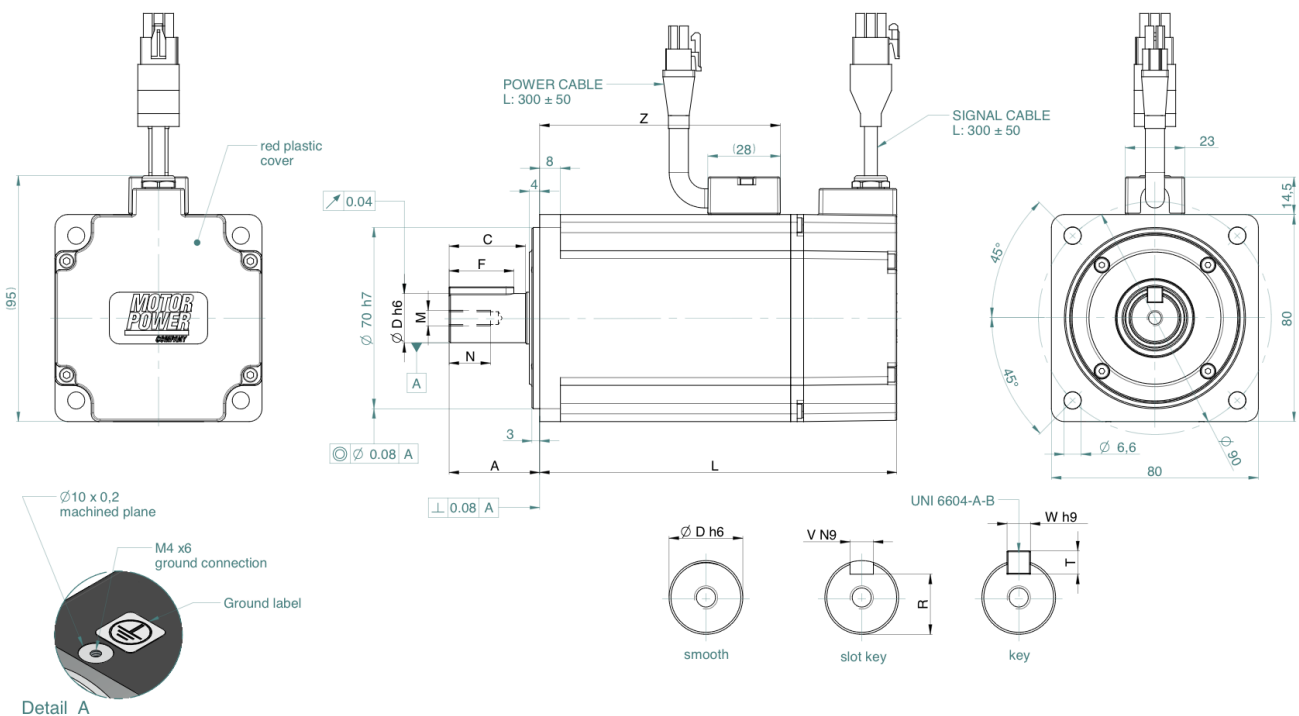

TETRA COMPACT-E 100

230 Vac RATINGS AND SPECIFICATIONS

TIME RATING
INSULATION CLASS
ENCLOSURE
PROTECTION CLASS

Continuous
F
Totally enclosed. Self-cooled
IP 54 Standard
IP 65 with shaft sealing

AMBIENT TEMPERATURE
RELATIVE HUMIDITY
POLES
CERTIFICATION

-20 ... + 40 °C
5 ... 85% (non-condensing)
10
UL 1004, CSA, CE and Rohs approved
Reach compliance

TC-E 100 4A D1 2

TC-E 100 4B D5 2

Continuous stall torque	M_0	Nm	3,18	6,37
Peak torque	M_{max}	Nm	9,54	19,11
Nominal working speed	nN	min ⁻¹	3000	3000
Maximum working speed	nmax	min ⁻¹	6000	6000
Nominal torque	M_n	Nm	3,18	6,37
Nominal current	I_N	A_{rms}	6,64	10,27
Nominal power	P_N	kW	1,00	2,00
Rated winding voltage	U_n	V_{ac}	230	230
Maximum winding voltage	U_{max}	V_{dc}	360	360
Maximum voltage to ground		V_{ac}	255	255
Maximum current	I_{max}	A_{rms}	20,0	35,0
Continuous stall current	I_0	A_{rms}	5,83	9,87
Voltage Constant	K_{eu-v}	V_{rms}/K_{rpm}	33	39
Torque Constant	k_t	Nm/ A_{rms}	0,55	0,65
Winding resistance	R_{20u-v}	Ohm	0,67	0,36
Winding inductance	L_{qu-v}	mH	4,3	2,6
Winding inductance	L_{du-v}	mH	4,2	2,59
Rotor inertia without holding brake	J_M	Kgcm ²	2,39	4,27
Rotor inertia with holding brake	J_M	Kgcm ²	2,44	4,34
Mass without holding brake	m	Kg	4,6	6,7
Mass with holding brake	m	Kg	5,1	7,2
Thermal time constant	Tth	min	28	30
Maximum radial shaft load		N	570	570
Maximum axial shaft load		N	155	155

Rated output with 300x300x20mm steel heat sink flange coupling - Ambient temperature 40°C - Derating must be considered if the oil seal is applied

SEE IT BEFORE IT HAPPENS

**MOTOR
POWER**
COMPANY

TETRA COMPACT-E 100

400 Vac RATINGS AND SPECIFICATIONS

TIME RATING
INSULATION CLASS
ENCLOSURE
PROTECTION CLASS

Continuous
F
Totally enclosed. Self-cooled
IP 54 Standard
IP 65 with shaft sealing

AMBIENT TEMPERATURE
RELATIVE HUMIDITY
POLES
CERTIFICATION

-20 ... + 40 °C
5 ... 85% (non-condensing)
10
UL 1004, CSA, CE and Rohs approved
Reach compliance

TC-E 100 4A D6 4

TC-E 100 4B H3 4

Continuous stall torque	M_0	Nm	3,18	6,37
Peak torque	M_{max}	Nm	9,54	19,11
Nominal working speed	nN	min ⁻¹	3000	3000
Maximum working speed	nmax	min ⁻¹	6000	5500
Nominal torque	M_n	Nm	3,18	6,37
Nominal current	I_N	A_{rms}	5,77	5,56
Nominal power	P_N	kW	1,00	2,00
Rated winding voltage	U_n	V_{ac}	400	400
Maximum winding voltage	U_{max}	V_{dc}	650	650
Maximum voltage to ground		V_{ac}	265	265
Maximum current	I_{max}	A_{rms}	16,40	17,65
Continuous stall current	I_0	A_{rms}	5,06	5,35
Voltage Constant	K_{eu-v}	V_{rms}/K_{rpm}	38	72
Torque Constant	k_t	Nm/ A_{rms}	0,63	1,19
Winding resistance	R_{20u-v}	Ohm	0,89	1,23
Winding inductance	L_{qu-v}	mH	5,7	8,9
Winding inductance	L_{du-v}	mH	5,6	8,7
Rotor inertia without holding brake	J_M	Kgcm ²	2,39	4,27
Rotor inertia with holding brake	J_M	Kgcm ²	2,44	4,34
Mass without holding brake	m	Kg	4,6	6,7
Mass with holding brake	m	Kg	5,1	7,2
Thermal time constant	Tth	min	28	30
Maximum radial shaft load		N	570	570
Maximum axial shaft load		N	155	155

Rated output with 300x30x20mm steel heat sink flange coupling - Ambient temperature 40°C - Derating must be considered if the oil seal is applied

SEE IT BEFORE IT HAPPENS

**MOTOR
POWER**
COMPANY

TETRA COMPACT-E 100

230-400 Vac TORQUE AND SPEED CHARTS

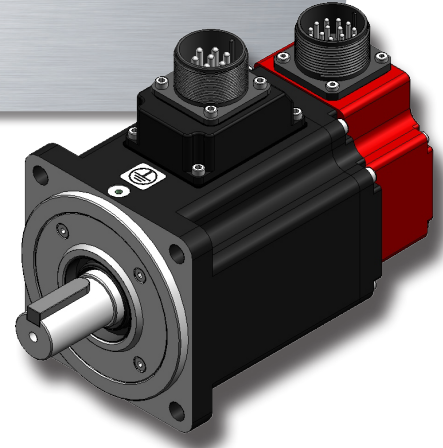

TETRA COMPACT-E 100 4A D1 2

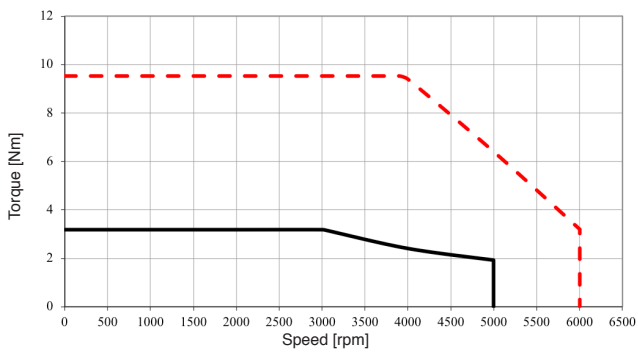

TETRA COMPACT-E 100 4B D5 2

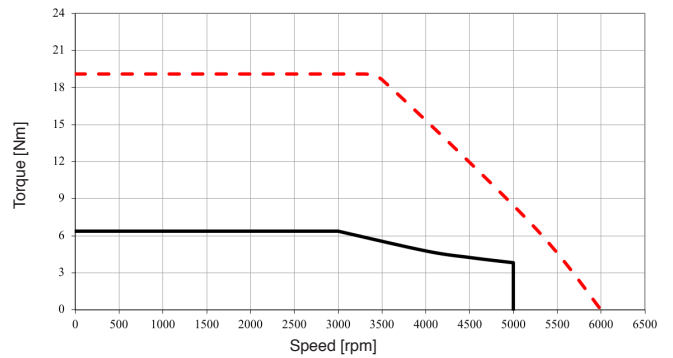

TETRA COMPACT-E 100 4A D6 4

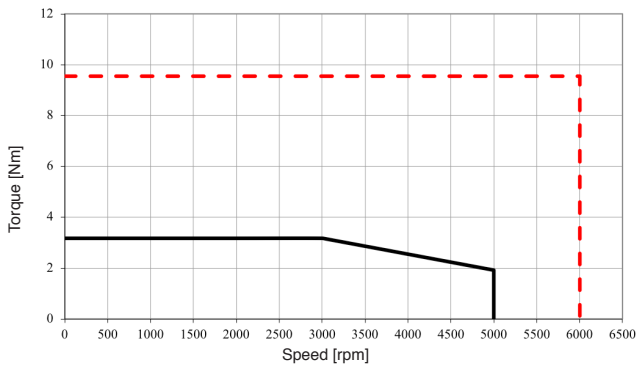

TETRA COMPACT-E 100 4B H3 4

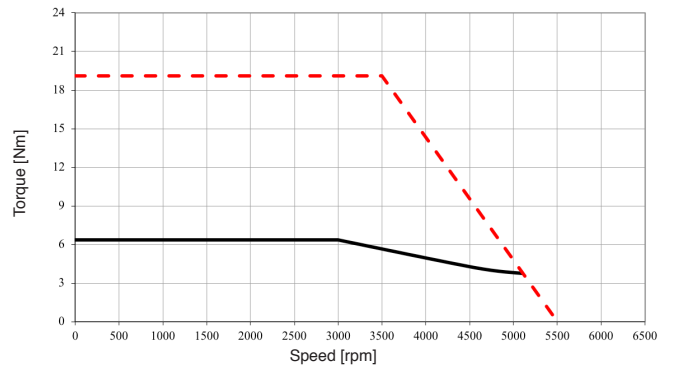

Continuous torque
 Peak torque

SEE IT BEFORE IT HAPPENS



TETRA COMPACT-E 100 DIMENSIONS

TC-E 100 4A TC-E 100 4B

L Without Brake with feedback A2	mm	153,5	198,5
L With Brake with feedback A2	mm	180,5	225,5
L Without Brake with feedback A1	mm	165,5	210,5
L With Brake with feedback A1	mm	192,5	237,5
Z Without Brake	mm	96	141
Z With Brake	mm	96	141

C2 connection

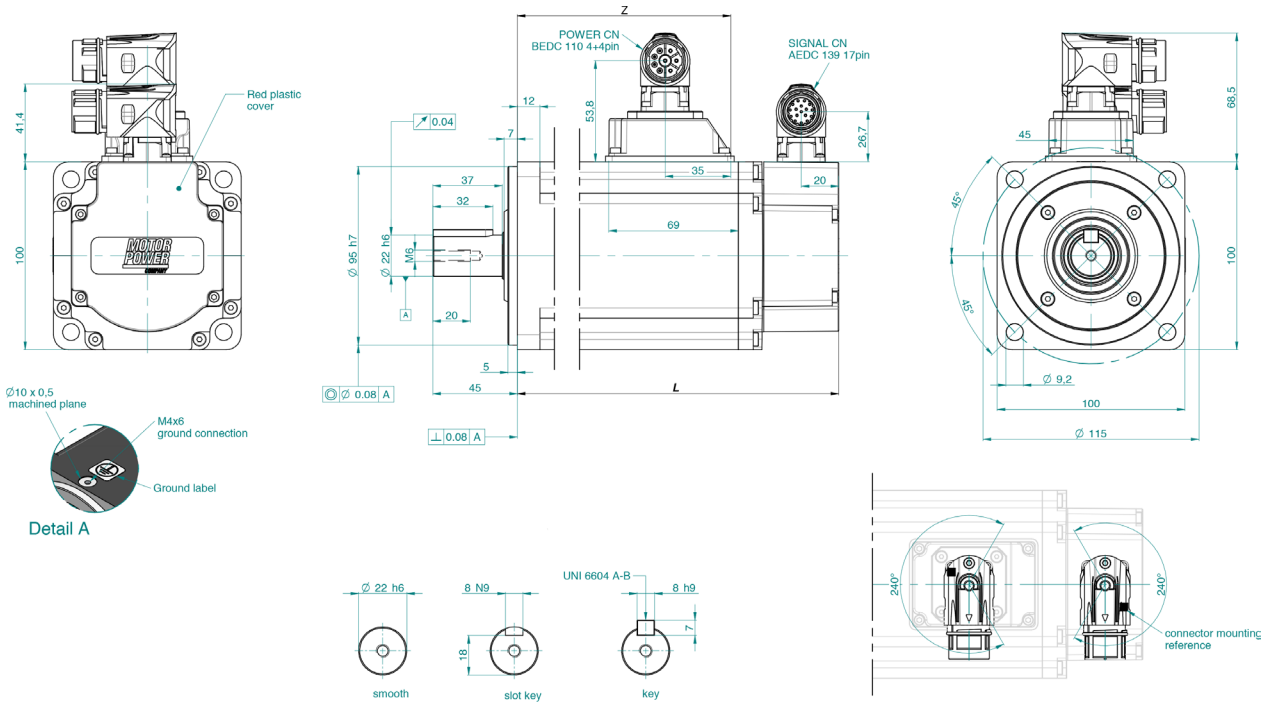

C3 connection

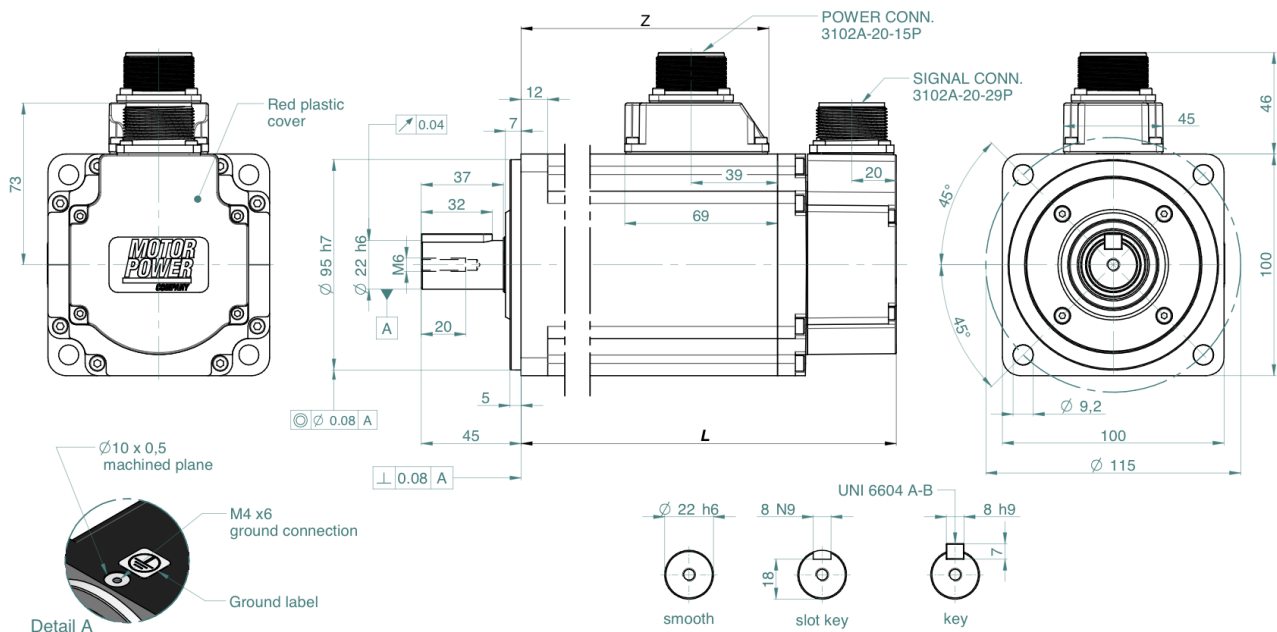

TETRA COMPACT-E 130

230 Vac RATINGS AND SPECIFICATIONS.1

TIME RATING	Continuous	AMBIENT TEMPERATURE	-20 ... + 40 °C
INSULATION CLASS	F	RELATIVE HUMIDITY	5 ... 85% (non-condensing)
ENCLOSURE	Totally enclosed. Self-cooled	POLES	10
PROTECTION CLASS	IP 54 Standard IP 65 with shaft sealing	CERTIFICATION	UL 1004, CSA, CE and Rohs approved Reach compliance

TC-E 130 5A F1 2 TC-E 130 5B L1 2 TC-E 130 5C F1 2 TC-E 130 5D F4 2

Continuous stall torque	M_0	Nm	2,39	2,86	4,77	5,39
Peak torque	M_{max}	Nm	7,16	8,59	14,3	13,8
Nominal working speed	n_N	min^{-1}	2000	1000	2000	1500
Maximum working speed	n_{max}	min^{-1}	3000	2000	3000	3000
Nominal torque	M_n	Nm	2,39	2,86	4,77	5,39
Nominal current	I_N	A_{rms}	3,24	2,09	6,29	6,29
Nominal power	P_N	kW	0,50	0,30	1,00	0,85
Rated winding voltage	U_n	V_{ac}	230	230	230	230
Maximum winding voltage	U_{max}	V_{dc}	360	360	360	360
Maximum voltage to ground		V_{ac}	255	255	255	255
Maximum current	I_{max}	A_{rms}	9,50	6,00	20,00	15,00
Continuous stall current	I_0	A_{rms}	2,89	1,88	5,77	5,62
Voltage Constant	K_{eu-v}	V_{rms}/K_{rpm}	50	92	50	58
Torque Constant	k_t	Nm/A_{rms}	0,83	1,52	0,83	0,96
Winding resistance	R_{20u-v}	Ohm	0,74	2,08	0,74	0,42
Winding inductance	L_{qu-v}	mH	7,84	26,25	7,84	4,70
Winding inductance	L_{du-v}	mH	7,14	23,91	7,14	4,30
Rotor inertia without holding brake	J_M	Kgcm^2	6,62	6,62	6,62	13,49
Rotor inertia with holding brake	J_M	Kgcm^2	6,9	6,9	6,9	14,09
Rotor high inertia without holding brake	J_M	Kgcm^2	-	-	8,4	-
Rotor high inertia with holding brake	J_M	Kgcm^2	-	-	8,53	-
Mass without holding brake	m	Kg	7	7	7	9,6
Mass with holding brake	m	Kg	8,2	8,2	8,2	10,9
High inertia mass without holding brake	m	Kg	-	-	7,1	-
High inertia mass with holding brake	m	Kg	-	-	8,3	-
Thermal time constant	T_{th}	min	30	30	33	35
Maximum radial shaft load		N	670	670	670	670
Maximum axial shaft load		N	200	200	200	200

Rated output with 400x400x20mm steel heat sink flange coupling - Ambient temperature 40°C - Derating must be considered if the oil seal is applied

SEE IT BEFORE IT HAPPENS

**MOTOR
POWER**
COMPANY

TETRA COMPACT-E 130

230 Vac RATINGS AND SPECIFICATIONS.2

TIME RATING	Continuous	AMBIENT TEMPERATURE	-20 ... + 40 °C
INSULATION CLASS	F	RELATIVE HUMIDITY	5 ... 85% (non-condensing)
ENCLOSURE	Totally enclosed. Self-cooled	POLES	10
PROTECTION CLASS	IP 54 Standard IP 65 with shaft sealing	CERTIFICATION	UL 1004, CSA, CE and Rohs approved Reach compliance

TC-E 130 5E L1 2

TC-E 130 5F L1 2

TC-E 130 5G H1 2

TC-E 130 5H F4 2

			TC-E 130 5E L1 2	TC-E 130 5F L1 2	TC-E 130 5G H1 2	TC-E 130 5H F4 2
Continuous stall torque	M_0	Nm	5,73	8,59	7,16	9,55
Peak torque	M_{max}	Nm	17,19	25,77	21,48	28,65
Nominal working speed	nN	min ⁻¹	1000	1000	2000	2000
Maximum working speed	nmax	min ⁻¹	2000	2000	3000	3000
Nominal torque	M_n	Nm	5,73	8,59	7,16	9,55
Nominal current	I_N	A_{rms}	4,10	6,15	6,74	11,25
Nominal power	P_N	kW	0,60	0,90	1,50	2,00
Rated winding voltage	U_n	V_{ac}	230	230	230	230
Maximum winding voltage	U_{max}	V_{dc}	360	360	360	360
Maximum voltage to ground		V_{ac}	255	255	255	255
Maximum current	I_{max}	A_{rms}	13,50	20,00	21,00	33,00
Continuous stall current	I_0	A_{rms}	3,77	5,64	6,18	9,95
Voltage Constant	K_{eu-v}	V_{rms}/K_{rpm}	92	92	70	58
Torque Constant	k_t	Nm/A_{rms}	1,52	1,52	1,16	0,96
Winding resistance	R_{20u-v}	Ohm	2,08	1,22	0,64	0,42
Winding inductance	L_{qu-v}	mH	26,25	16,4	7,20	4,70
Winding inductance	L_{du-v}	mH	23,91	14,90	6,40	4,30
Rotor inertia without holding brake	J_M	Kgcm ²	6,62	9,69	9,69	13,49
Rotor inertia with holding brake	J_M	Kgcm ²	6,9	9,99	9,99	14,09
Mass without holding brake	m	Kg	7	7,6	7,6	9,7
Mass with holding brake	m	Kg	8,2	8,8	8,8	11
Thermal time constant	Tth	min	33	35	35	35
Maximum radial shaft load		N	670	670	670	670
Maximum axial shaft load		N	200	200	200	200

Rated output with 400x400x20mm steel heat sink flange coupling - Ambient temperature 40°C - Derating must be considered if the oil seal is applied

TETRA COMPACT-E 130

400 Vac RATINGS AND SPECIFICATIONS.1

TIME RATING	Continuous	AMBIENT TEMPERATURE	-20 ... + 40 °C
INSULATION CLASS	F	RELATIVE HUMIDITY	5 ... 85% (non-condensing)
ENCLOSURE	Totally enclosed. Self-cooled	POLES	10
PROTECTION CLASS	IP 54 Standard IP 65 with shaft sealing	CERTIFICATION	UL 1004, CSA, CE and Rohs approved Reach compliance

TC-E 130 5A F1 4 TC-E 130 5B L1 4 TC-E 130 5C F1 4 TC-E 130 5D F4 4 TC-E 130 5D L3 4

			TC-E 130 5A F1 4	TC-E 130 5B L1 4	TC-E 130 5C F1 4	TC-E 130 5D F4 4	TC-E 130 5D L3 4
Continuous stall torque	M_0	Nm	2,39	2,86	4,77	5,39	5,39
Peak torque	M_{max}	Nm	7,16	8,59	14,3	13,8	13,8
Nominal working speed	n_N	min ⁻¹	2000	1000	2000	1500	1500
Maximum working speed	n_{max}	min ⁻¹	3000	2000	4000	3000	3000
Nominal torque	M_n	Nm	2,39	2,86	4,77	5,39	5,39
Nominal current	I_N	A _{rms}	3,24	2,09	6,29	6,29	2,95
Nominal power	P_N	kW	0,50	0,30	1,00	0,85	0,85
Rated winding voltage	U_n	V _{ac}	400	400	400	400	400
Maximum winding voltage	U_{max}	V _{dc}	650	650	650	650	650
Maximum voltage to ground		V _{ac}	265	265	265	265	265
Maximum current	I_{max}	A _{rms}	9,50	6,00	20,00	15,00	7,00
Continuous stall current	I_0	A _{rms}	2,89	1,88	5,77	5,62	2,63
Voltage Constant	K_{eu-v}	V _{rms} /K _{rpm}	50	92	50	58	129
Torque Constant	k_t	Nm/A _{rms}	0,83	1,52	0,83	0,96	2,13
Winding resistance	R_{20u-v}	Ohm	0,74	2,08	0,74	0,42	1,78
Winding inductance	L_{qu-v}	mH	7,84	26,25	7,84	4,70	21,19
Winding inductance	L_{du-v}	mH	7,14	23,91	7,14	4,30	19,25
Rotor inertia without holding brake	J_M	Kgcm ²	6,62	6,62	6,62	13,49	13,49
Rotor inertia with holding brake	J_M	Kgcm ²	6,9	6,9	6,9	14,09	14,09
Rotor high inertia without holding brake	J_M	Kgcm ²	-	-	8,4	-	-
Rotor high inertia with holding brake	J_M	Kgcm ²			8,53		
Mass without holding brake	m	Kg	7	7	7	9,6	9,6
Mass with holding brake	m	Kg	8,2	8,2	8,2	10,9	10,9
High inertia mass without holding brake	m	Kg	-	-	7,1	-	-
High inertia mass with holding brake	m	Kg	-	-	8,2	-	-
Thermal time constant	T_{th}	min	30	30	33	35	35
Maximum radial shaft load		N	670	670	670	670	670
Maximum axial shaft load		N	200	200	200	200	200

Rated output with 400x400x20mm steel heat sink flange coupling - Ambient temperature 40°C - Derating must be considered if the oil seal is applied

SEE IT BEFORE IT HAPPENS

**MOTOR
POWER**
COMPANY

TETRA COMPACT-E 130

400 Vac RATINGS AND SPECIFICATIONS.2

TIME RATING	Continuous	AMBIENT TEMPERATURE	-20 ... + 40 °C
INSULATION CLASS	F	RELATIVE HUMIDITY	5 ... 85% (non-condensing)
ENCLOSURE	Totally enclosed. Self-cooled	POLES	10
PROTECTION CLASS	IP 54 Standard IP 65 with shaft sealing	CERTIFICATION	UL 1004, CSA, CE and Rohs approved Reach compliance

TC-E 130 5E L1 4 TC-E 130 5F L1 4 TC-E 130 5G H1 4 TC-E 130 5H F4 4

Continuous stall torque	M_0	Nm	5,73	8,59	7,16	9,55
Peak torque	M_{max}	Nm	17,19	25,77	21,48	28,65
Nominal working speed	nN	min ⁻¹	1000	1000	2000	2000
Maximum working speed	nmax	min ⁻¹	2000	2000	3000	5000
Nominal torque	M_n	Nm	5,73	8,59	7,16	9,55
Nominal current	I_N	A_{rms}	4,10	6,15	6,74	11,25
Nominal power	P_N	kW	0,60	0,90	1,50	2,00
Rated winding voltage	U_n	V_{ac}	400	400	400	400
Maximum winding voltage	U_{max}	V_{dc}	650	650	650	650
Maximum voltage to ground		V_{ac}	265	265	265	265
Maximum current	I_{max}	A_{rms}	13,50	20,00	21,00	33,00
Continuous stall current	I_0	A_{rms}	3,77	5,64	6,18	9,95
Voltage Constant	K_{eu-v}	V_{rms}/K_{rpm}	92	92	70	58
Torque Constant	k_t	Nm/A_{rms}	1,52	1,52	1,16	0,96
Winding resistance	R_{20u-v}	Ohm	2,08	1,22	0,64	0,42
Winding inductance	L_{qu-v}	mH	26,25	16,4	7,2	4,70
Winding inductance	L_{du-v}	mH	23,91	14,90	6,40	4,30
Rotor inertia without holding brake	J_M	Kgcm ²	6,62	9,69	9,69	13,49
Rotor inertia with holding brake	J_M	Kgcm ²	6,9	9,99	9,99	14,09
Mass without holding brake	m	Kg	7,0	7,6	7,6	9,7
Mass with holding brake	m	Kg	8,2	8,8	8,8	11
Thermal time constant	Tth	min	33	35	35	35
Maximum radial shaft load		N	670	670	670	670
Maximum axial shaft load		N	200	200	200	200

Rated output with 400x400x20mm steel heat sink flange coupling - Ambient temperature 40°C - Derating must be considered if the oil seal is applied

SEE IT BEFORE IT HAPPENS

TETRA COMPACT-E 130

230 Vac TORQUE AND SPEED CHARTS .1

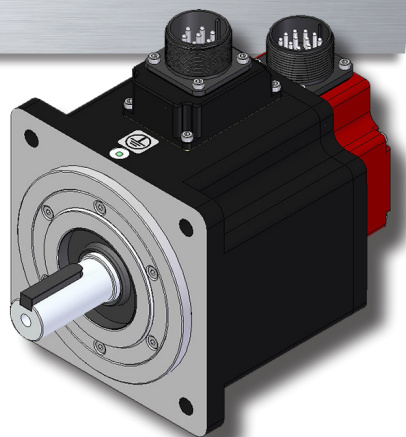

TETRA COMPACT-E 130 5A F1 2

TETRA COMPACT-E 130 5B L1 2

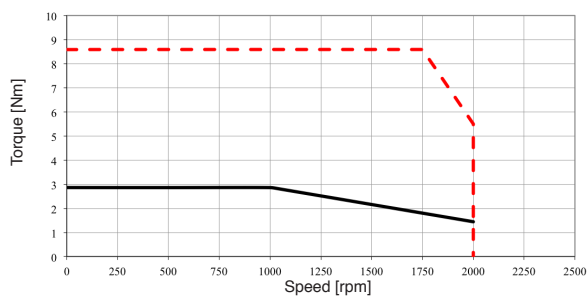
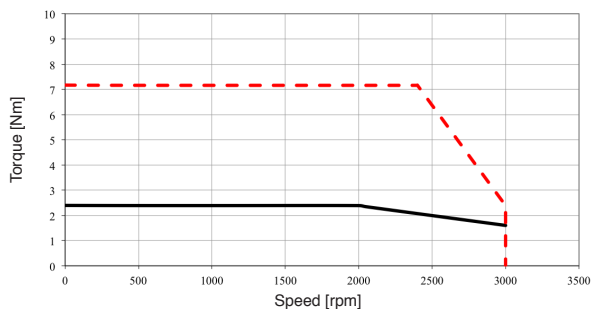

TETRA COMPACT-E 130 5C F1 2

TETRA COMPACT-E 130 5D F4 2

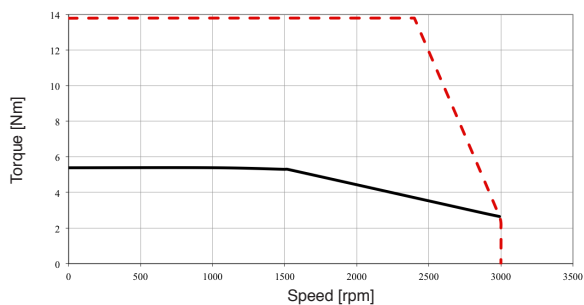
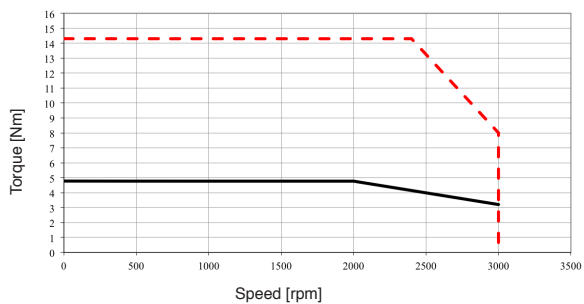

Continuous torque
 Peak torque

SEE IT BEFORE IT HAPPENS



TETRA COMPACT-E 130

230 Vac TORQUE AND SPEED CHARTS .2

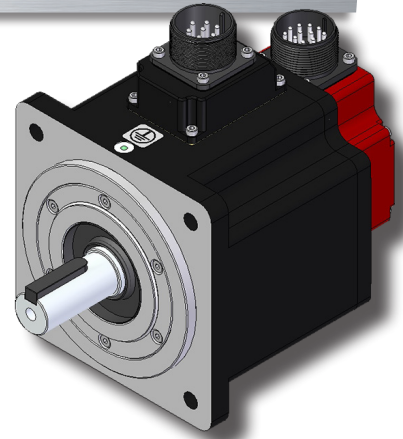

TETRA COMPACT-E 130 5E L1 2

TETRA COMPACT-E 130 5F L1 2

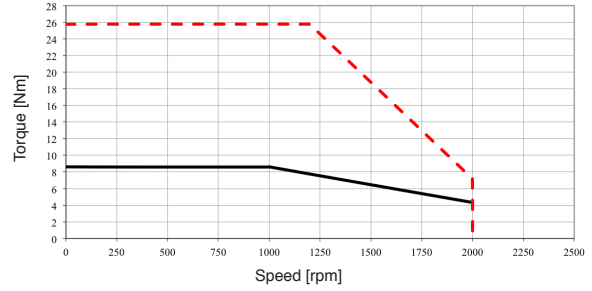
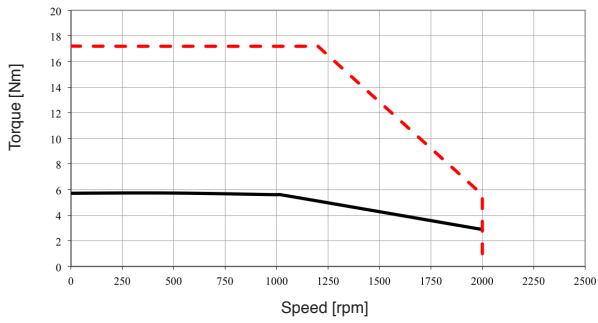

TETRA COMPACT-E 130 5G H1 2

TETRA COMPACT-E 130 5H F4 2

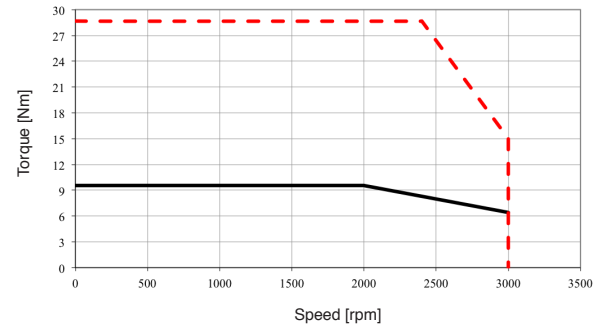
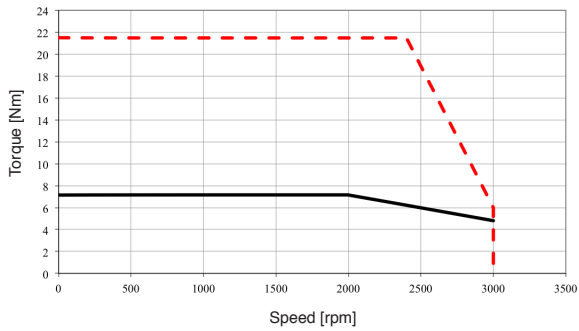

Continuous torque
 Peak torque

SEE IT BEFORE IT HAPPENS



TETRA COMPACT-E 130

400 Vac TORQUE AND SPEED CHARTS .1

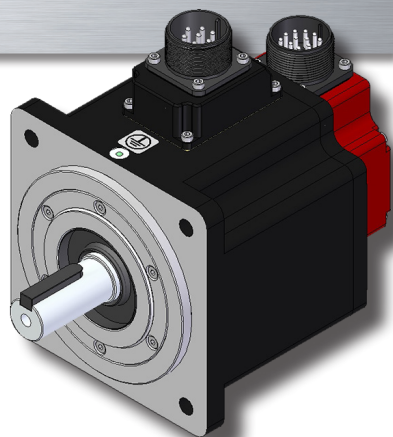

TETRA COMPACT-E 130 5A F1 4

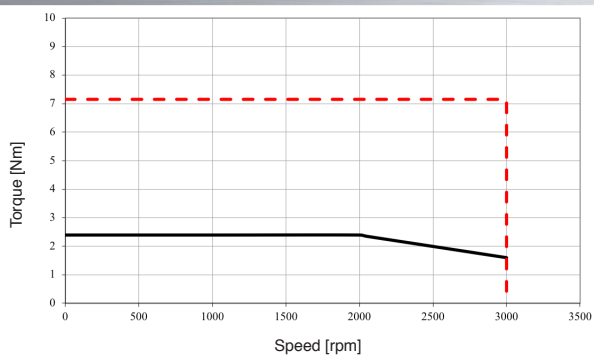

TETRA COMPACT-E 130 5B L1 4

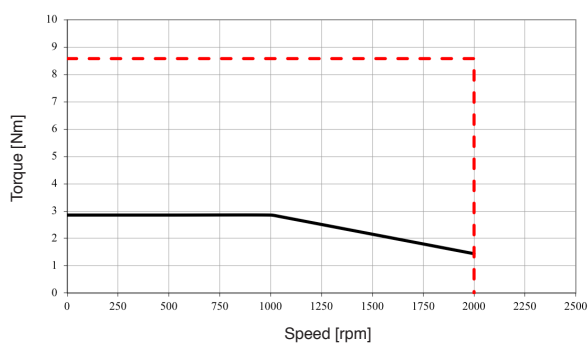

TETRA COMPACT-E 130 5C F1 4

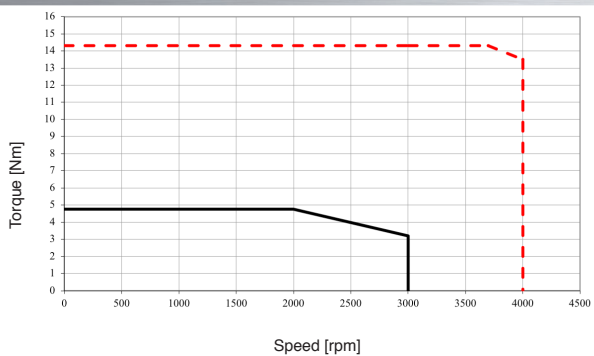

TETRA COMPACT-E 130 5D F4 4

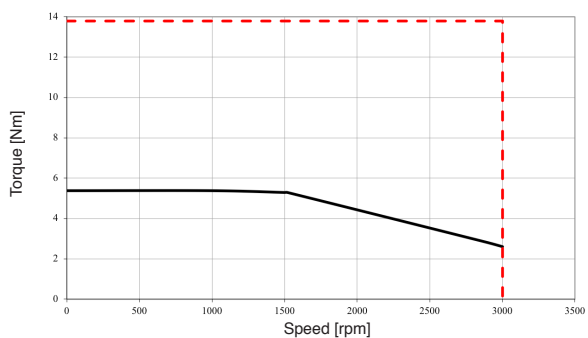

Continuous torque
 Peak torque

SEE IT BEFORE IT HAPPENS



TETRA COMPACT-E 130

400 Vac TORQUE AND SPEED CHARTS .2

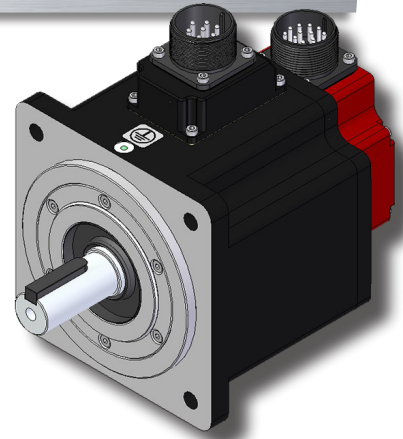

TETRA COMPACT-E 130 5E L1 4

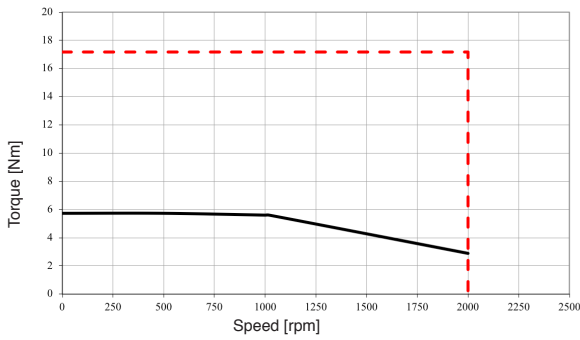

TETRA COMPACT-E 130 5F L1 4

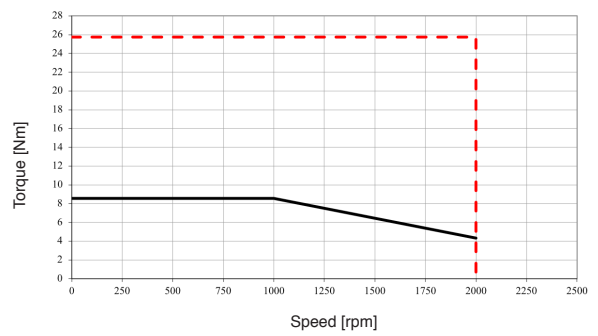

TETRA COMPACT-E 130 5G H1 4

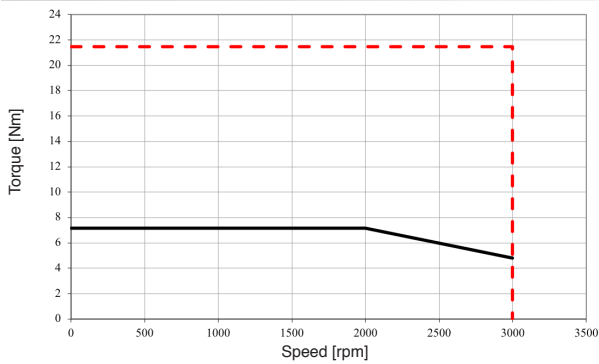

TETRA COMPACT-E 130 5H F4 4

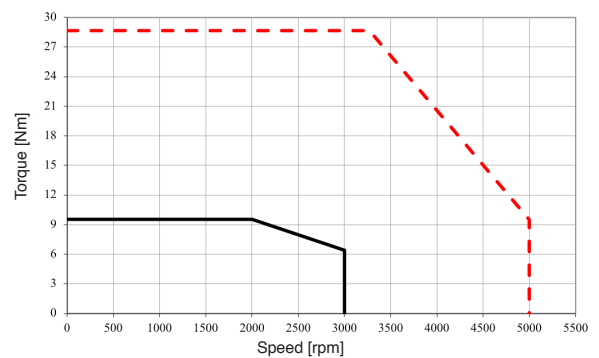

Continuous torque
 Peak torque

SEE IT BEFORE IT HAPPENS



TETRA COMPACT-E 130 DIMENSIONS

C3 connection

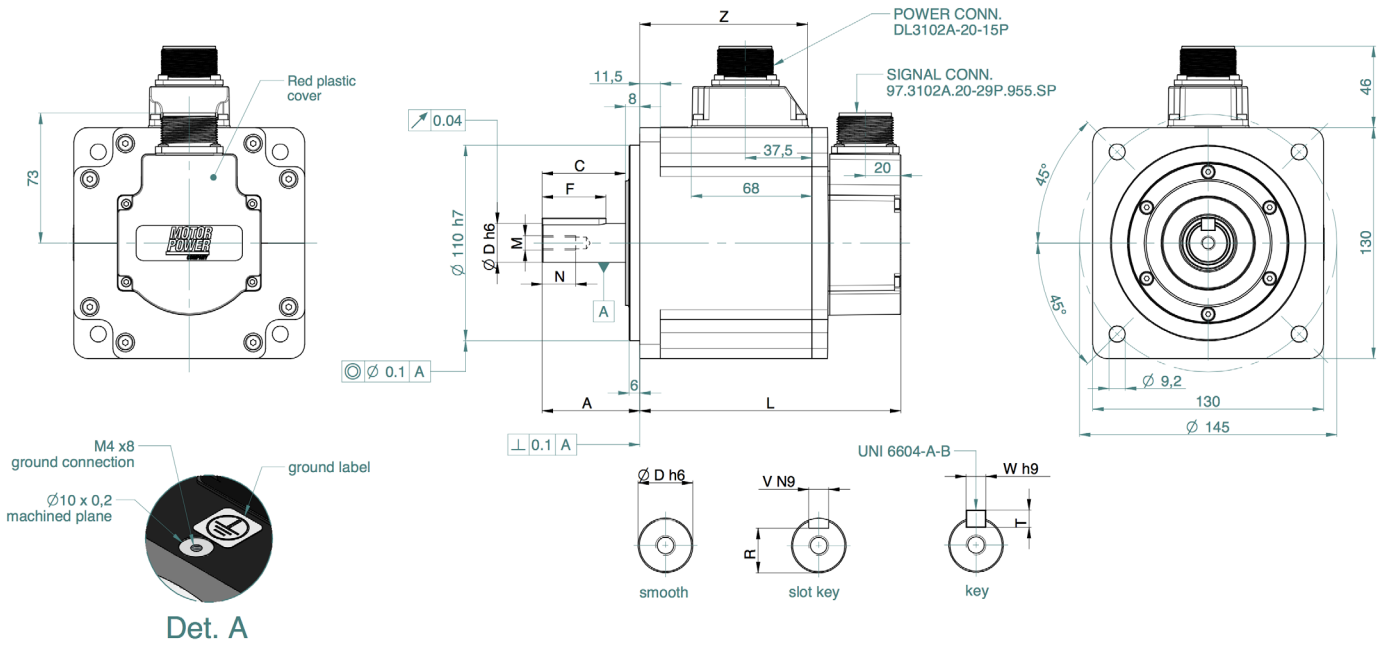

SEE IT BEFORE IT HAPPENS

TETRA COMPACT-E 180

230 Vac RATINGS AND SPECIFICATIONS.1

TIME RATING	Continuous	AMBIENT TEMPERATURE	-20 ... + 40 °C
INSULATION CLASS	F	RELATIVE HUMIDITY	5 ... 85% (non-condensing)
ENCLOSURE	Totally enclosed. Self-cooled	POLES	10
PROTECTION CLASS	IP 54 Standard IP 65 with shaft sealing	CERTIFICATION	UL 1004, CSA, CE and Rohs approved Reach compliance

TC-E 180 6A G2 2 TC-E 180 6B F2 2 TC-E 180 6C H1 2 TC-E 180 6D E2 2

Continuous stall torque	M_0	Nm	9,55	14,32	19,1	16,7
Peak torque	M_{max}	Nm	28,65	42,97	57,29	50,3
Nominal working speed	nN	min ⁻¹	2000	2000	1500	2000
Maximum working speed	nmax	min ⁻¹	3000	3000	3000	3000
Nominal torque	M_n	Nm	9,55	14,32	19,1	16,7
Nominal current	I_N	A_{rms}	9,6	18,8	18,8	19,3
Nominal power	P_N	kW	2,00	3,00	3,00	3,50
Rated winding voltage	U_n	V_{ac}	230	230	230	230
Maximum winding voltage	U_{max}	V_{dc}	360	360	360	360
Maximum voltage to ground		V_{ac}	255	255	255	255
Maximum current	I_{max}	A_{rms}	35,5	56,0	61,0	61,0
Continuous stall current	I_0	A_{rms}	8,75	16,33	16,49	16,83
Voltage Constant	K_{eu-v}	V_{rms}/K_{rpm}	66	53	70	60
Torque Constant	k_t	Nm/A_{rms}	1,09	0,88	1,16	0,99
Winding resistance	R_{20u-v}	Ohm	0,572	0,168	0,234	0,168
Winding inductance	L_{qu-v}	mH	6,70	2,88	3,78	2,80
Winding inductance	L_{du-v}	mH	6,10	2,71	3,45	2,57
Rotor inertia without holding brake	J_M	Kgcm ²	26,49	53,55	53,55	53,55
Rotor inertia with holding brake	J_M	Kgcm ²	26,99	54,09	54,09	54,09
Rotor high inertia without holding brake	J_M	Kgcm ²	34,67	-	-	-
Rotor high inertia with holding brake	J_M	Kgcm ²	35,12	-	-	-
Mass without holding brake	m	Kg	13	18,5	18,5	18,5
Mass with holding brake	m	Kg	18	23	23	23
Mass without holding brake	m	Kg	14,3	-	-	-
Mass with holding brake	m	Kg	19,3	-	-	-
Thermal time constant	Tth	min	35	38	38	38
Maximum radial shaft load		N	1200	1200	1200	1200
Maximum axial shaft load		N	497	497	497	497

Rated output with 550x550x20mm steel heat sink flange coupling - Ambient temperature 40°C - Derating must be considered if the oil seal is applied

SEE IT BEFORE IT HAPPENS

**MOTOR
POWER**
COMPANY

TETRA COMPACT-E 180

230 Vac RATINGS AND SPECIFICATIONS.2

TIME RATING	Continuous	AMBIENT TEMPERATURE	-20 ... + 40 °C
INSULATION CLASS	F	RELATIVE HUMIDITY	5 ... 85% (non-condensing)
ENCLOSURE	Totally enclosed. Self-cooled	POLES	10
PROTECTION CLASS	IP 54 Standard IP 65 with shaft sealing	CERTIFICATION	UL 1004, CSA, CE and RoHS approved Reach compliance

TC-E 180 6E G1 2

TC-E 180 6F G5 2

TC-E 180 6G G4 2

Continuous stall torque	M_0	Nm	28,65	35	47,75
Peak torque	M_{max}	Nm	71,62	87,53	119,37
Nominal working speed	nN	min ⁻¹	1500	1500	1500
Maximum working speed	nmax	min ⁻¹	2500	2600	2700
Nominal torque	M_n	Nm	28,65	35	47,75
Nominal current	I_N	A_{rms}	22,8	28,8	41,5
Nominal power	P_N	kW	4,50	5,50	7,5 (*)
Rated winding voltage	U_n	V_{ac}	230	230	230
Maximum winding voltage	U_{max}	V_{dc}	360	360	360
Maximum voltage to ground		V_{ac}	255	255	255
Maximum current	I_{max}	A_{rms}	61,0	74,2	106,9
Continuous stall current	I_0	A_{rms}	19,68	25,05	36,08
Voltage Constant	K_{eu-v}	V_{rms}/K_{rpm}	88	84,5	80
Torque Constant	k_t	Nm/A_{rms}	1,46	1,40	1,32
Winding resistance	R_{20u-v}	Ohm	0,199	0,104	0,062
Winding inductance	L_{qu-v}	mH	4,00	2,25	1,3
Winding inductance	L_{du-v}	mH	3,80	2,07	1,22
Rotor inertia without holding brake	J_M	Kgcm ²	73,31	103,33	142,69
Rotor inertia with holding brake	J_M	Kgcm ²	73,99	120,19	158,69
Mass without holding brake	m	Kg	23,64	32	41,7
Mass with holding brake	m	Kg	28	36,5	46,2
Thermal time constant	Tth	min	40	50	60
Maximum radial shaft load		N	1200	1200	1200
Maximum axial shaft load		N	497	497	497

Rated output with 550x550x20mm steel heat sink flange coupling - Ambient temperature 40°C - Derating must be considered if the oil seal is applied

(*) TC-E 180 6G H1 2 with nominal power 7,5 kW is UL 1004, CE and RoHS approved and Reach compliance

(*) TC-E 180 6G H1 2 with nominal power 7,0 kW is UL 1004, CSA, CE and RoHS approved and Reach compliance

(*) TC-E 180 6G H1 2 with holding brake has nominal power 7,0 kW

TETRA COMPACT-E 180

400 Vac RATINGS AND SPECIFICATIONS.1

TIME RATING	Continuous	AMBIENT TEMPERATURE	-20 ... + 40 °C
INSULATION CLASS	F	RELATIVE HUMIDITY	5 ... 85% (non-condensing)
ENCLOSURE	Totally enclosed. Self-cooled	POLES	10
PROTECTION CLASS	IP 54 Standard IP 65 with shaft sealing	CERTIFICATION	UL 1004, CSA, CE and Rohs approved Reach compliance

TC-E 180 6A G3 4 TC-E 180 6B F2 4 TC-E 180 6C H1 4 TC-E 180 6D E2 4

Continuous stall torque	M_0	Nm	9,55	14,32	19,1	16,7
Peak torque	M_{max}	Nm	28,65	42,97	57,29	50,3
Nominal working speed	nN	min ⁻¹	2000	2000	1500	2000
Maximum working speed	nmax	min ⁻¹	4000	4000	4000	4000
Nominal torque	M_n	Nm	9,55	14,32	19,1	16,7
Nominal current	I_N	A_{rms}	7,50	18,8	18,8	19,30
Nominal power	P_N	kW	2,00	3,00	3,00	3,50
Rated winding voltage	U_n	V_{ac}	400	400	400	400
Maximum winding voltage	U_{max}	V_{dc}	650	650	650	650
Maximum voltage to ground		V_{ac}	265	265	265	265
Maximum current	I_{max}	A_{rms}	23,0	56,0	61,0	61,0
Continuous stall current	I_0	A_{rms}	6,79	16,33	16,49	16,83
Voltage Constant	K_{eu-v}	V_{rms}/K_{rpm}	85	53	70	60
Torque Constant	k_t	Nm/A_{rms}	1,41	0,88	1,16	0,99
Winding resistance	R_{20u-v}	Ohm	1,156	0,168	0,234	0,168
Winding inductance	L_{qu-v}	mH	13,44	2,88	3,78	2,8
Winding inductance	L_{du-v}	mH	12,21	2,71	3,45	2,57
Rotor inertia without holding brake	J_M	Kgcm ²	26,49	53,55	53,55	53,55
Rotor inertia with holding brake	J_M	Kgcm ²	26,99	54,09	54,09	54,09
Rotor high inertia without holding brake	J_M	Kgcm ²	34,67	-	-	-
Rotor high inertia with holding brake	J_M	Kgcm ²	35,12	-	-	-
Mass without holding brake	m	Kg	13	18,5	18,5	18,5
Mass with holding brake	m	Kg	18	23	23	23
High inertia mass without holding brake	m	Kg	14,3	-	-	-
High inertia mass with holding brake	m	Kg	19,3	-	-	-
Thermal time constant	Tth	min	35	35	35	38
Maximum radial shaft load		N	1200	1200	1200	1200
Maximum axial shaft load		N	497	497	497	497

Rated output with 550x550x20 mm steel heat sink flange coupling - Ambient temperature 40°C. Derating must be considered if the oil seal is applied

SEE IT BEFORE IT HAPPENS

**MOTOR
POWER**
COMPANY

TETRA COMPACT-E 180

400 Vac RATINGS AND SPECIFICATIONS.2

TIME RATING	Continuous	AMBIENT TEMPERATURE	-20 ... + 40 °C
INSULATION CLASS	F	RELATIVE HUMIDITY	5 ... 85% (non-condensing)
ENCLOSURE	Totally enclosed. Self-cooled	POLES	10
PROTECTION CLASS	IP 54 Standard IP 65 with shaft sealing	CERTIFICATION	UL 1004, CSA, CE and RoHS approved Reach compliance

TC-E 180 6E G1 4 TC-E 180 6F G5 4 TC-E 180 6F M1 4 TC-E 180 6G G4 4 TC-E 180 6G L2 4

Continuous stall torque	M_0	Nm	28,65	35	35	47,75	47,75
Peak torque	M_{max}	Nm	71,62	87,53	87,53	140	140
Nominal working speed	nN	min ⁻¹	1500	1500	1500	1500	1500
Maximum working speed	nmax	min ⁻¹	4000	4000	3100	4000	3500
Nominal torque	M_n	Nm	28,65	35	35	47,75	47,75
Nominal current	I_N	A_{rms}	22,8	28,8	18,8	41,5	28,40
Nominal power	P_N	kW	4,50	5,5	5,5	7,5 ^(*)	7,5 ^(*)
Rated winding voltage	Un	V _{ac}	400	400	400	400	400
Maximum winding voltage	U_{max}	V _{dc}	650	650	650	650	650
Maximum voltage to ground		V _{ac}	265	265	265	265	265
Maximum current	Imax	A_{rms}	61,0	74,2	48,3	129	88,4
Continuous stall current	I_0	A_{rms}	19,68	25,05	16,3	36,08	27,48
Voltage Constant	K_{eu-v}	V _{rms} /K _{rpm}	88	84,5	130	80	110
Torque Constant	k_t	Nm/ A_{rms}	1,46	1,4	2,15	1,32	1,82
Winding resistance	R_{20u-v}	Ohm	0,199	0,104	0,25	0,062	0,115
Winding inductance	L_{qu-v}	mH	4,00	2,25	5,3	1,3	2,8
Winding inductance	L_{du-v}	mH	3,80	2,07	4,9	1,22	2,63
Rotor inertia without holding brake	J_M	Kgcm ²	73,31	130,33	103,33	142,69	142,69
Rotor inertia with holding brake	J_M	Kgcm ²	73,99	120,19	120,19	158,69	158,69
Mass without holding brake	m	Kg	23,64	32	32	41,7	41,7
Mass with holding brake	m	Kg	28	36,5	36,5	46,2	46,2
Thermal time constant	Tth	min	40	50	50	60	60
Maximum radial shaft load		N	1200	1200	1200	1200	1200
Maximum axial shaft load		N	497	497	497	497	497

Rated output with 550x550x20 mm steel heat sink flange coupling - Ambient temperature 40°C. Derating must be considered if the oil seal is applied

(*) TC-E 180 6G L2 4 with nominal power 7,5 kW is UL 1004, CE and RoHS approved and Reach compliance

(*) TC-E 180 6G L2 4 with nominal power 7,0 kW is UL 1004, CSA, CE and RoHS approved and Reach compliance

(*) TC-E 180 6G L2 4 with holding brake has nominal power 7,0 kW

TETRA COMPACT-E 180

230 Vac TORQUE AND SPEED CHARTS.1

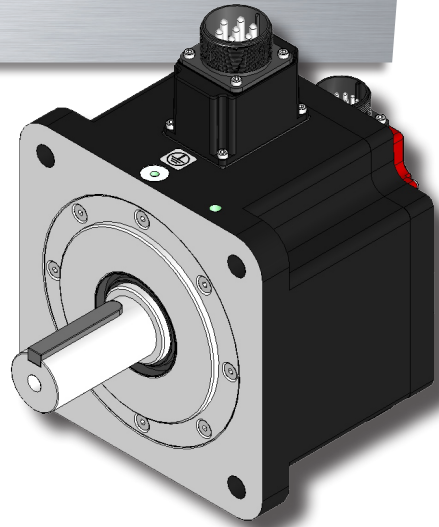

TETRA COMPACT-E 180 6A G2 2

TETRA COMPACT-E 180 6B F2 2

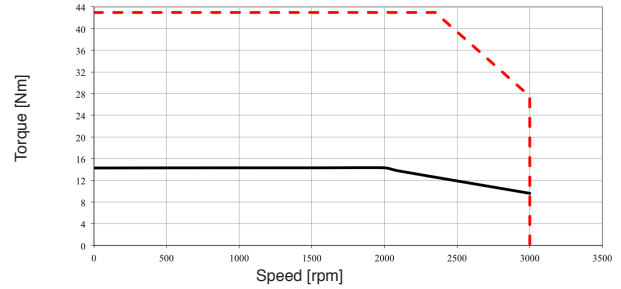
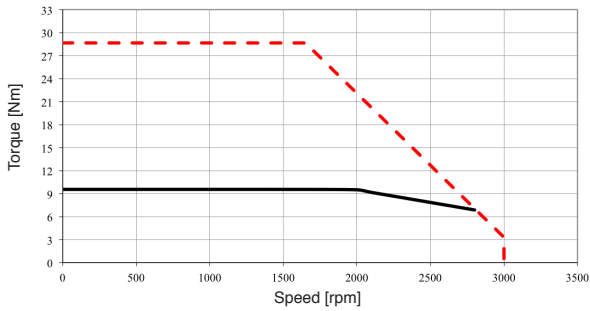

TETRA COMPACT-E 180 6C H1 2

TETRA COMPACT-E 180 6D E2 2

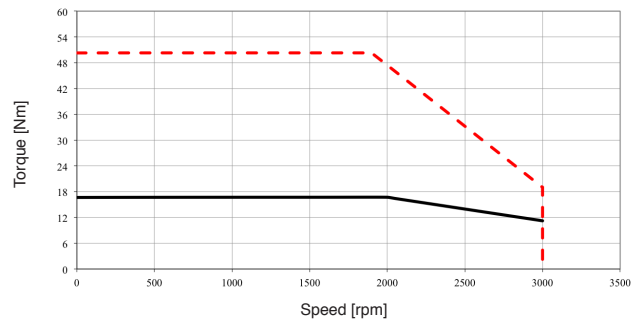
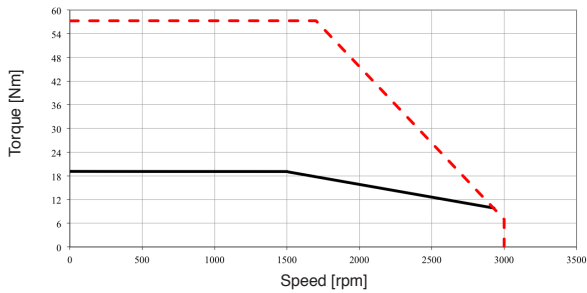

Continuous torque
 Peak torque

SEE IT BEFORE IT HAPPENS



TETRA COMPACT-E 180

230 Vac TORQUE AND SPEED CHARTS.2

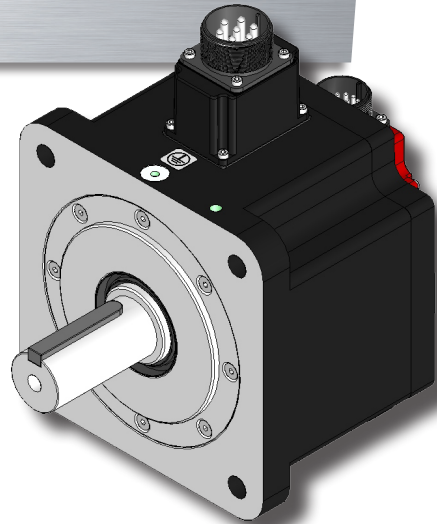

TETRA COMPACT-E 180 6E G1 2

TETRA COMPACT-E 180 6F G5 2

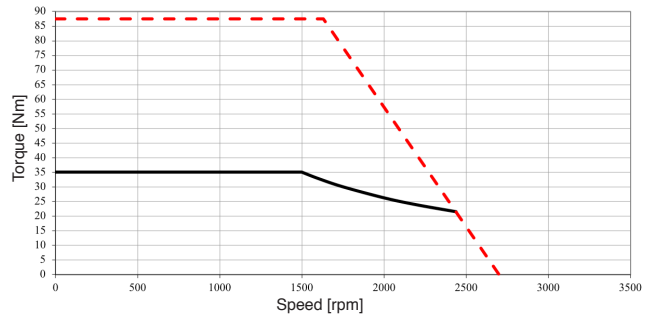
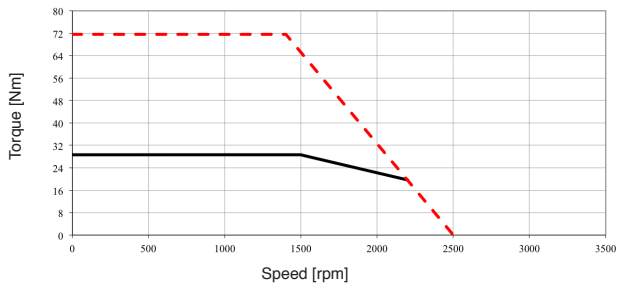

TETRA COMPACT-E 180 6G G4 2 7kW (*)

TETRA COMPACT-E 180 6G G4 2 7.5 kW (*)

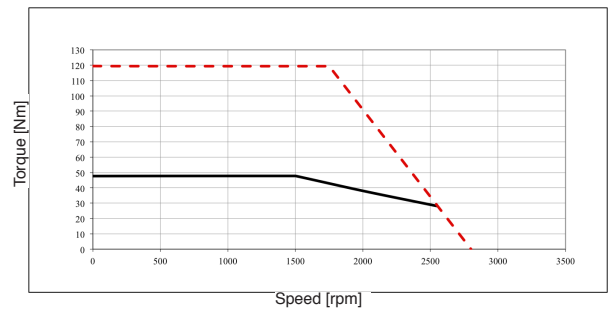
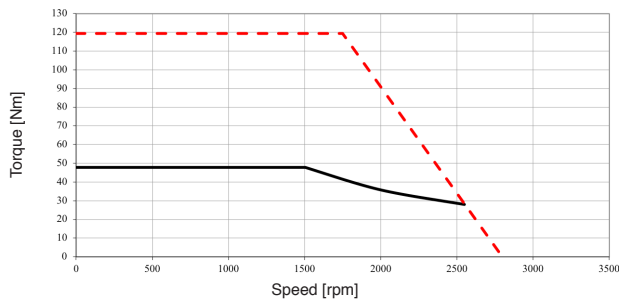

(*) TC-E 180 6G H1 2 with nominal power 7,5 kW is UL 1004, CE and Rohs approved and Reach compliance
 (*) TC-E 180 6G H1 2 with nominal power 7,0 kW is UL 1004, CSA, CE and Rohs approved and Reach compliance

TETRA COMPACT-E 180 6G G4 2 with brake

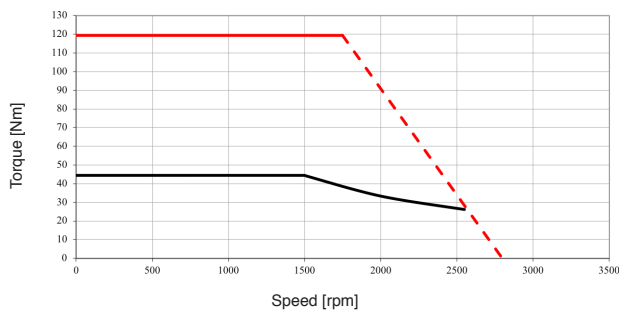

— Continuous torque
 - - - Peak torque

TETRA COMPACT-E 180

400Vac TORQUE AND SPEED CHARTS.1

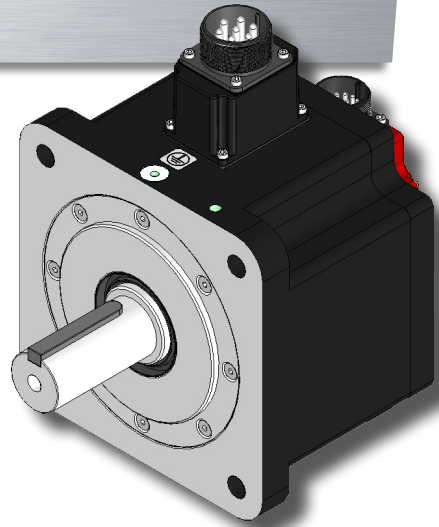

TETRA COMPACT-E 180 6A G3 4

— Continuous torque
 - - - Peak torque

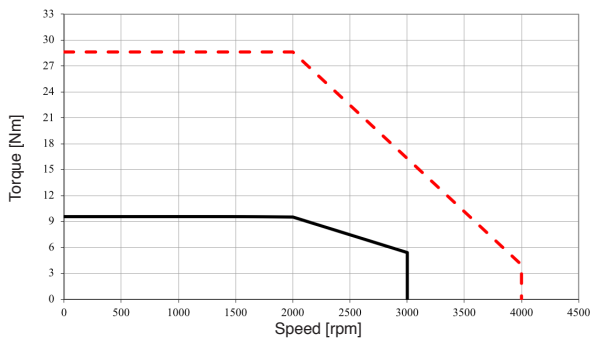

TETRA COMPACT-E 180 6B F2 4

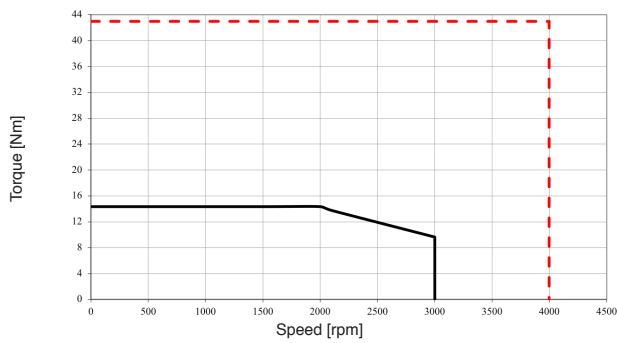

TETRA COMPACT-E 180 6C H1 4

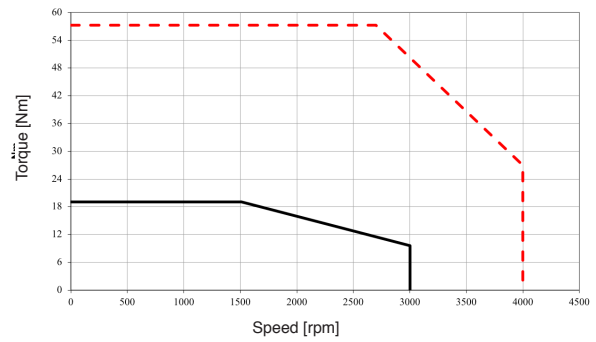

TETRA COMPACT-E 180 6D E2 4

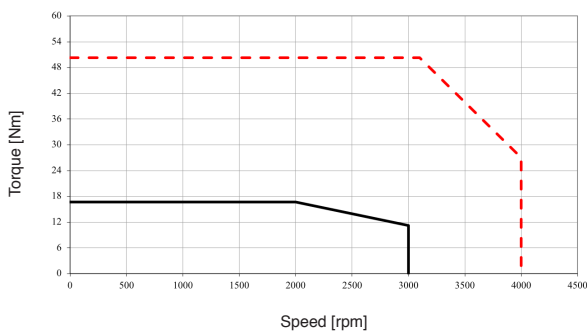

TETRA COMPACT-E 180 6E G1 4

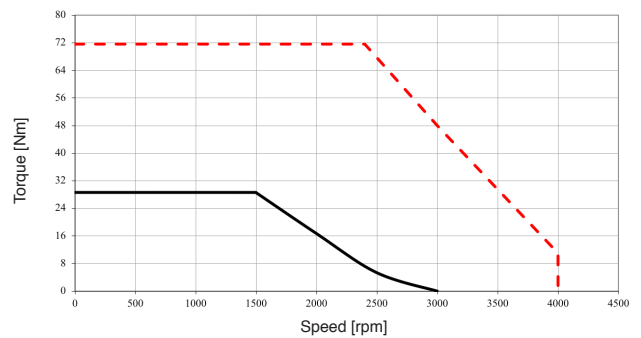

TETRA COMPACT-E 180

400 Vac TORQUE AND SPEED CHARTS.2

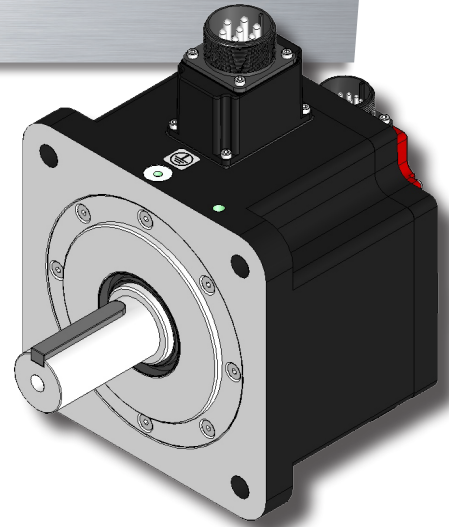

TETRA COMPACT-E 180 6F G5 4

TETRA COMPACT-E 180 6F M1 4

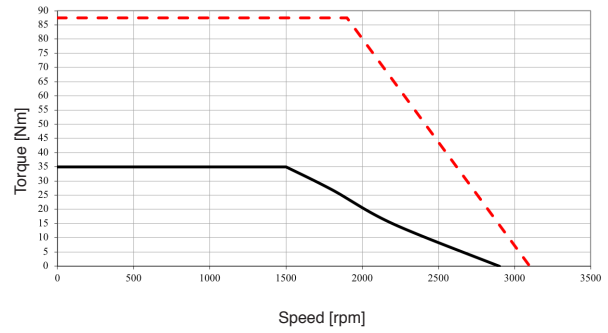
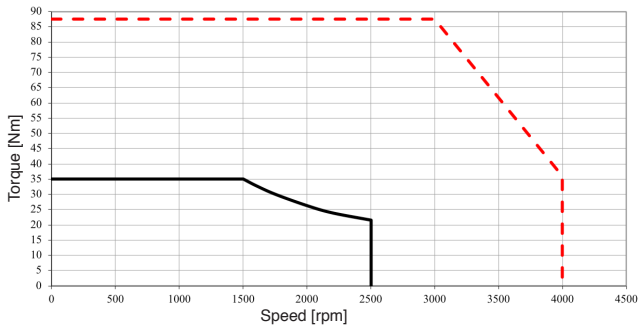

TETRA COMPACT-E 180 6G G4 4

TETRA COMPACT-E 180 6G L2 4

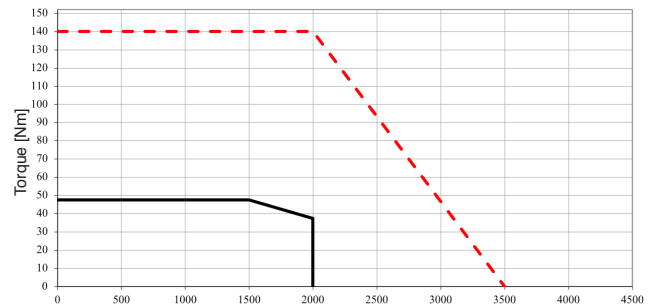
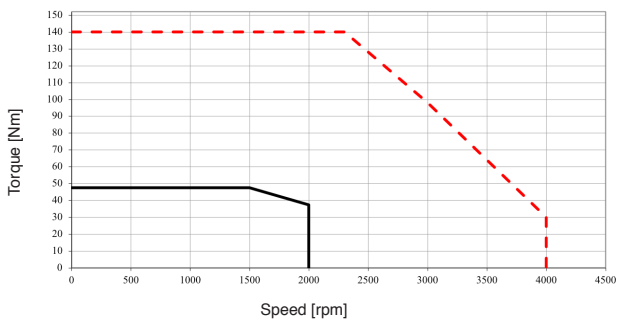

Continuous torque
 Peak torque

SEE IT BEFORE IT HAPPENS



FEEDBACK FEATURES

E1 TTL ENCODER

Motor size		TC-E 60 - 80	TC-E 100 - 130 - 180
Nominal Voltage	V	5±5%	5±5%
Nominal current	mA	200	200
Max Frequency	Khz	200	200
Electronic type		LINE DRIVER AM 26 LS31	LINE DRIVER AM 26 LS31
Zero impulse		ONE AT A LAP	ONE AT A LAP
N° of pulses revolution	ppr	2500	2500
Resolution	cpr	10000	10000
N° of commutation signal		3 DIFFERENTIAL	3 DIFFERENTIAL
System accuracy	arc sec	± 50	± 50
Rotor inertia	Kg cm ²	0.01	0.065
Maximum acceleration	rad/s ²	80.000	80.000

A1 ABSOLUTE MULTITURN ENCODER

Motor size		TC-E 40	TC-E 60-80-100-115-142-180
Nominal Voltage	V	7 ÷ 12	7 ÷ 12
Nominal current	mA	< 50	60
Max frequency for Sin Cos signal	Khz	65	65
Interface type		Hiperface	Hiperface
N° absolute singleturn steps		512 (9 Bits)	4096 (12 Bits)
N° absolute multiturn steps		4096 (12 Bits)	4096 (12 Bits)
N° of sin/cos periods per revolution		16	128
Integral non-linearity	arc sec	± 288	± 80
Rotor inertia	g cm ²	1	4.5
Maximum acceleration	rad/s ²	500.000	500.000

A2 PROPRIETARY ABSOLUTE ENCODER

The drive can access the electronic nameplate via the electronic interface for easy commissioning.
The signals meet the PELV requirements

Motor size		TC-E 40 - 60 - 80 - 100 - 130 - 180
Resolution		20 bits
Accuracy		± 0.02° / 1.2' / 72"
Maximum rotational speed	rpm	10.000
Maximum angular acceleration	rad/s ²	100.000
Operating temperature range	°C	-20 to +115
Moment of inertia	kg m ²	2.8 x 10 ⁻⁶
Nominal voltage	V	4 - 5.25
Current consumption	mA	80
Standby period at power-on	ms	1500
Communication protocol		Motor Power Company protocol

SEE IT BEFORE IT HAPPENS

**MOTOR
POWER**
COMPANY

BRAKE FEATURES

		TC-E 40	TC-E 60	TC-E 80	TC-E 100	TC-E 130	TC-E 180
Operating motor temperature	°C	-20 ...+120	-20 ...+120	-20 ...+120	-20 ...+120	-20 ...+120	-20 ...+120
External ambient temperature	°C	-20 ...+40	-20 ...+40	-20 ...+40	-20 ...+40	-20 ...+40	-20 ...+40
Standard brake duty		Stationary	Stationary	Stationary	Stationary	Stationary	Stationary
Minimum dry static torque (@-20...120°C) (*)	Nm	0,32	1,3	2,5	6,5	9,6	48
Nominal operation voltage	Vdc	24±10%	24±10%	24±10%	24±10%	24±10%	24±10%
Power consumption (@20°)	W	4,35±7%	11,2±7%	10,2±7%	10,4±7%	19,7±7%	49,6±7%
Release time	ms	22	58	46	49	71	120
Brake release time (pull in)	ms	77	25	58	30	39	37
Backlash (max)	degree	1,2	1,2	1,2	1,2	1,2	1,2

(*) Brakes are tested according to motors continuous stall torque

WIRING MOTOR CONNECTIONS

POWER CONNECTION

Function

DO

DO + Brake

C2

C3

U
V
W
PE
BRAKE_24V
BRAKE_0V

PIN
1
2
3
4
-
-

PIN
1
2
4
5
3
6

PIN
1
4
3
2
A
B

PIN
E
G
B
D
F
A

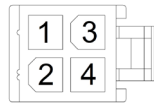

[DO]

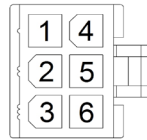

[DO + Brake]

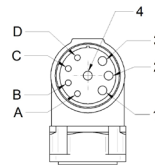

[C2]

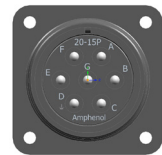

[C3 for mod. TC-E 100 and 130]

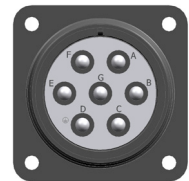

[C3 for mod. TC-E 180]

WIRING MOTOR CONNECTIONS

E1 FEEDBACK CONNECTION

D0 connection

C2 connection

C3 connection

Function

PIN

A	1
A/	2
B	3
B/	4
Z	5
Z/	6
HALL U	7
HALL U/	8
HALL V	9
HALL V/	10
HALL W	11
HALL W/	12
+5V	13
0V	14
SHIELD	15

Function

PIN

HALL W	1
HALL U	2
0V	3
+5 Vdc	4
Ch /A	5
Ch A	6
Ch /z	7
Ch z	8
HALL V	9
SHIELD	10
Ch /B	11
Ch B	12
HALL /W	13
HALL /V	14
HALL /U	15

Function

PIN

A	A
A/	B
B	C
B/	D
Z	E
Z/	F
HALL U	G
HALL U/	H
HALL V	J
HALL /V	K
HALL W	L
HALL /W	M
+5 Vdc	N
GND	P
SHIELD	R

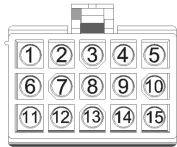

[D0]

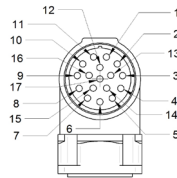

[C2]

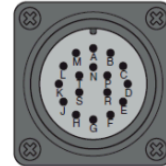

[C3]

WIRING MOTOR CONNECTIONS

A1 FEEDBACK CONNECTION

D0 connection

C2 connection

C3 connection

Function

PIN

DATA +	1
+ SIN	2
REFSIN	3
DATA -	4
+ COS	5
REFCOS	6
8V/ Us	7
GND	8
SHIELD	9

Function

PIN

GND	3
Us (+7Vdc ÷ +12Vdc)	4
REFSIN	5
+ SIN	6
DATA -	7
DATA +	8
SHIELD	10
REFCOS	11
+ COS	12

Function

PIN

8V/ Us	A
+ SIN	B
REFSIN	C
+ COS	D
REFCOS	E
GND	F
DATA -	G
DATA -	H
SHIELD	J

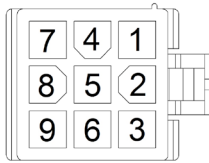

[D0]

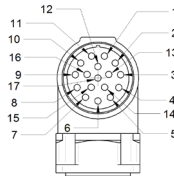

[C2]

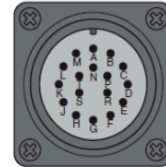

[C3]

A2 FEEDBACK CONNECTION

Function

D0 connection

C2 connection

C3 connection

DATA +
DATA -
-
-
-
-
DC +5V (BATTERY +)
GND (BATTERY -)
SHIELD

PIN

1
4
2
3
5
6
7
8
9

PIN

6
5
-
-
-
-
4
3
10

PIN

A
B
C
D
F
G
S
R
L

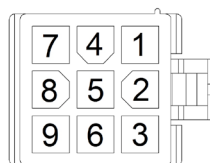

[D0]

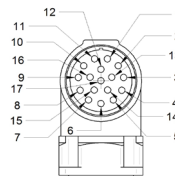

[C2]

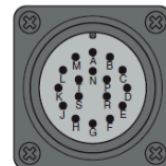

[C3]

SEE IT BEFORE IT HAPPENS

CABLES SPECIFICATIONS

Dynamic laying cable E83517 – cAUs AWM STYLE 21223 certified

POWER CABLES for models TC-E 40-60-80 without holding brake for DO connection

PIN motor side	FUNCTION	Cable wire colour	For cable order	
1	FASE U	Black 1	Length (mm)	Order code
4	FASE V	Black 2		
7	FASE W	Black 3		
8	PE	Yellow-Green		
			3000	003108015156
			5000	003108015157
			10000	003108015155

Power free wire cable for FLEXI-PRO and general purpose

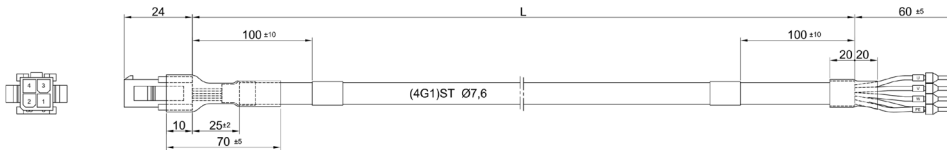

POWER CABLES for models TC-E 40-60-80 with holding brake for DO connection

PIN motor side	FUNCTION	Cable wire colour	For cable order	
1	FASE U	Black 1	Length (mm)	Order code
2	FASE V	Black 2		
4	FASE W	Black 3		
5	PE	Yellow-Green		
3	BRAKE 1	Brown		
6	BRAKE 2	White		
			3000	003108015159
			5000	003108015160
			10000	003108015158

Power free wire cable for FLEXI-PRO and general purpose

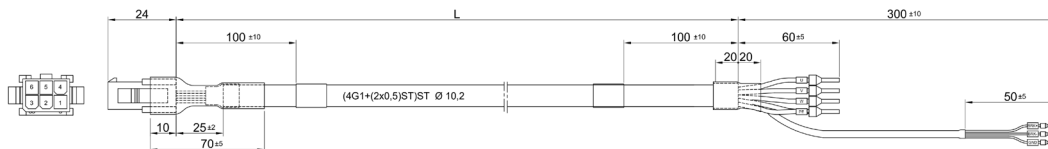

POWER CABLES for models TC-E 100 4A - 130 5A - 130 5B - 130 5C - 130 5D - 130 5E - 130 5F - 130 5G without holding brake for C3 connection

PIN motor side	FUNCTION	Cable wire colour	For cable order	
E	FASE U	White	Length (mm)	Order code
G	FASE V	Black		
B	FASE W	Red		
D	PE	Yellow-Green		
			3000	003108015244
			5000	003108015245
			10000	003108015246

Power free wire cable for FLEXI-PRO and general purpose

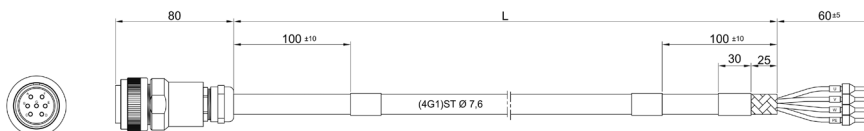

CABLES SPECIFICATIONS

Dynamic laying cable E83517 – cRUus AWM STYLE 21223 certified

POWER CABLES for models TC-E 100 4A - 130 5A - 130 5B - 130 5C - 130 5D - 130 5E - 130 5F - 130 5G with holding brake for C3 connection

PIN motor side	FUNCTION	Cable wire colour	For cable order	
E	FASE U	White	Lenght (mm)	Order code
G	FASE V	Black		
B	FASE W	Red	3000	003108015247
D	PE	Yellow-Green	5000	003108015248
F	BK +	Red	10000	003108015249
A	BK -	Black		

Power free wire cable for FLEXI-PRO and general purpose

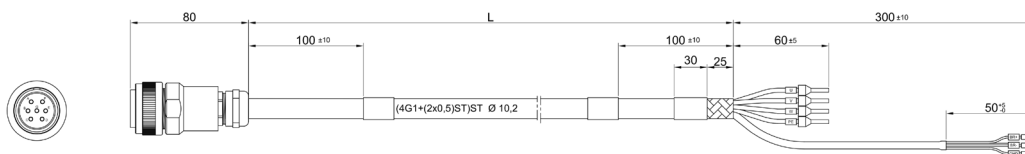

POWER CABLES for models TC-E 100 4B - 130 5H without holding brake for C3 connection

PIN motor side	FUNCTION	Cable wire colour	For cable order	
E	FASE U	White	Lenght (mm)	Order code
G	FASE V	Black		
B	FASE W	Red	1500	003108015164
D	PE	Yellow-Green	3000	003108015165
			5000	003108015166
			10000	003108015228

Power free wire cable for FLEXI-PRO and general purpose

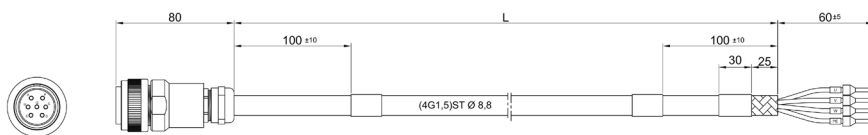

POWER CABLES for models TC-E 100 4B - 130 5H with holding brake for C3 connection

PIN motor side	FUNCTION	Cable wire colour	For cable order	
E	FASE U	White	Lenght (mm)	Order code
G	FASE V	Black		
B	FASE W	Red	3000	003108015168
D	PE	Yellow-Green	5000	003108015169
F	BK +	Red	10000	003108015167
A	BK -	Black		

Power free wire cable for FLEXI-PRO and general purpose

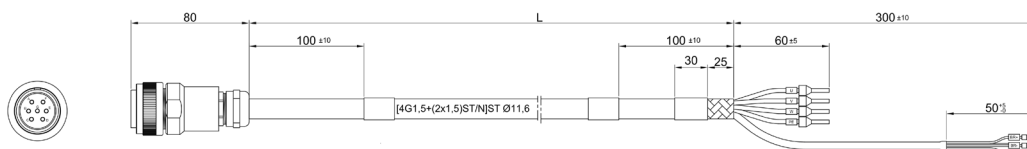

CABLES SPECIFICATIONS

Dynamic laying cable E83517 – cRUus AWM STYLE 21223 certified

POWER CABLES for models TC-E 180 6A - 180 6B - 180 6C - 180 6D without holding brake for C3 connection

PIN motor side	FUNCTION	Cable wire colour	For cable order	
1	FASE U	Black 1	Lenght (mm)	Order code
4	FASE V	Black 2		
7	FASE W	Black 3		
8	PE	Yellow-Green		
			3000	003108015177
			5000	003108015178
			10000	003108015176

Power free wire cable for FLEXI-PRO and general purpose

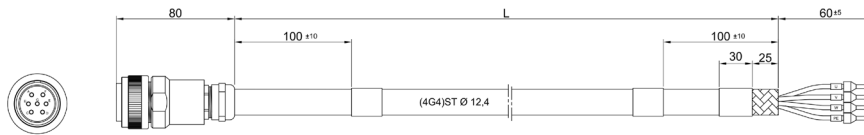

POWER CABLES for models TC-E 180 6A - 180 6B - 180 6C - 180 6D with holding brake for C3 connection

PIN motor side	FUNCTION	Cable wire colour	For cable order	
E	FASE U	White	Lenght (mm)	Order code
G	FASE V	Black		
B	FASE W	Red		
D	PE	Yellow-Green		
F	BK +	Red		
A	BK -	Black		
			3000	003108015180
			5000	003108015181
			10000	003108015179

Power free wire cable for FLEXI-PRO and general purpose

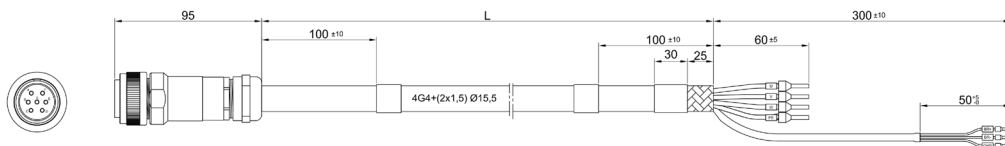

SEE IT BEFORE IT HAPPENS

CABLES SPECIFICATIONS

Dynamic laying cable E83517 – cRUus AWM STYLE 21223 certified

POWER CABLES for models TC-E 180 6E - 180 6F - 180 6G without holding brake for C3 connection

PIN motor side	FUNCTION	Cable wire colour	For cable order	
1	FASE U	Black 1	Lenght (mm)	Order code
4	FASE V	Black 2		
7	FASE W	Black 3		
8	PE	Yellow-Green		
			3000	003108015183
			5000	003108015184
			10000	003108015182

Power free wire cable for FLEXI-PRO and general purpose

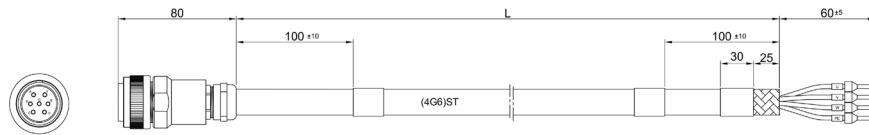

POWER CABLES for models TC-E 180 6E - 180 6F - 180 6G with holding brake for C3 connection

PIN motor side	FUNCTION	Cable wire colour	For cable order	
E	FASE U	White	Lenght (mm)	Order code
G	FASE V	Black		
B	FASE W	Red		
D	PE	Yellow-Green		
F	BK +	Red		
A	BK -	Black		
			3000	003108015186
			5000	003108015187
			10000	003108015185

Power free wire cable for FLEXI-PRO and general purpose

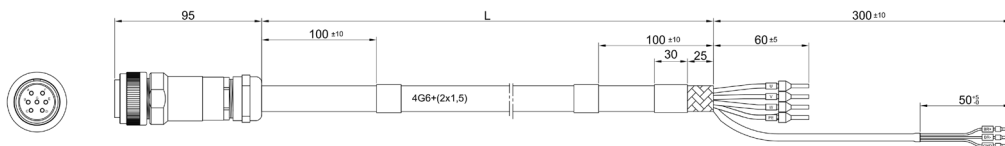

SEE IT BEFORE IT HAPPENS

**MOTOR
POWER**
COMPANY

CABLES SPECIFICATIONS

Dynamic laying cable E83517 – cАUs AWM STYLE 21223 certified

POWER CABLES for models TC-E 60- 80 -100 4A - 130 5A - 130 5B - 130 5C - 130 5D - 130 5E - 130 5F - 130 5G without holding brake for C2 connection

PIN motor side	FUNCTION	Cable wire colour	For cable order	
1	FASE U	Black	Lenght (mm)	Order code
4	FASE V	Black		
3	FASE W	Black	3000	003108015250
2	PE	Yellow-Green	5000	003108015251
			10000	003108015252

Power free wire cable for FLEXI-PRO and general purpose

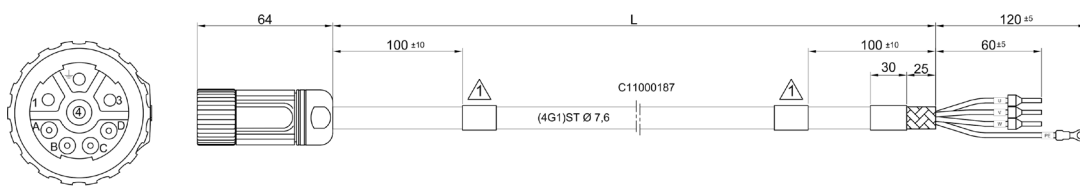

POWER CABLES for models TC-E 60 - 80 - 100 4A - 130 5A - 130 5B - 130 5C - 130 5D - 130 5E - 130 5F - 130 5G with holding brake for C2 connection

PIN motor side	FUNCTION	Cable wire colour	For cable order	
1	FASE U	Black	Lenght (mm)	Order code
4	FASE V	Black		
3	FASE W	Black	3000	003108015253
2	PE	Yellow-Green	5000	003108015254
A	BK +	Black	10000	003108015255
B	BK -	White		

Power free wire cable for FLEXI-PRO and general purpose

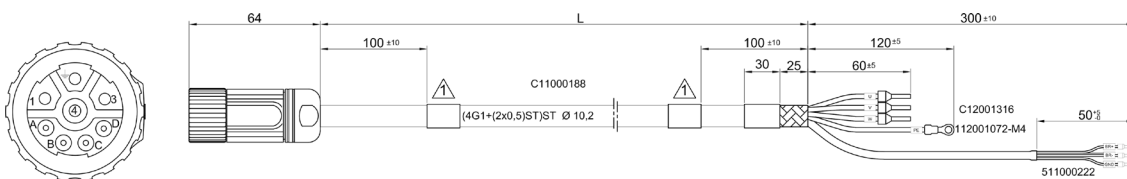

POWER CABLES for models TC-E 100 4B - 130 5H without holding brake for C2 connection

PIN motor side	FUNCTION	Cable wire colour	For cable order	
1	FASE U	Black	Lenght (mm)	Order code
4	FASE V	Black		
3	FASE W	Red	3000	003108015192
2	PE	Black	5000	003108015193
			10000	003108015191

Power free wire cable for FLEXI-PRO and general purpose

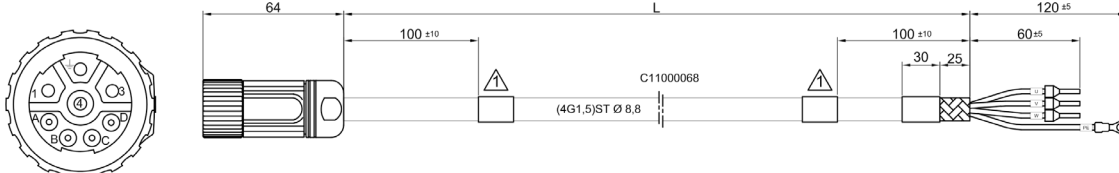

CABLES SPECIFICATIONS

Dynamic laying cable E83517 – cPAUs AWM STYLE 21223 certified

POWER CABLES for models TC-E 100 4B - 130 5H with holding brake for C2connection

PIN motor side	FUNCTION	Cable wire colour	For cable order	
1	FASE U	Black	Length (mm)	Order code
4	FASE V	Black	3000	003108015195
3	FASE W	Black	5000	003108015196
2	PE	Yellow-Green	10000	003108015194
A	BK +	Black		
B	BK -	White		

Power free wire cable for FLEXI-PRO and general purpose

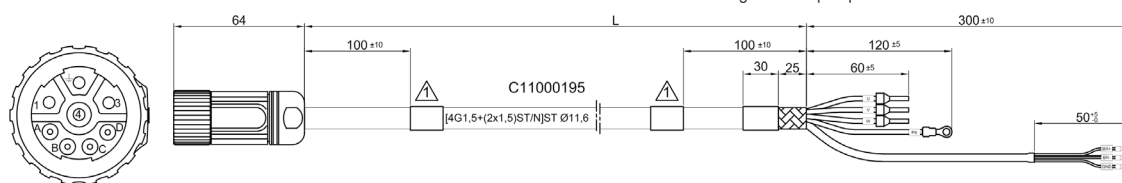

POWER CABLES for models TC-E 180 6A - 180 6B - 180 6C - 180 6D without holding brake for C2 connection

PIN motor side	FUNCTION	Cable wire colour	For cable order	
1	FASE U	Black	Length (mm)	Order code
4	FASE V	Black	3000	003108015204
3	FASE W	Black	5000	003108015205
2	PE	Yellow-Green	10000	003108015203

Power free wire cable for FLEXI-PRO and general purpose

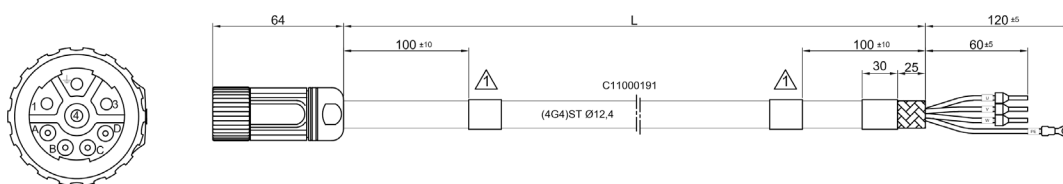

POWER CABLES for models TC-E 180 6A - 180 6B - 180 6C - 180 6D with holding brake for C2 connection

PIN motor side	FUNCTION	Cable wire colour	For cable order	
1	FASE U	Black	Length (mm)	Order code
4	FASE V	Black	3000	003108015207
3	FASE W	Black	5000	003108015208
2	PE	Yellow-Green	10000	003108015206
A	BK +	Black		
B	BK -	White		

Power free wire cable for FLEXI-PRO and general purpose

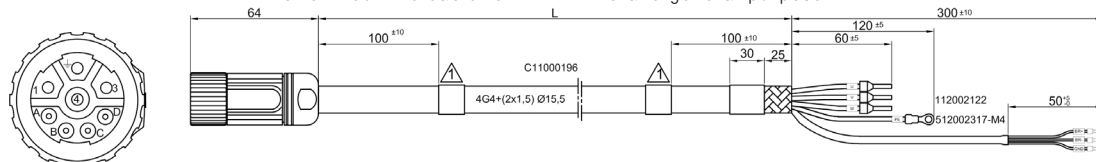

CABLES SPECIFICATIONS

Dynamic laying cable E83517 cULus AWM STYLE 20233 and E83517 – cRUus AWM STYLE 20549 certified

SIGNAL CABLES for models TC-E 40-60-80 feedback A1 absolute multiturn encoder for DO connection

PIN motor side	FUNCTION	PIN drive side	For cable order	
1	DATA +	1	Length (mm)	Order code
2	SIN +	9		
3	SIN -	22		
4	DATA -	14		
5	COS +	10		
6	COS -	23		
7	8 VDC	18		
8	GND	24		
9	SHIELD	26		

Signal wired cable for FLEXI-PRO with absolute multiturn encoder

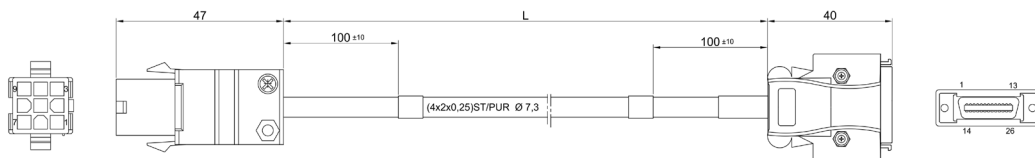

SIGNAL CABLES for models TC-E 40-60-80 feedback E1 incremental encoder for DO connection

PIN motor side	FUNCTION	PIN drive side	For cable order	
1	A	1	Length (mm)	Order code
2	A/	14		
3	B	2		
4	B/	15		
5	Z	3		
6	Z/	16		
7	HU	4		
8	HU/	NC		
9	HV	17		
10	HV/	NC		
11	HW	5		
12	HW/	NC		
13	5 VDC	11		
14	GND	24		
15	SHIELD	26		

Signal wired cable for FLEXI-PRO with incremental encoder

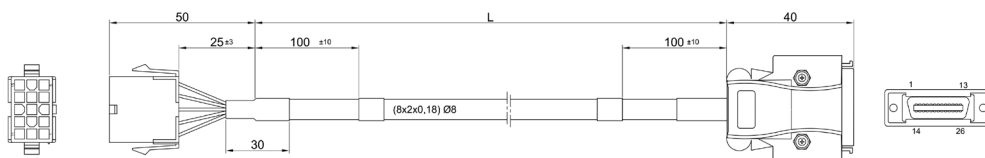

CABLES SPECIFICATIONS

Dynamic laying cable E83517 cULus AWM STYLE 20233 and E83517 – cRUus AWM STYLE 20549 certified

SIGNAL CABLES for models TC-E 40-60-80 feedback A2 20 bit absolute encoder for D0 connection

PIN motor side	FUNCTION	PIN drive side	For cable order	
1	DATA +	1	Lenght (mm)	Order code
4	DATA -	14	3000	003108015162
7	5 VDC	11	5000	003108015163
8	GND	24	10000	003108015161
9	SHIELD	26		

Signal wired cable for FLEXI-PRO with 20 bit absolute encoder

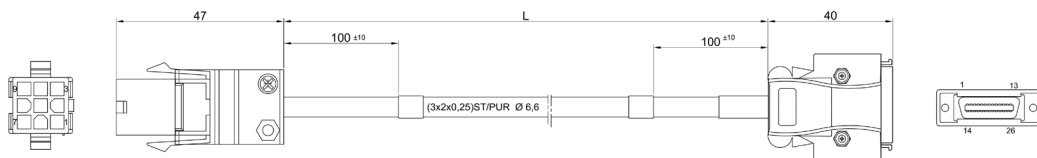

SIGNAL CABLES for models TC-E 100 - 130 - 180 feedback A1 absolute multiturn encoder for C3 connection

PIN motor side	FUNCTION	PIN drive side	For cable order	
A	8 VDC	18	Lenght (mm)	Order code
B	SIN +	9	3000	003108015213
C	SIN -	22	5000	003108015214
D	COS +	10	10000	003108015212
E	COS -	23		
F	GND	24		
G	DATA +	1		
H	DATA -	14		
J	SHIELD	26		

Signal wired cable for FLEXI-PRO with absolute multiturn encoder

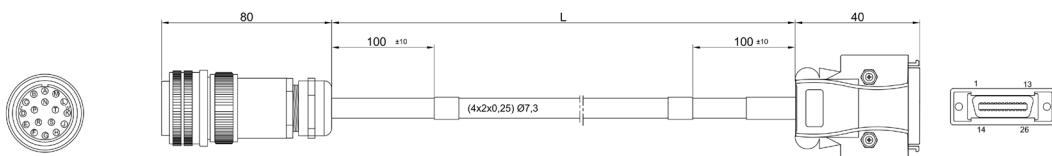

SEE IT BEFORE IT HAPPENS

CABLES SPECIFICATIONS

Dynamic laying cable E83517 cULus AWM STYLE 20233 and E83517 – сЯUus AWM STYLE 20549 certified

SIGNAL CABLES for models TC-E 100 - 130 - 180 feedback E1 incremental encoder for C3 connection

PIN motor side	FUNCTION	PIN drive side	For cable order	
A	A	1	Lenght (mm)	Order code
B	A/	14		
C	B	2	3000	003108015222
D	B/	15	5000	003108015223
E	Z	3	10000	003108015221
F	Z/	16		
G	HU	4		
H	HU/	NC		
J	HV	17		
K	HV/	NC		
L	HW	5		
M	HW/	NC		
N	5 VDC	11		
P	GND	24		
Q	SHIELD	26		

Signal wired cable for FLEXI-PRO with incremental encoder

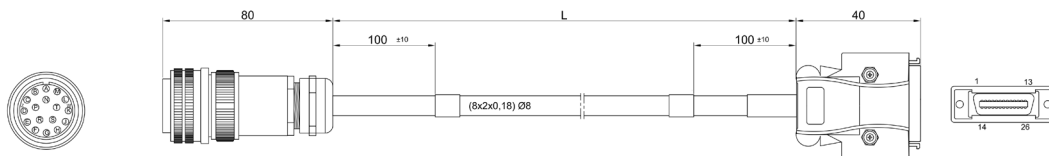

SIGNAL CABLES for models TC-E 100 - 130 - 180 feedback A2 20 bit absolute encoder for C3 connection

PIN motor side	FUNCTION	PIN drive side	For cable order	
A	DATA +	1	Lenght (mm)	Order code
B	DATA -	14		
S	5 VDC	11	1500	003108015188
R	GND	24	3000	003108015189
L	SHIELD	26	5000	003108015190
			10000	003108015227

Signal wired cable for FLEXI-PRO with 20 bit absolute encoder

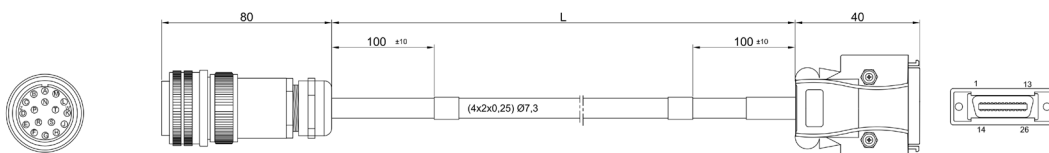

CABLES SPECIFICATIONS

Dynamic laying cable E83517 cULus AWM STYLE 20233 and E83517 – cRUus AWM STYLE 20549 certified

SIGNAL CABLES for models TC-E 60 - 80 - 100 - 130 - 180 feedback A1 absolute multiturn encoder for C2 connection

PIN motor side	FUNCTION	PIN drive side	For cable order	
4	8 VDC	18	Lenght (mm)	Order code
6	SIN +	9		
5	SIN -	22	3000	003108015216
12	COS +	10	5000	003108015217
11	COS -	23	10000	003108015215
3	GND	24		
8	DATA +	1		
7	DATA -	14		
10	SHIELD	26		

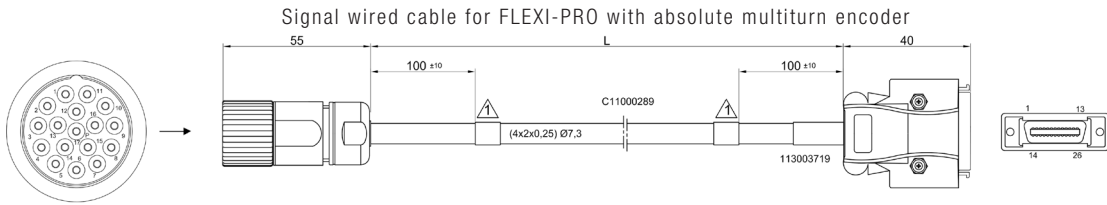

SIGNAL CABLES for models TC-E 60 - 80 - 100 - 130 - 180 feedback E1 incremental encoder for C2 connection

PIN motor side	FUNCTION	PIN drive side	For cable order	
6	A	1	Lenght (mm)	Order code
5	A/	14		
12	B	2	3000	003108015225
11	B/	15	5000	003108015226
8	Z	3	10000	003108015224
7	Z/	16		
2	HU	4		
15	HU/	NC		
9	HV	17		
14	HV/	NC		
1	HW	5		
13	HW/	NC		
4	5 VDC	11		
3	GND	24		
10	SHIELD	26		

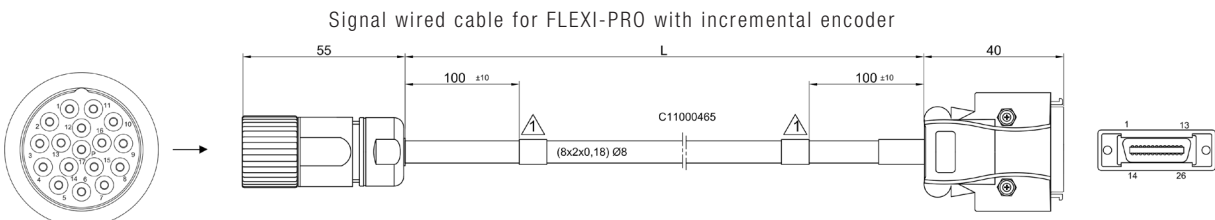

CABLES SPECIFICATIONS

Dynamic laying cable E83517 cULus AWM STYLE 20233 and E83517 – cRUus AWM STYLE 20549 certified

SIGNAL CABLES for models TC-E 60 - 80 - 100 - 130 - 180 feedback A2 20 bit absolute encoder for C2 connection

PIN motor side	FUNCTION	PIN drive side	For cable order	
6	DATA +	1	Lenght (mm)	Order code
5	DATA -	14	3000	003108015230
4	5 VDC	11	5000	003108015231
3	GND	24	10000	003108015229
10	SHIELD	26		

Signal wired cable for FLEXI-PRO with 20 bit absolute encoder

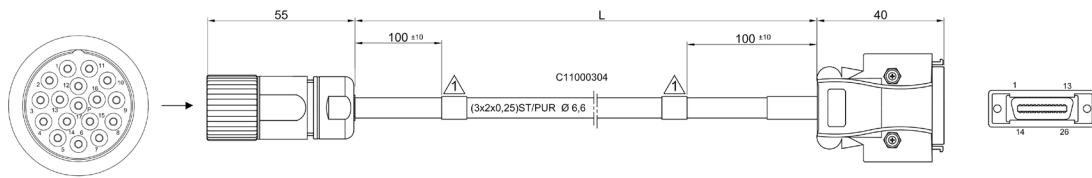

SEE IT BEFORE IT HAPPENS

CONNECTOR SPECIFICATIONS

FLYING CONNECTORS for DO connection

Power Connector
for TC-E 40-60-80 Molex 4p order code 007117000088

Power Connector
for TC-E 40-60-80 with brake Molex 6p order code 007117000086

Signal Connector
for TC-E 40-60-80 Amp 9p order code 007117000084

FLYING CONNECTORS FOR C2 connection

Power connector pin included
BSTA108NN00580236000 + 4 PIN 60.003.11 FM/2mm
CRIMP.0,35-2,5 SPRING + 4 PIN 60.001.11 FM/1mm
CRIMP.0,14-1 SPRING order code 007117000472



Signal connector pin included
ASTA014NN00410235000 17p/FM + 17 PIN 60.011.11
FM/1mm CRIMP.0,14-1 order code 007117000462



FLYING CONNECTORS for C3 connection

Signal Connector for TC-E 100, 130, 180
97-3106AMI20- 29S(417)(946)(M16)(A99) order code 005117001770

Power Connector for TC-E 100 and 130
DL31.06A.20-15S (PG16) order code 005117001766

Power Connector for TC-E 180
DLC31.06A.24-10S (PG21) order code 005117001768

FLYING CONNECTOR DIMENSIONS

FLYING CONNECTORS for C2 connection (90° M23 turnable connectors)

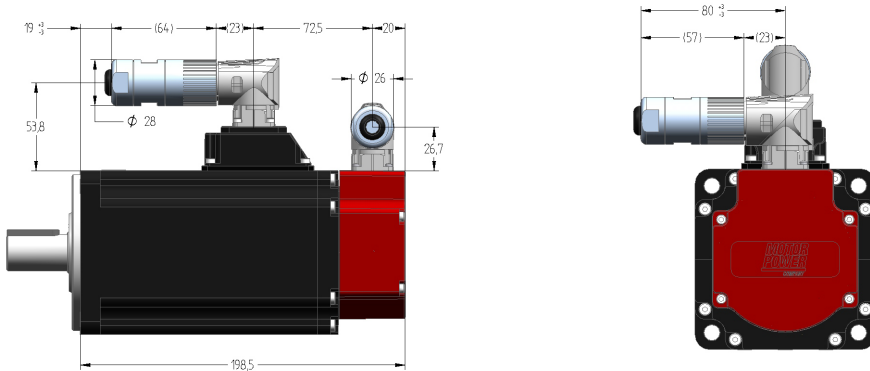

FLYING CONNECTORS for C3 connection for TC-E 100-130 (90° MS connectors)

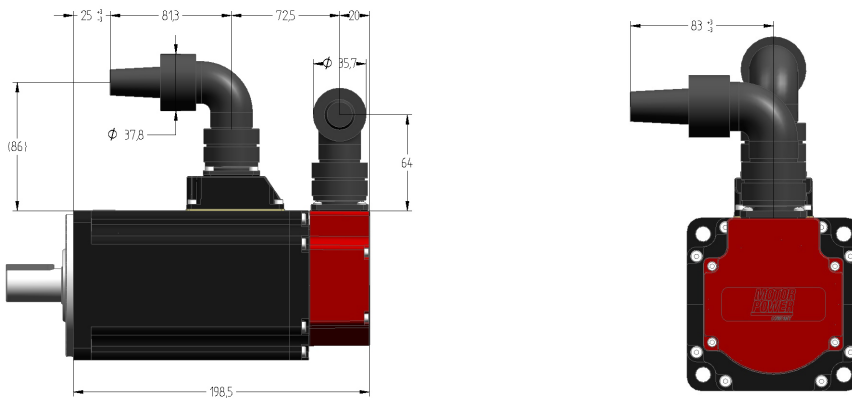

FLYING CONNECTORS for C3 connection for TC-E 180 (90° MS connectors)

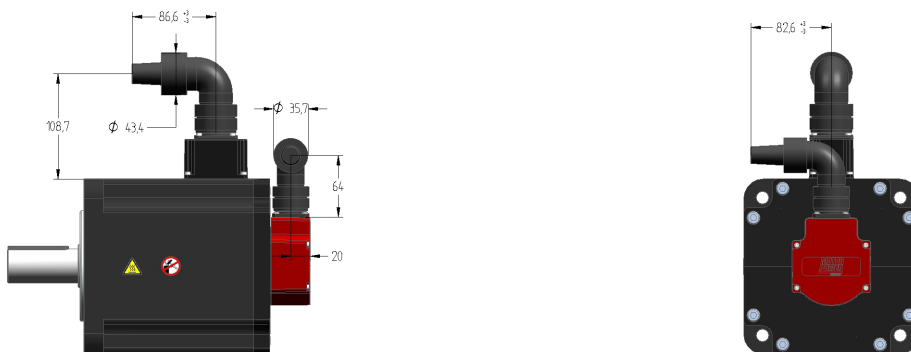

FLYING CONNECTORS for C3 connection for MS connectors

Radius curvature $RD=10 \times D$ and $Rd = 10 \times d$

TC-E 100 and 130

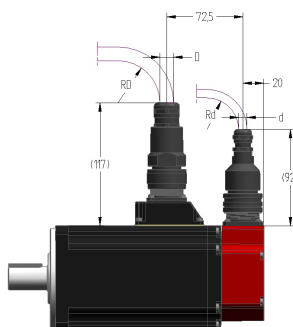

TC-E 180

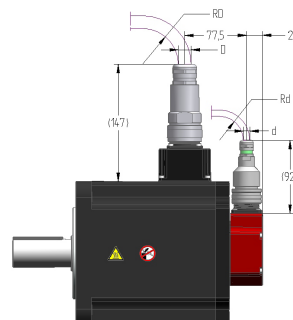

TRANSPORTATION AND STORAGE

The storage time is primarily limited by the service life of the lubricants in the bearings; do not store the product for more than 36 months. It is recommended to periodically operate the motor.

TOPIC	UNIT	VALUE
Temperature	[°C]	-40 ... 70
Relative humidity (non-condensing)	[%]	≤75
Set of class combinations as per IEC 60721-3-2		IE 21

HANDLING INSTRUCTION

Consider the mass of the product when mounting the motor. It may be necessary to use suitable lifting gear in two points.

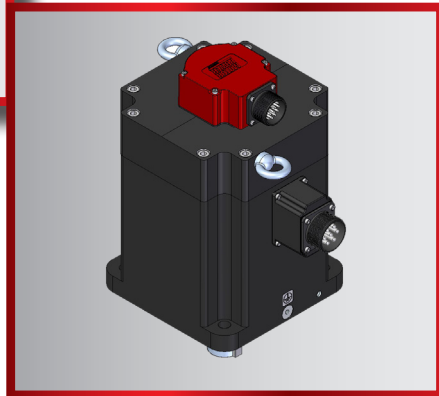
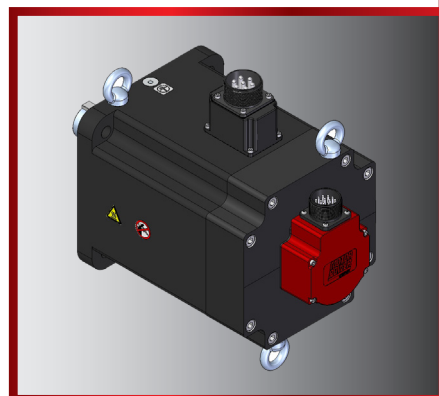
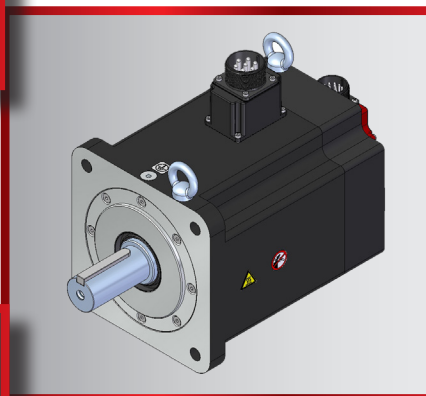
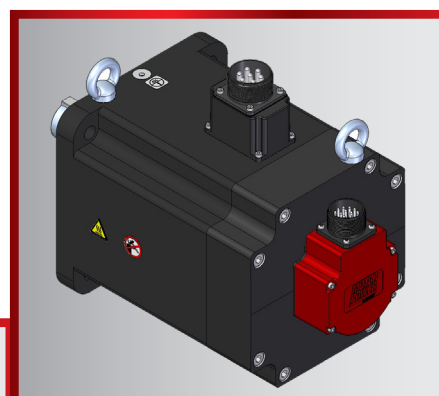
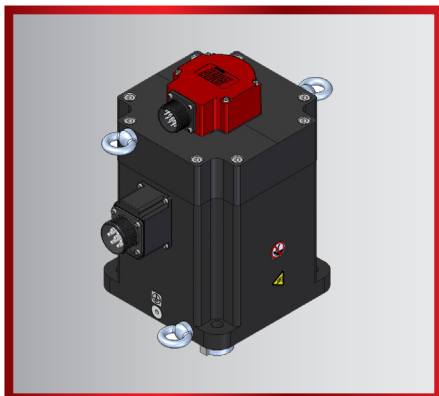

SEE IT BEFORE IT HAPPENS

**MOTOR
POWER**
COMPANY

PROTECTION CLASS

IP 54 Standard - IP 65 Option

The possible protection class at the machine depends on the position in which the motor will be mounted. According to DIN 42950 part 1 (edition 08.77), the motors can be mounted on the machine as follows:

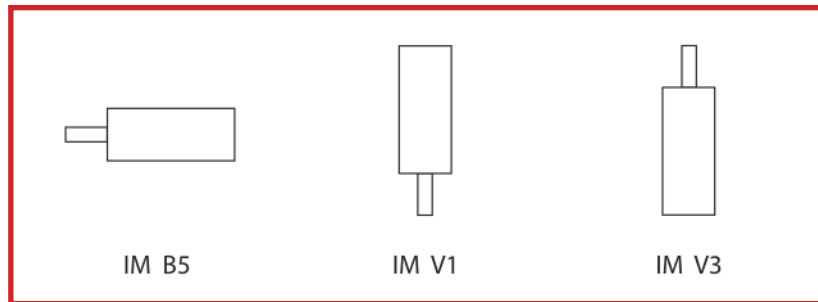

MOTOR PART	PROTECTION CLASS	MOUNTING POSITION / REMARK
Shaft	IP54	IMB5, IMV1
	IP50	IMV3
	IP65	in IMV3 shaft sealing required
Housing	Standard: IP54	Without shaft sealing
	Optional: IP65	IP65 with shaft sealing
Power / FDBK interface @ motor side	Standard: IP65	Flying leads & Military connector
Flying leads plug on cable	IP40 ¹⁾	
Cooling system	Standard convection: see housing	

¹⁾ Wires are protected by a heat shrink tubing

CLIMATIC ENVIRONMENTAL CONDITIONS OPERATION

TOPIC	UNIT	VALUE
Ambient temperature without holding brake ¹⁾ (no icing, non-condensing)	[°C]	-20 ... 40
Motor with holding brake ambient temperature ¹⁾ (no icing, non-condensing)	[°C]	-20 ... 40
Ambient temperature with current derating of 1% per °C ¹⁾	[°C]	40 ... 60
Relative humidity (non-condensing)	[%]	5 ... 85
Class as per IEC 60721-3-3		3K3, 3Z12, 3Z2, 3B2, 3C1, 3M6
Installation altitude ²⁾	[m]	≤1000
Installation altitude with current derating of 1% per 100 m at altitudes of more than 1000 m ²⁾	[m]	1000 ... 3000

¹⁾ Limit values with flanged motor.

²⁾ The installation altitude is defined as altitude above mean sea level.

OIL SEAL

Oil seal material is FPM (trade name Viton).

With shaft sealing ring the maximum speed of rotation is limited to 5000 rpm. Shaft sealing ring is provided with initial lubrication, if the sealing ring runs dry this increases friction and reduces service life. Derating must be considered if the oil seal is applied.

ADDITIONAL GROUND CONDUCTOR CONNECTION

Ground the motor via a grounding screw if grounding via the flange and the protective ground conductor of the motor cable is not sufficient. Use parts with suitable corrosion protection.



SEE IT BEFORE IT HAPPENS

**MOTOR
POWER**
COMPANY

BEARINGS

Rolling contact bearing with permanent grease lubrication; closed on both sides of the bearing.

Lifetime min L 10h = 20.000 hours

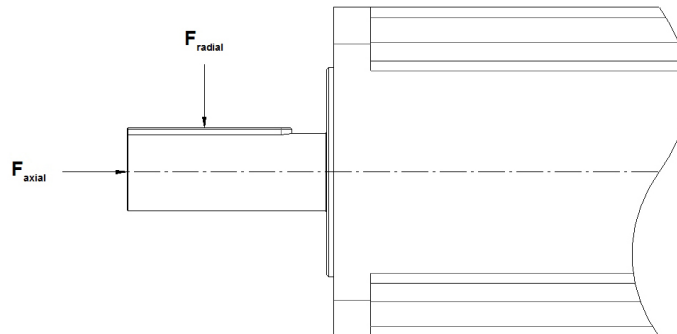

SHOCK AND VIBRATION

TOPIC

VALUE

Vibration, sinusoidal	Type test with 10 runs as per IEC 60068-2-6 0.15 mm (von 10 Hz ... 60 Hz) 20 m/s ² (from 60 Hz ... 500 Hz)
Shock, semi-sinusoidal	Type test with 3 shocks in each direction as per IEC 60068-2-27 100 m/s ² (11 ms)

FLANGE SIZES FOR RATED OUTPUT VALUES

Rated output limit values are referring to this table relate to flanged motors with the following flange sizes

Motor model	Flange material	Flange size in [mm]
TC-E 40	Aluminum	185x185x8
TC-E 60	Aluminum	250x250x12
TC-E 80	Aluminum	250x250x12
TC-E 100	Steel	300x300x20
TC-E 130	Steel	400x400x20
TC.E 180	Steel	550x550x20

SEE IT BEFORE IT HAPPENS





SEE IT BEFORE IT HAPPENS

**MOTOR
POWER**
COMPANY



Motor Power Company
www.motorpowerco.com
info@motorpowerco.it

All rights reserved.
Complete or partial reproduction
is not allowed without our permission.

All technical data in this catalog
may be changed without prior notice.

SEE IT BEFORE IT HAPPENS

**MOTOR
POWER**
COMPANY

motorpowerco.com

MOTION CONTROL

MECHATRONICS

TC-E & Flexi-Pro Catalogue 4.1/05.19

**MOTOR
POWER**
COMPANY

Motor Power Company s.r.l.

Via Leonardo Da Vinci, 4
42024 Castelnovo Sotto
Reggio Emilia - Italia
Tel. 0039 0522 682710
Fax 0039 0522 683552
info@motorpowerco.it

Motor Power Company GmbH

Dillberg, 11
97828 Marktheidenfeld
Germany
Tel 0049 9391 9198905
Fax 0049 9391 9198907
info@motorpowerco.de

Motor Power Company Asia Ltd.

Workshop 7, Shiny Science Park No.
111, Dong Ting North Rd.
215400 Taicang, Jiangsu Province
P.R.China
Tel 0086 512 33337978
Fax 0086 512 53207871
infoasia@motorpowerco.com