

# Mercury™ 2000, 3000 & 3500

Smart Programmable Encoder Systems

*Installation Manual  
and Reference Guide*

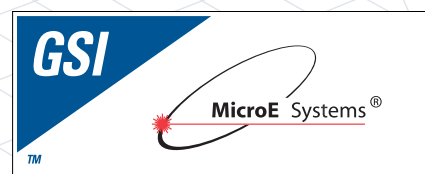

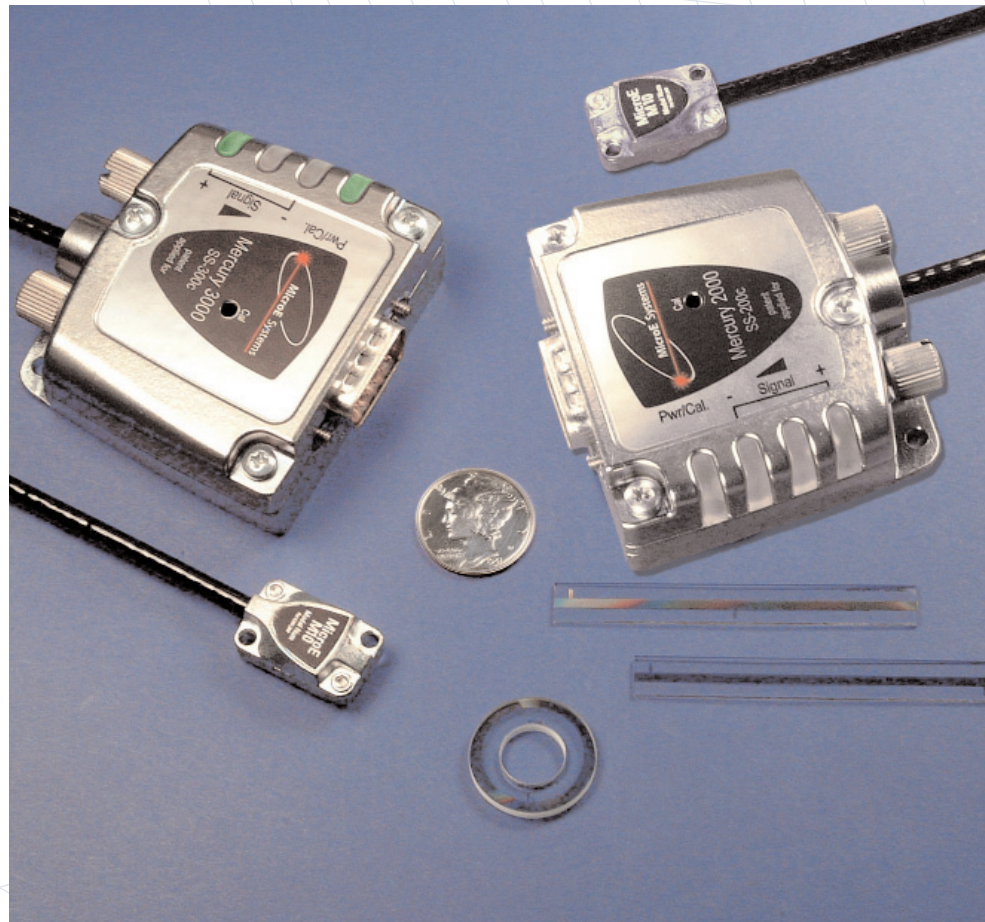
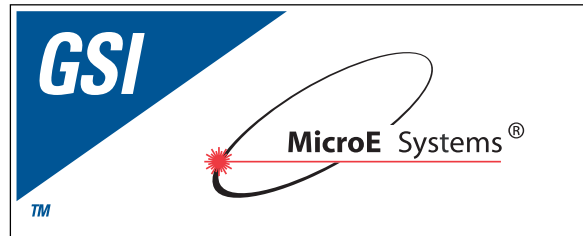

**M**icroE Systems was founded to advance encoder technology to a level never before achieved. Our objective was to design encoder systems that would be small enough to fit into densely packed OEM equipment designs, affordable enough for cost-sensitive applications and easy enough to enable installation, setup and alignment by assemblers with little training. We are pleased to say that all of these goals have been realized with the introduction of the Mercury family of encoders

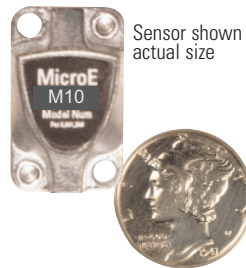

# Table Of Contents

<b>SYSTEM ILLUSTRATION</b>	<b>PAGE</b>
Encoder with Linear scale	2
Encoder with Rotary scale	3
<b>INSTALLATION INSTRUCTIONS</b>	
Encoder System Mounting - Linear	4
Encoder System Alignment - Linear	5
Centering the Index & Calibration - Linear	5
Encoder System Mounting - Rotary	6
Encoder System Alignment - Rotary	7
Centering the Index & Calibration - Rotary	7
<b>REFERENCE SECTION</b>	
Installation of Linear Scales	8
Grounding Instructions	9
Recommendations for Power	9
Recommended Interface Termination	9
Customer Interface Cable Requirements	10
SmartPrecision™ Module Mounting Options	11
Declaration of CE Conformance	11
<b>ENCODER TROUBLESHOOTING</b>	
Selected Topics	12
Cleaning Scales	12
Contact MicroE Systems	Back Cover

## Precautions



- 1 Follow standard ESD precautions. Turn power off before connecting the sensor. Do not touch the electrical pins without static protection such as a grounded wrist strap.
- 2 Do not touch the glass scale unless you are wearing talc-free gloves or finger cots. Please read this installation manual for full instructions.

### Safety Information

MicroE Systems Mercury series reflective encoders are classified as CDRH Class I and IEC Class 1M laser products.

- Invisible laser radiation (wavelength: 850 nm). Max power 1.5 mW CW.
- This product conforms to all applicable standards under 21 CFR Ch. I 1040.10.
- CDRH Class I level of laser radiation is not considered to be hazardous.
- CAUTION - The use of optical instruments with this product will increase eye hazard.
- DO NOT VIEW DIRECTLY WITH OPTICAL INSTRUMENTS (MICROSCOPES, EYE LOUPES OR MAGNIFIERS)
- CLASS 1M LASER PRODUCT
- IEC 60825-1 (2001)

## Patents

Covered by the following patents: US 5,991,249; EP 895,239; JP 3,025,237; US 6,897,435; and EP 1,451,933. Additional patents and patents pending may apply.



M2000 and M3000 are CE compliant. M3500 CE compliance is pending

# Mercury 2000, 3000 & 3500 Encoder System with Linear scale

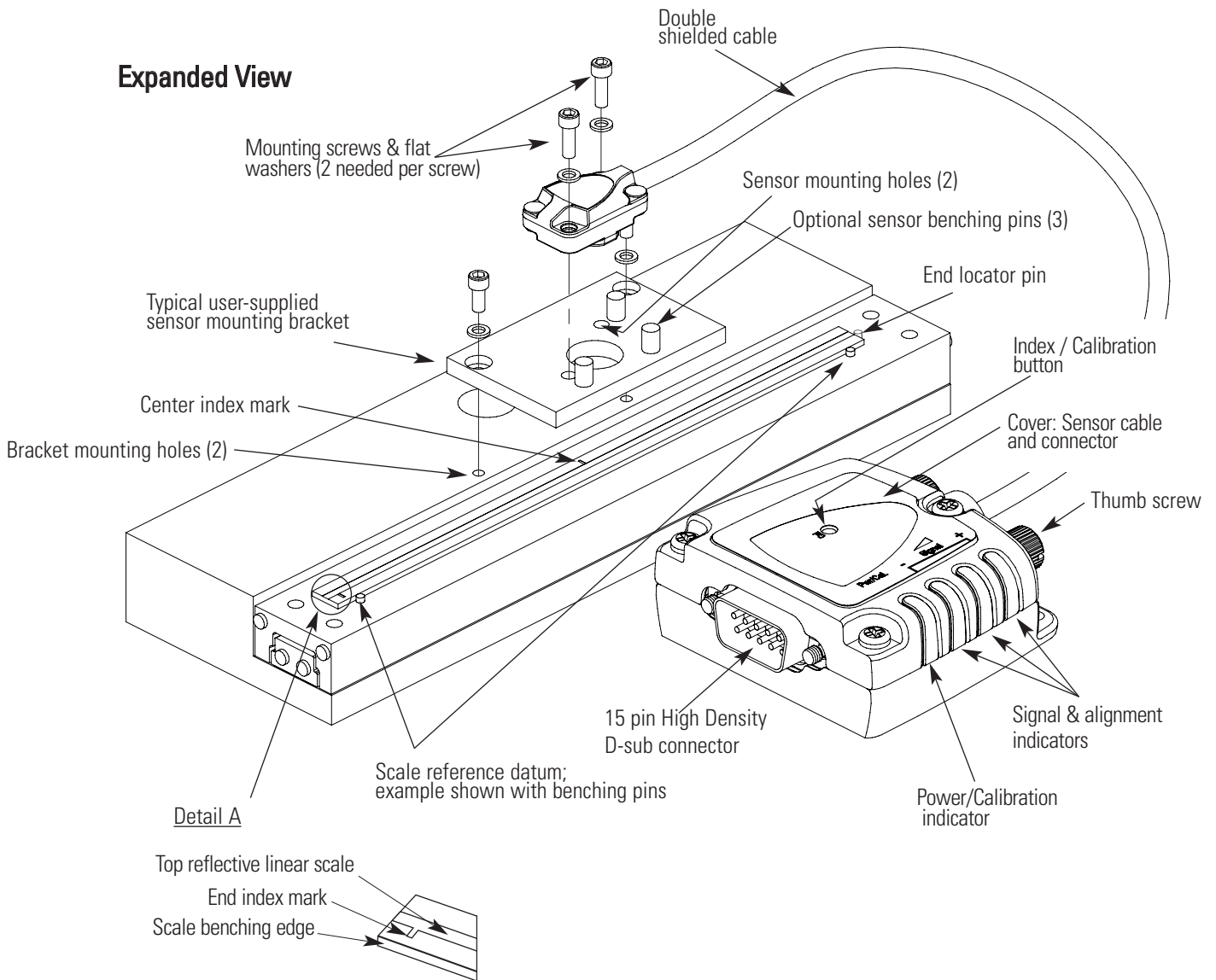
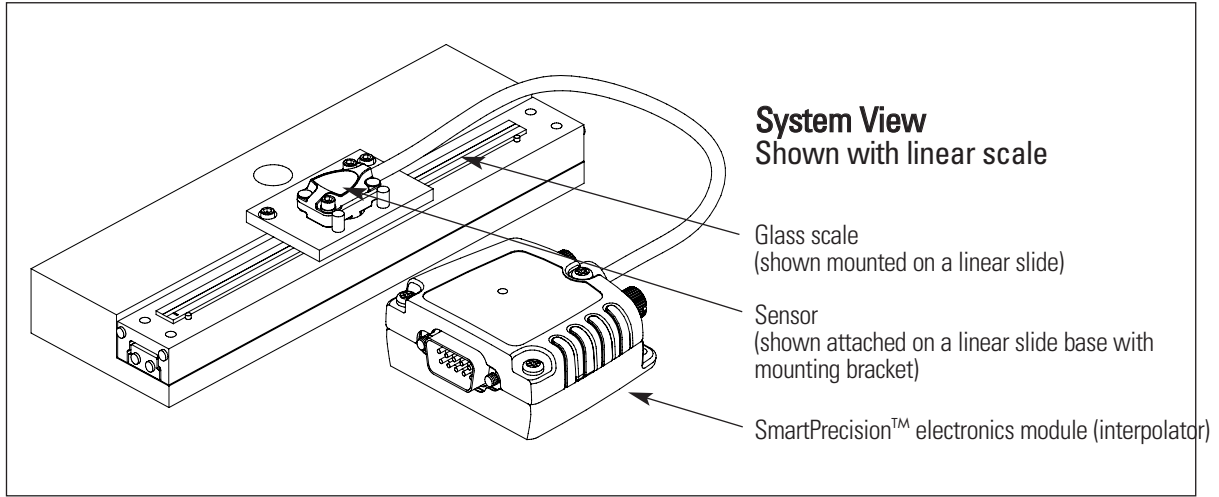

# Mercury 2000, 3000 & 3500 Encoder System with Rotary scale

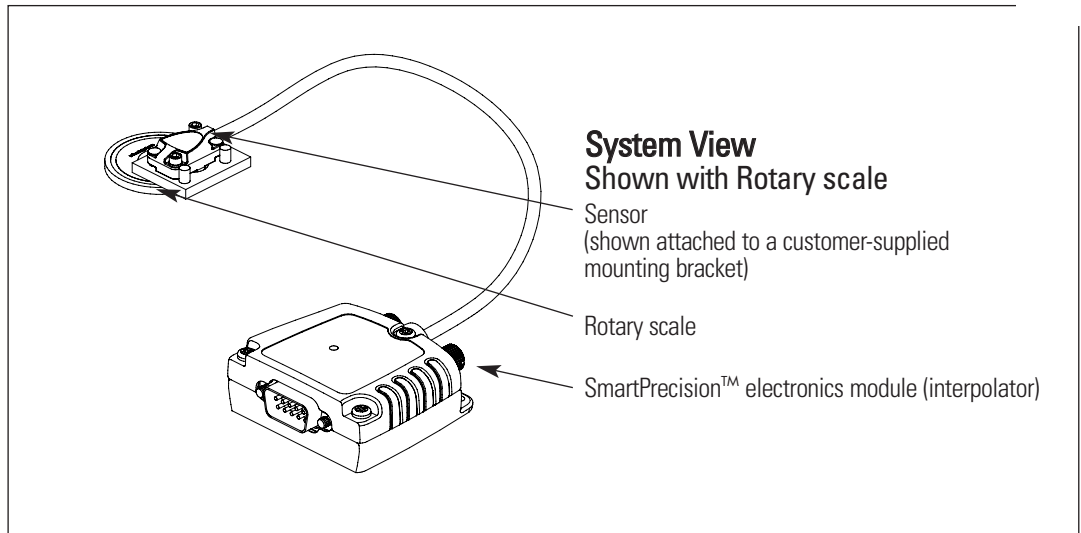

## Expanded View

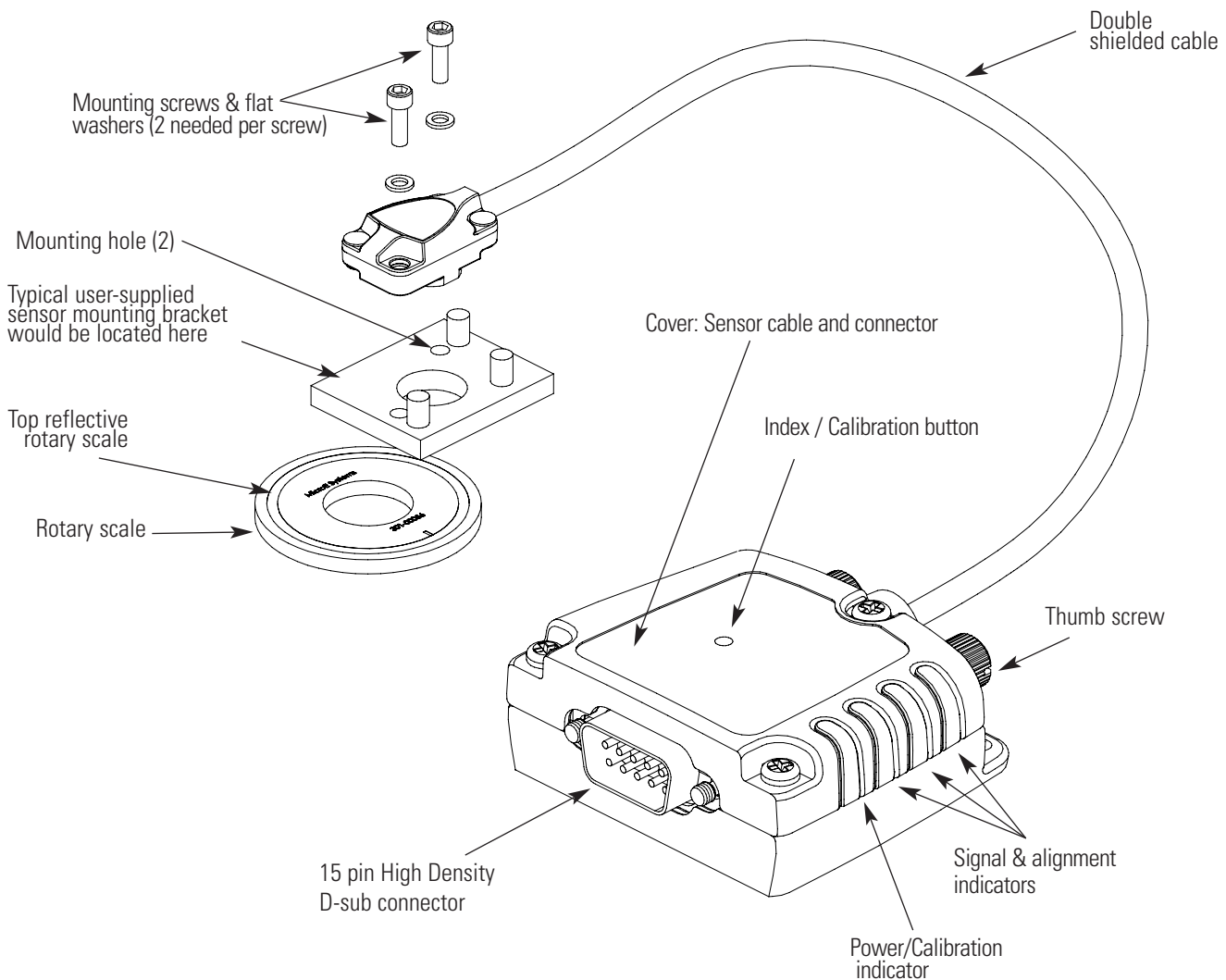

# Installation Instructions

## Linear Encoders

**1** Attach the scale to the base slide. Reference the preferred datum on the interface drawing for either end or center index orientation.

Depending on the mounting method, attach the scale to the slide with adhesive. Refer to pg. 8 for details.

Be sure the grating surface of the scale faces the sensor. Insure that there is no contact between these surfaces or damage may result.

Install the sensor on your mounting surface referencing the appropriate datum surface as shown on the interface drawing. Use 2 washers per mounting screw.

**2** Benching pins may be used to locate the sensor if the system mechanical tolerances are adequate. See data sheet for alignment tolerances, or keep mounting screws loose for sensor alignment if benching pins are not used.

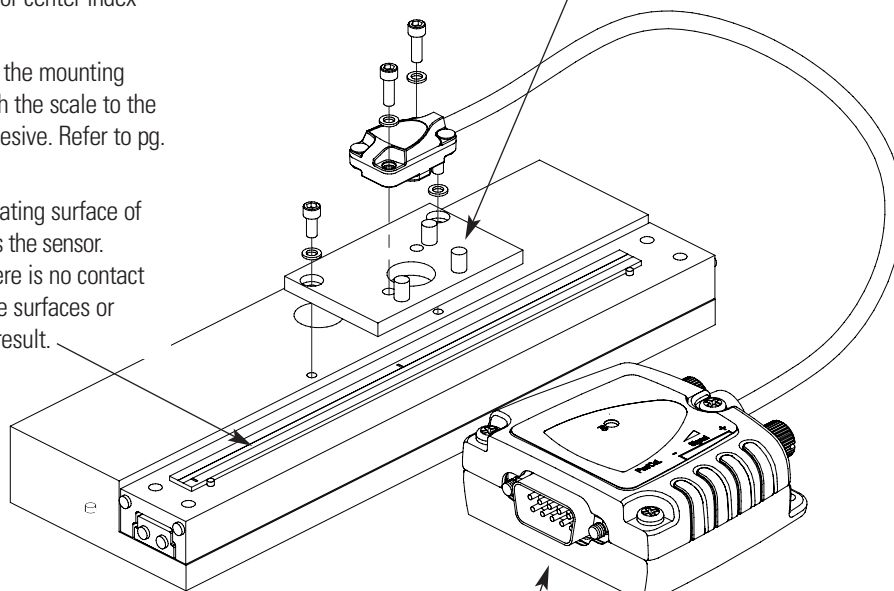

Be sure the source power is off before connecting the SmartPrecision plug.

Connect the SmartPrecision electronics to the controller using the pinout diagram described on the interface drawing.

**4** Pin 1 must not be connected under any circumstances, including connection to wires within extension cables and floating wires. Any connection to Pin 1 could damage or disable the encoder system.

Insure proper system grounding. Refer to the procedure on pg 9.

Tighten the thumb screws.

Power up the system. The Power/Calibration indicator will illuminate.

**CAUTION:** observe precautions for handling electrostatic sensitive devices.

Route the sensor cable through your equipment to the SmartPrecision electronics.

**3** A) Remove the three cover screws and the top half of the connector housing. Do not pull on the 15-pin D-sub connector or the circuit board under the insulation layer.

B) Attach the sensor's 5 X 2 connector to the mating 5 X 2 connector on the circuit board.

C) Route the sensor cable through its channel in the center of the connector body and place the cable's hex sleeve in the matching recess. Attach the top half of the connector housing to the bottom half using the three cover screws. The longest screw is used in the hole adjacent to the cable exit.

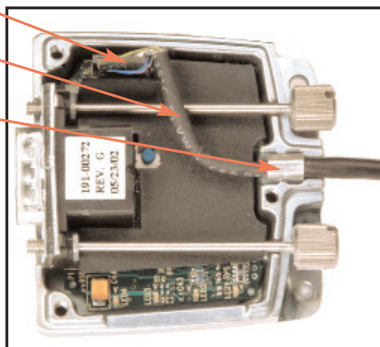

# Installation Instructions

## Linear Encoders

If benching dimensions cannot be provided, proper sensor alignment may require minor adjustments to the sensor position with respect to the scale. This can be performed easily using the LED alignment indicators, as illustrated below.

# 5

The red, yellow, or green LED will light depending on sensor alignment. Slowly move the sensor by allowing it to slide on the mounting surface until the green or Proper Alignment LED, is illuminated. Optimal alignment will be displayed as a "Bright Green" LED.

**IMPORTANT:** Confirm that the Proper Alignment LED blinks when passing over the index. If not, readjust the sensor in the Y direction and repeat the above procedure. When alignment is completed, tighten the sensor mounting screws (0.37Nm [3.3 inch-lbs.] maximum torque).

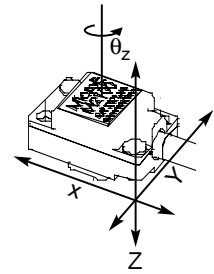

To align the sensor, move it in the Y or  $\theta_z$  directions.

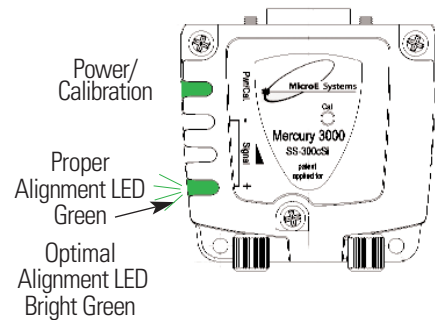
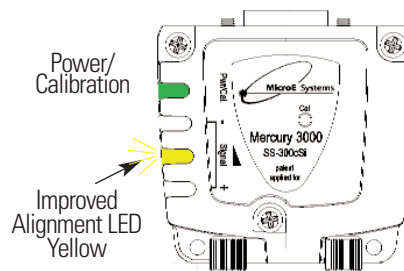
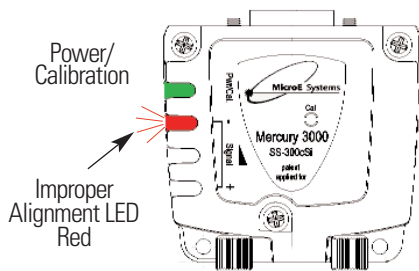

# 6

Confirm proper alignment over the full range of motion. The "Proper Alignment" LED must remain on over the entire range. If not aligned over the entire range of motion, loosen the sensor mounting screws and repeat step 5.

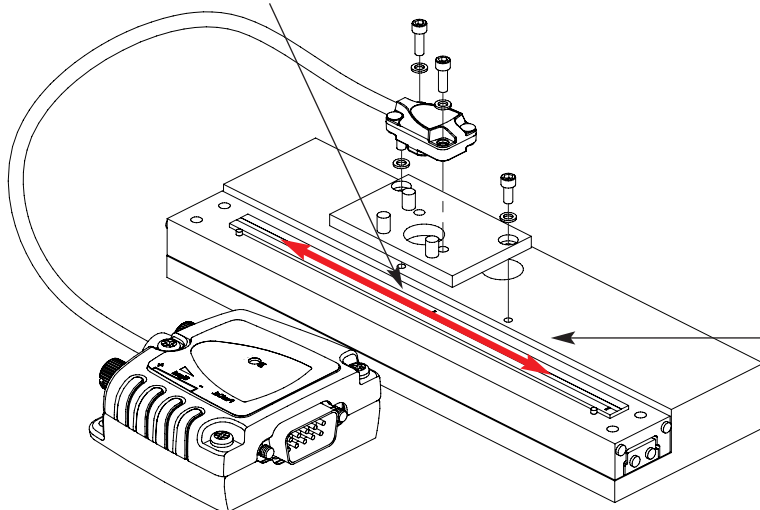

# 7

## **IMPORTANT** **OUTPUT CALIBRATION PROCEDURE**

This procedure must be completed for proper system operation each time the sensor is aligned or if the SmartPrecision™ electronics module is replaced.

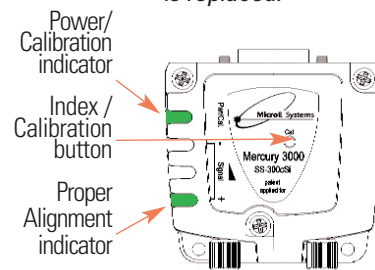

Position the sensor at least 7mm (1/4") away from the index mark on the scale. Next, push the Index/Calibration button inside the module with a

small diameter shaft, such as a bare cotton swab. The Power/Calibration indicator will flash continuously. Move the scale past the sensor in both directions so that the index mark passes under the sensor. Do not run off the end of the scale. When the calibration procedure is complete, the Power/Calibration indicator stops flashing.

# Installation Instructions

## Rotary Encoders

**1**

Attach your hub/scale assembly to the rotary device. Refer to the interface drawing. The reflective surface of the scale must face the sensor.

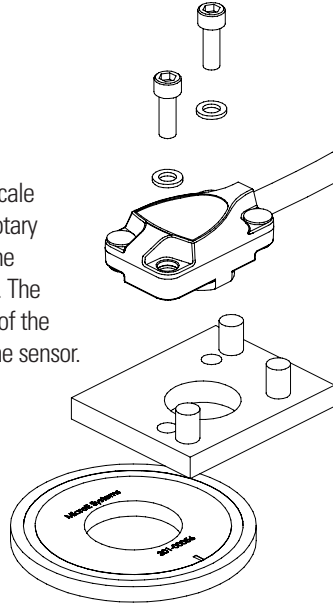

**2**

Install the sensor on your mounting surface referencing the appropriate datum surface as shown on the interface drawing. Use 2 washers per mounting screw.

Benching pins may be used to locate the sensor if the system mechanical tolerances are adequate. See data sheet for alignment tolerances, or keep mounting screws loose for sensor alignment if benching pins are not used.

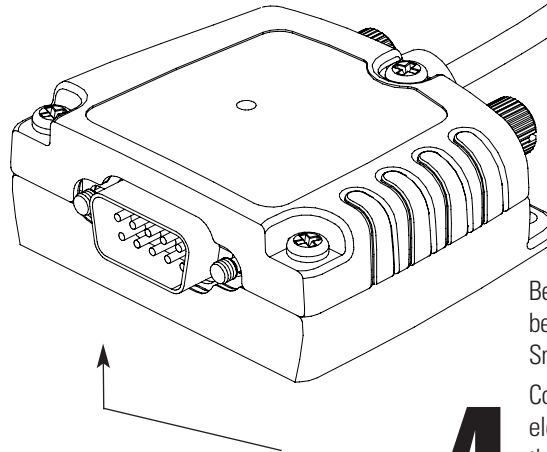

**4**

Be sure the source power is off before connecting the SmartPrecision plug.

Connect the SmartPrecision electronics to the controller using the pinout diagram described on the interface drawing.

Pin 1 must not be connected under any circumstances, including connection to wires within extension cables and floating wires. Any connection to Pin 1 could damage or disable the encoder system.

Insure proper system grounding. Refer to the procedure on pg 9.

Tighten the thumb screws.

Power up the system. The Power/Calibration indicator will illuminate.

**3**

CAUTION: observe precautions for handling electrostatic sensitive devices.

Route the sensor cable through your equipment to the SmartPrecision™ electronics.

- A) Remove the three cover screws and the top half of the connector housing. Do not pull on the 15-pin D-sub connector or the circuit board under the insulation layer.
- B) Attach the sensor's 5 X 2 connector to the mating 5 X 2 connector on the circuit board.
- C) Route the sensor cable through its channel in the center of the connector body and place the cable's hex sleeve in the matching recess. Attach the top half of the connector housing to the bottom half using the three cover screws. The longest screw is used in the hole adjacent to the cable exit.

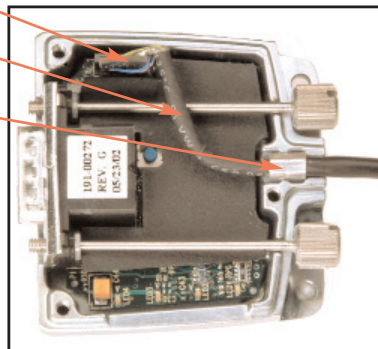

# Installation Instructions Rotary Encoders

If benching dimensions cannot be provided, proper sensor alignment may require minor adjustments to the sensor position with respect to the scale. This can be performed easily using the LED alignment indicators, as illustrated below.

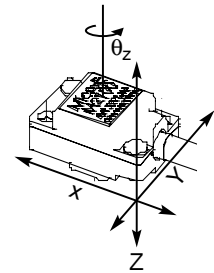

To align the sensor, move it in the Y or  $\theta_z$  directions.

**5** The red, yellow, or green LED will light depending on sensor alignment. Slowly move the sensor by allowing it to slide on the mounting surface until the green or Proper Alignment LED, is illuminated. Optimal alignment will be displayed as a "Bright Green" LED.

**IMPORTANT:** Confirm that the Proper Alignment LED blinks when passing over the index. If not, readjust the sensor in the Y direction and repeat the above procedure. When alignment is completed, tighten the sensor mounting screws (0.37Nm [3.3 inch-lbs.] maximum torque).

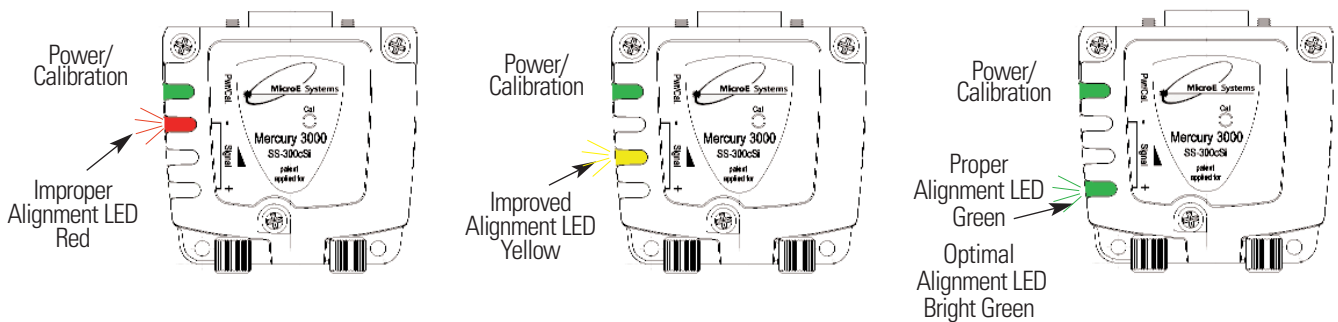

## **7** **IMPORTANT** **OUTPUT CALIBRATION PROCEDURE**

*This procedure must be completed for proper system operation each time the sensor is aligned or if the SmartPrecision electronics module is replaced.*

**6** Confirm proper alignment over the full range of motion. The "Proper Alignment" LED must remain on over the entire range of motion. If not aligned over the entire range of motion, loosen the sensor mounting screws and repeat step 5.

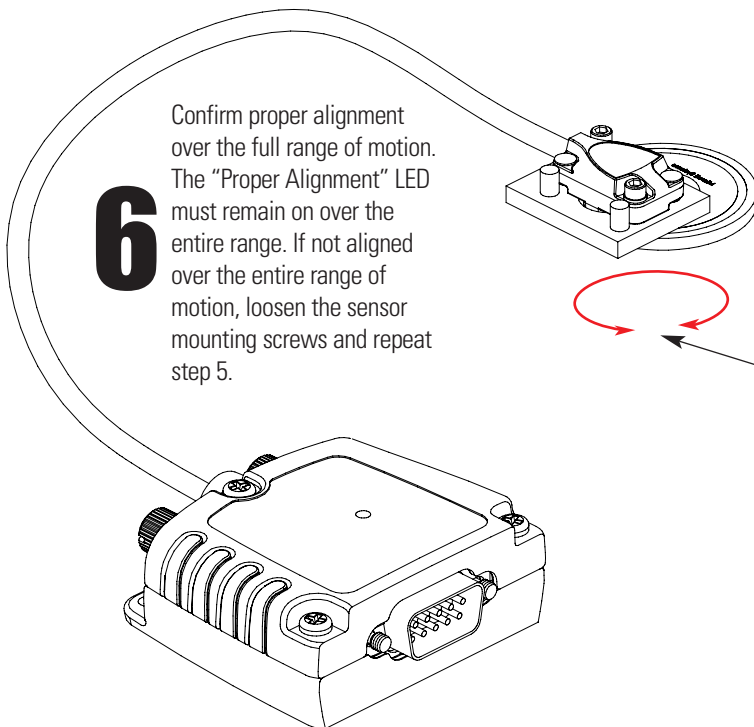

Power/  
Calibration  
indicator  
Index/  
Calibration  
button  
Proper  
Alignment  
indicator

Position the sensor at least 7mm (1/4") away from the index mark on the scale. Next, push the Index/Calibration button inside the module with a small diameter shaft, such as a bare cotton swab.

The Power/Calibration indicator will flash continuously. Move the scale past the sensor in both directions so that the index mark passes under the sensor. Do not run off the end of the scale when using a segment scale. When the calibration procedure is complete, the Power/Calibration indicator stops flashing.

# Reference Section

## Installation of Linear Scales

### Positioning the Scale

Note: Before beginning mounting procedure, use talc-free gloves or finger cots to handle the scales.

"Benching" the scale to the system means aligning the scale by means of benching pins. Pin locations are described on the appropriate interface drawing. Two benching pins are recommended on the long side of the scale and one at the end as shown. This is marked datum A on the interface drawing.

**1** Position the benching pins in from either end. 20% of the overall scale length is the recommended location from the edge.

**2** Be sure the benching pins do not extend too high in the Z direction to prevent mechanical interference with the sensor or sensor mount.

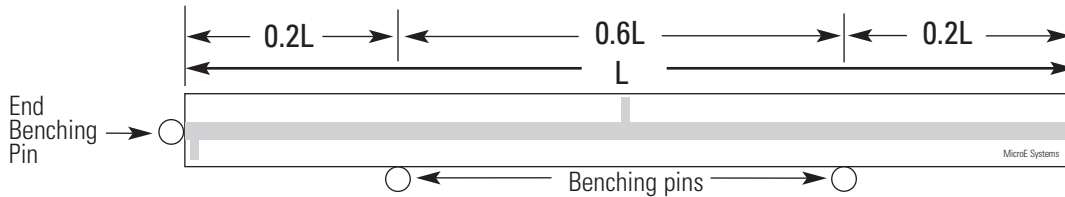

### Mounting the Scale

MicroE Systems' linear scales should be affixed to the mounting surface. Two different approaches are described below:

#### Epoxy and RTV Mounting (Recommended for best accuracy)

**1** Make sure the mounting surface is clean and dry.

**3** Optionally, scale clamps may be used to secure the scale while the adhesive cures. Avoid damage to the top surface.

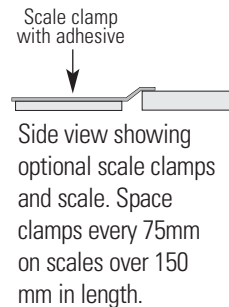
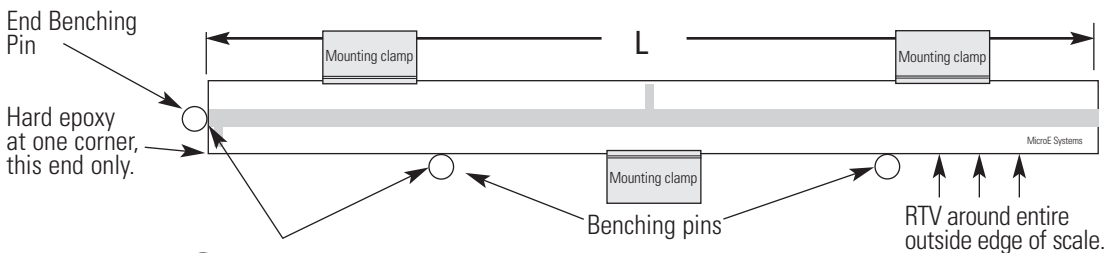

**2** Align the scale by placing the edges against the benching pins.

**4** Apply a hard epoxy, such as Tra-Con's Tra-Bond 2116, to the end of the scale at the end benching pin. Apply 100% Silicone RTV adhesive around the edges of the scale. This method allows thermal expansion from the benched end of the scale. After adhesive curing, remove the scale mounting clamps or, if permanently installing clamps, make sure they do not interfere with the sensor or sensor mount.

#### Two Sided Adhesive Tape Mounting

**1** Make sure the mounting surface is clean and dry. Peel the cover paper off and place the scale above the final location.

**3** Gently place the scale on the mounting surface. Positioning adjustments can be made until the scale is firmly pressed down. After final positioning, push down on the top of the scale to secure it.

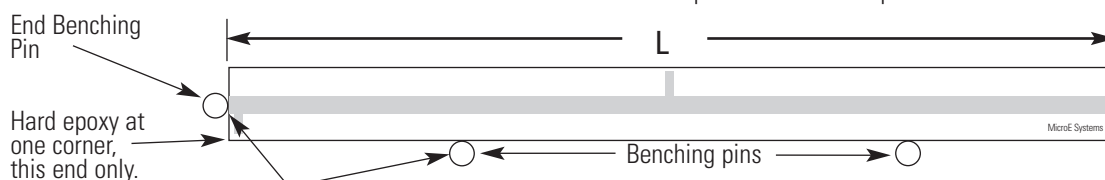

**2** Align the scale by placing the edges against the benching pins.

## Grounding Instructions for Mercury 2000, 3000 and 3500 Encoder Systems

For Mercury 2000 and 3000 encoder systems to operate reliably, it is essential that the sensor and cable shield are grounded properly according to the following instructions. The diagrams below show how to make the connections when the encoder's connector is plugged into the customer's controller chassis. If a customer-supplied extension cable is used, it should be a double shielded cable with conductive connector shells and must provide complete shielding over the conductors contained within it over its entire length. Furthermore, the shields should be grounded at the connection to the controller chassis the same way as the encoder connectors in the diagrams below.

Note: For best performance, isolate encoder shield from motor cable shields and separate encoder cable as far possible from motor cables.

### Sensor mounted with good electrical contact to a well-grounded surface (preferred)

- 15-pin D-sub connector grounding: The encoder's connector shell must be in intimate, electrically conductive contact with the customer-supplied mating connector, which must be isolated from the controller's ground. If a customer-supplied shielded cable connects the encoder to the controller, then the shielding on the customer-supplied cable must be isolated from the controller's ground.
- The sensor mounting surface must have a low impedance (DC/AC) connection to ground. The encoder sensor mounting surface may have to be masked during painting or anodizing to insure good electrical contact with the sensor.

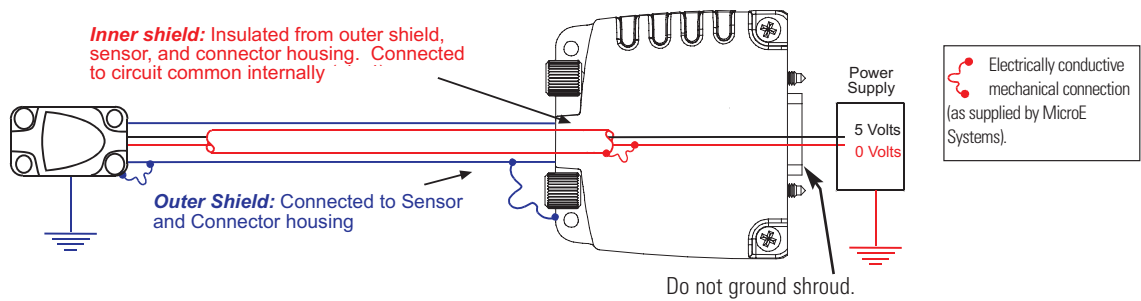

### Sensor mounted to a surface that is grounded through bearings or a poorly-grounded surface, or a non-conducting surface

- 15-pin D-sub connector grounding: The encoder's connector shell must be in intimate, electrically conductive contact with the customer-supplied mating connector, which must be connected to the controller's ground. If a customer-supplied shielded cable connects the encoder to the controller, then the shielding on the customer-supplied cable must be connected to the controller's ground. The controller must be grounded to earth at the point of installation.
- The encoder sensor must be mounted so that it is electrically isolated from ground.

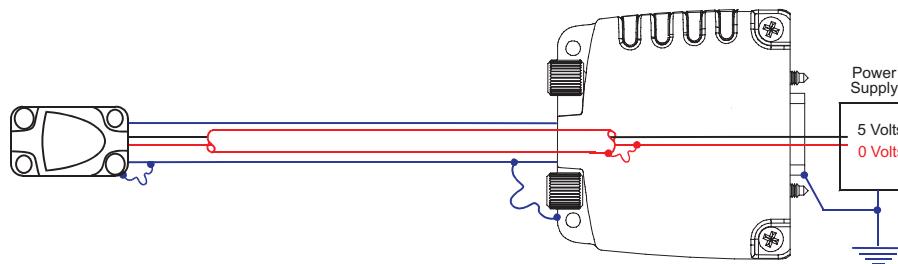

## Recommendations for Power

Mercury encoders require a minimum of 4.75V DC continuously. When designing circuits and extension cables to use Mercury encoders, be sure to account for voltage loss over distance and tolerances from the nominal supply voltage so that at least 4.75V DC is available to the Mercury encoder under all operating conditions. The input voltage should not exceed 5.25V DC.

## Recommended Interface Termination

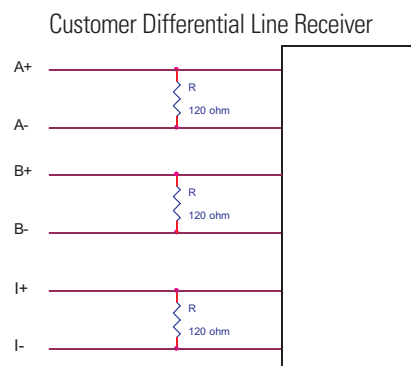

### Customer Interface Cable Requirements

Customer cables that interface to Mercury series encoders must have the following characteristics:

- Twisted pair signal wiring.
- Characteristic impedance of 100-120 ohms.
- Sufficient wire gauge to meet the minimum voltage requirement at the encoder, for example 24AWG gauge wire for a 2m length cable. Examples of acceptable cables with 24 AWG gauge wire and 4 twisted pairs are Belden 9831, 8104, and 9844 or other manufacturer's equivalents.
- Single shield cable with a minimum of 90% coverage. Note that a double shielded cable may be required in high-noise applications.

### Signal Wiring:

Each differential signal should be connected to a corresponding twisted pair as follows:

Mercury 3500, 3000, 2000	
Signal	Twisted Pair
A+	Pair 1
A-	
B+	Pair 2
B-	
Index+	Pair 3
Index-	
+5V	Pair 4
GND	

### Shield Termination:

The customer's cable shield should be in 360° contact with the connector shroud and the connector shell to provide complete shielding. The connector shell should be metal with conductive surfaces. Suggested metal connector shells for use with Mercury 3500, 3000, 3000Si, and 2000 encoders: AMP 748676-1 or equivalent; for Mercury 1000 and 1500S encoders: AMP 745172-3, -2, or -1 where the dash number is dependent on the customer's outside cable diameter. The shield should be terminated as illustrated in the following diagram.

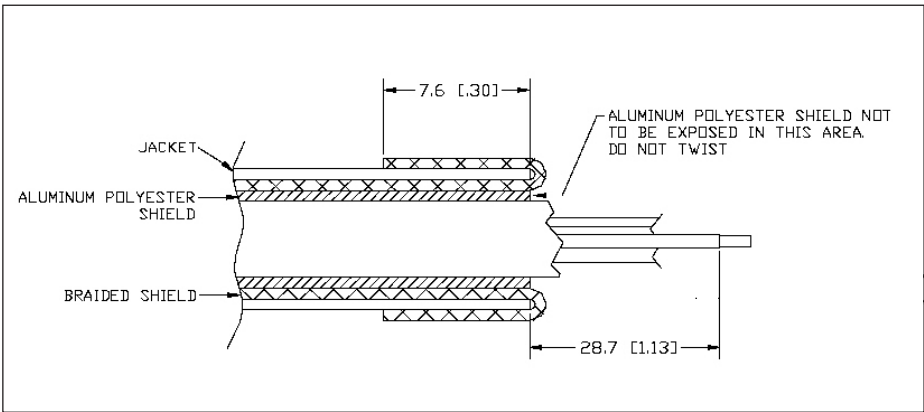

Fold braided shield back over jacket. Example shows double-shielded cable. Dimensions shown are for illustration only.



## Problem

***The Power/Calibration indicator will not come on.***

## Solution

- Make sure that the SmartPrecision™ electronics' 15-pin D-sub connector is fully seated and connected.
- Confirm that +5 Volts DC is being applied to pin 12 on the SmartPrecision™ electronics' 15-pin HD connector and that pin 13 is connected to ground.

## Problem

***Can't get the SmartPrecision™ electronics' "Signal" LEDs better than red or yellow; or the green, " Proper Alignment" indicator doesn't stay illuminated over the full length of the scale.***

## Solution

- Verify that the sensor has been aligned to the scale and that the mounting screws are tight. Check the dimensions for the mechanical mounting holes (and clamps if any) to make sure that the sensor is correctly located over the scale. Refer to appropriate the interface drawing.
- Check that the scale is firmly mounted and can't jiggle or move in other than the intended direction.
- Make sure that the scale is clean over its entire length or circumference.

## Problem

***The green Power/Calibration indicator is flashing unexpectedly.***

## Solution

- Part of the normal setup procedure is to activate the SmartPrecision™ electronics' Index/Calibration process by pressing the recessed button the SmartPrecision™ electronics' connector body. The On/Index LED will begin to flash until the index mark on the scale passes under the sensor at least one time in each direction.

## Problem

***Can't Complete the Index/Calibration process - the green Power/Calibration indicator doesn't stop flashing.***

## Solution

- Verify that the sensor is mounted in the correct orientation to the scale for the desired index mark. Refer to the interface drawing.
- Refer to step 5 of the installation procedure to insure proper operation.

## Cleaning scales



### General Particle Removal

Blow off the contamination with nitrogen, clean air, or a similar gas.

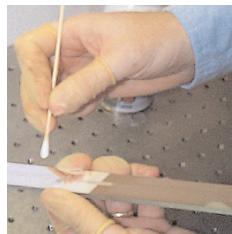

### Contamination Removal

Use a lint-free clean-room wipe or cotton swab dampened with isopropyl alcohol or acetone only to wipe the surface clean. Handle the scale by the edges. Do not scrub the scale.

# Contacting MicroE Systems

Thank you for purchasing a MicroE Systems product. You should expect the highest level of quality and support from MicroE. If you want to download the Mercury Encoder Installation Manual, Data Sheet or Interface Drawing, browse [www.microesys.com](http://www.microesys.com) and click on the Mercury Encoders button.

