

Mercury™ 1500S

Digital Output Encoder Systems

*Installation Manual
and Reference Guide*

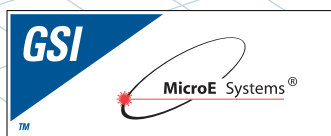

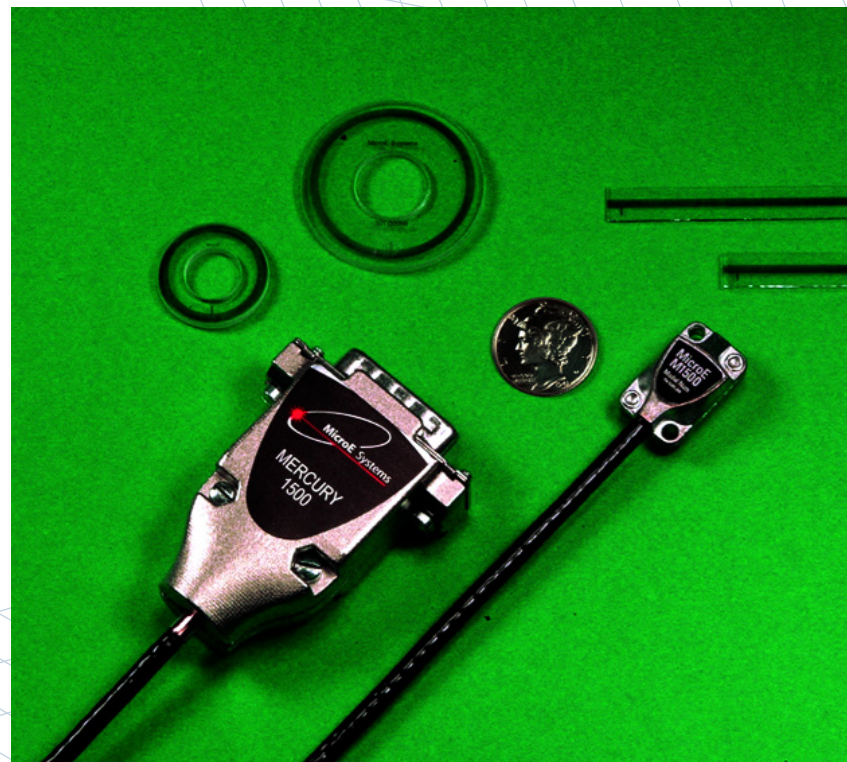
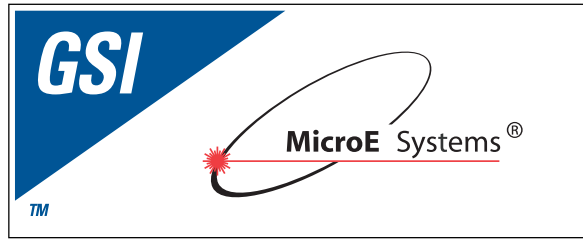

MicroE Systems was founded to advance encoder technology to a level never before achieved. Our objective was to design encoder systems that would be small enough to fit into densely packed OEM equipment designs, affordable enough for cost-sensitive applications and easy enough to enable installation, setup and alignment by assemblers with little training. We are pleased to say that all of these goals have been realized with the introduction of the Mercury family of encoders

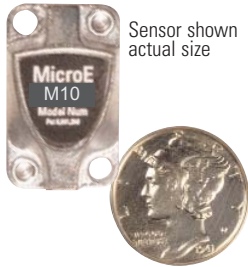

Table Of Contents

SYSTEM ILLUSTRATION	PAGE
Encoder with Linear scale	2
Encoder with Rotary scale	3
INSTALLATION INSTRUCTIONS	
Using SmartPrecision Alignment Tool - Linear Scales	
Mounting Encoder System	4
Alignment of Encoder System	5
Using SIN/COS Signals - Linear Scales	
Mounting Encoder System	6
Alignment of Encoder System	7
Establishing an Index	7
Using SmartPrecision Alignment Tool - Rotary Scales	
Mounting Encoder System	8
Alignment of Encoder System	9
Using SIN/COS Signals - Rotary Scales	
Mounting Encoder System	10
Alignment of Encoder System	11
Establishing an Index	11
REFERENCE SECTION	
Installation of Linear Scales	12
Grounding Instructions	13
Recommendations for Power	13
Customer Interface Cable Requirements	14
Output Signal description	15
ENCODER TROUBLESHOOTING	
Selected Topics	16
Cleaning Scales	16
Contact MicroE Systems	Back Cover

Precautions



- 1 Follow standard ESD precautions. Turn power off before connecting the sensor. Do not touch the electrical pins without static protection such as a grounded wrist strap.
- 2 Do not touch the glass scale unless you are wearing talc-free gloves or finger cots. Please read this installation manual for full instructions.

Safety Information

MicroE Systems Mercury series reflective encoders are classified as CDRH Class I and IEC Class 1M laser products.

- Invisible laser radiation (wavelength: 850 nm). Max power 1.5 mW CW.
- This product conforms to all applicable standards under 21 CFR Ch. I 1040.10.
- CDRH Class I level of laser radiation is not considered to be hazardous.
- CAUTION - The use of optical instruments with this product will increase eye hazard.
- DO NOT VIEW DIRECTLY WITH OPTICAL INSTRUMENTS (MICROSCOPES, EYE LOUPES OR MAGNIFIERS)
- CLASS 1M LASER PRODUCT
- IEC 60825-1 (2001)

Patents

Covered by the following patents: US 5,991,249; EP 895,239; and JP 3,025,237. Additional patents and patents pending may apply.

Mercury 1500S Encoder System with Linear scale

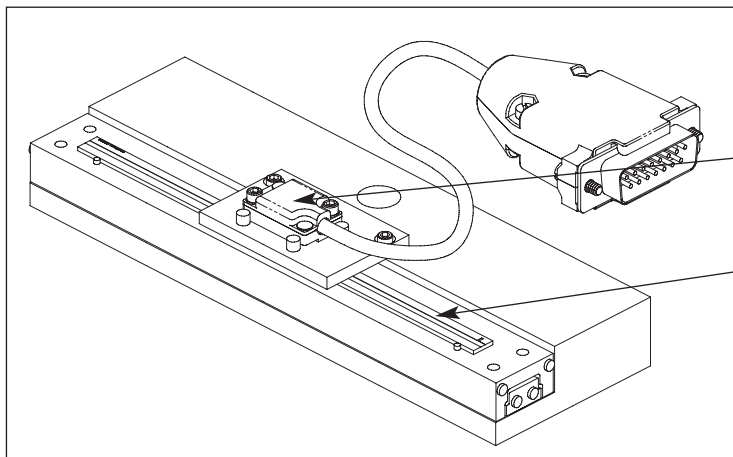

System View Shown with linear scale

Sensor
(shown attached on a linear slide base with
mounting bracket)

Glass scale
(shown mounted on a linear slide)

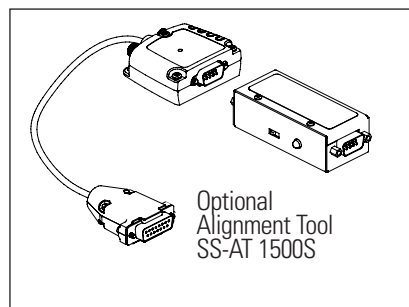

Optional
Alignment Tool
SS-AT 1500S

Expanded View

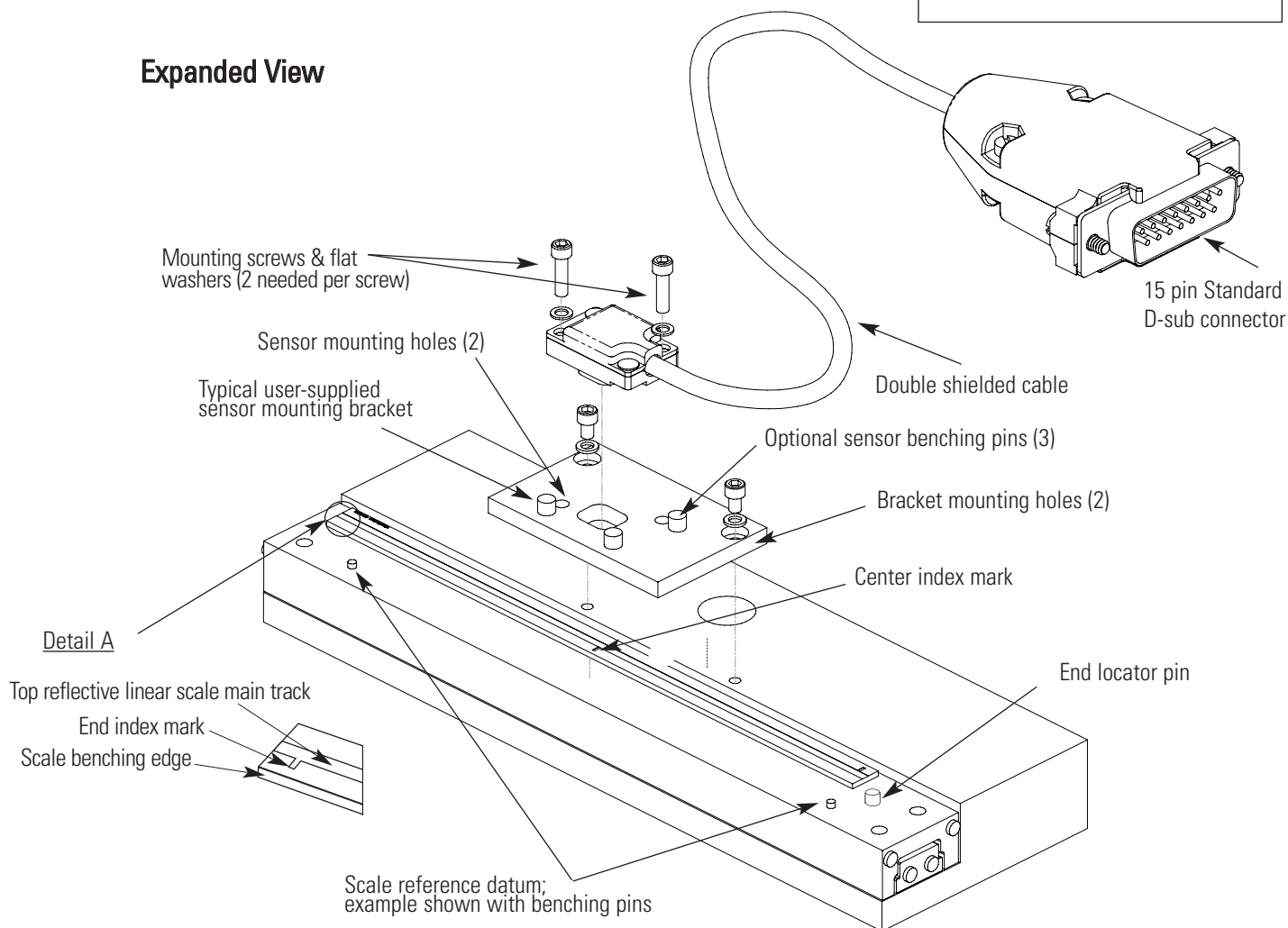

Mercury 1500S Encoder System with Rotary scale

System View Shown with rotary scale

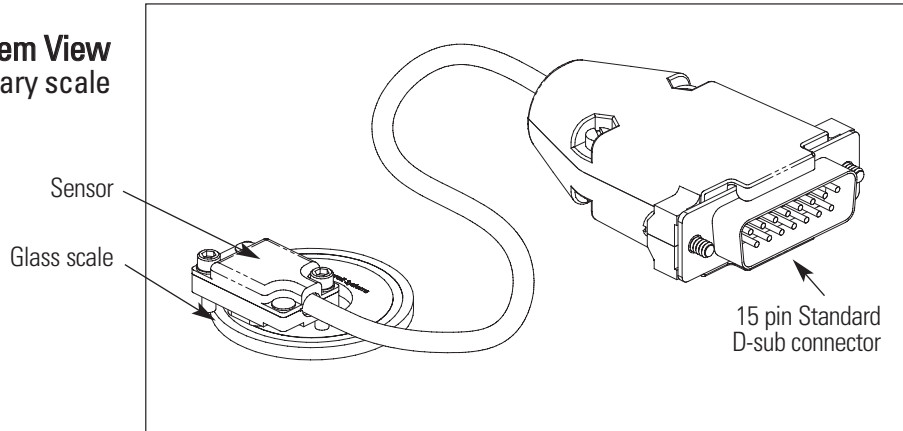

Expanded View

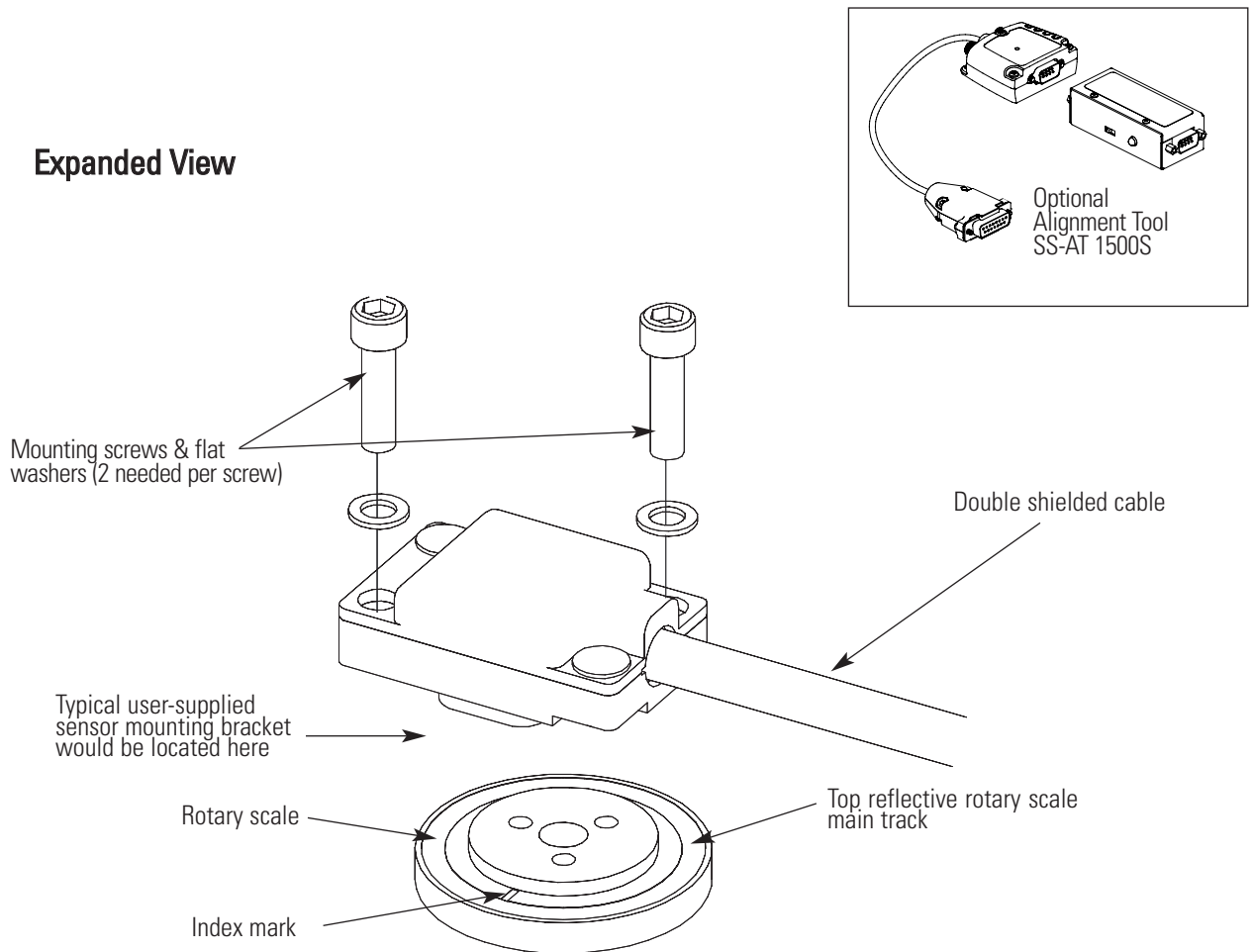

Installation Instructions

Linear Encoders - Using Alignment Tool - Mounting

1 Attach the scale to the base slide. Reference the preferred datum on the interface drawing for either end or center index orientation.

Depending on the mounting method, attach the scale to the slide with adhesive. Refer to pg. 12 for details.

Be sure the grating surface of the scale faces the sensor. Insure that there is no contact between these surfaces or damage may result.

2 Install the sensor on your mounting surface referencing the appropriate datum surface as shown on the interface drawing. Use 2 washers per mounting screw.

Benching pins may be used to locate the sensor if the system mechanical tolerances are adequate. See data sheet for alignment tolerances, or keep mounting screws loose for sensor alignment if benching pins are not used.

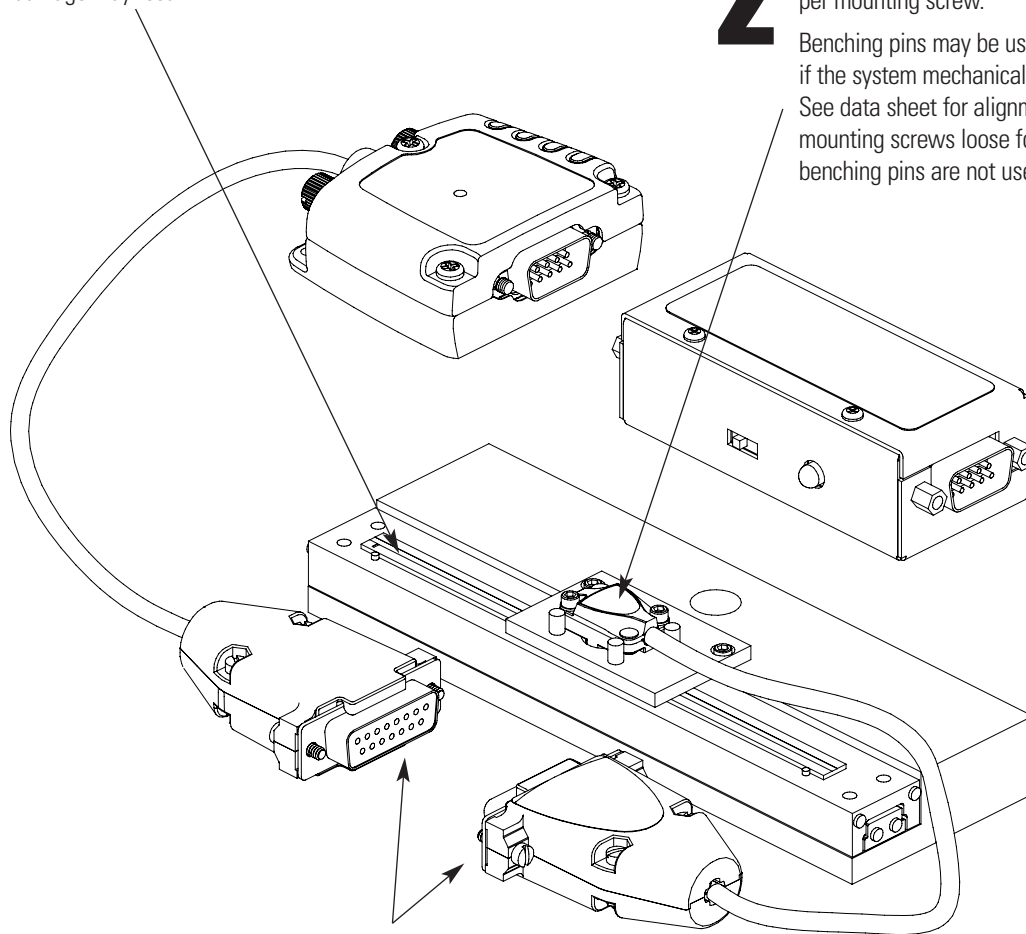

3 Be sure the source power is off before connecting the SmartPrecision Alignment Tool. Connect the M1500S to the SmartPrecision Alignment Tool

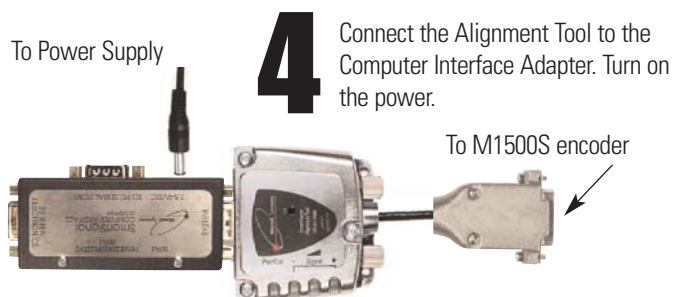

Installation Instructions

Linear Encoders - Using Alignment Tool - Alignment

5

Proper sensor alignment may require minor adjustments to the sensor position with respect to the scale. This can be performed easily using the optional SmartPrecision Alignment Tool as illustrated below.

The red, yellow, or green LED will light depending on sensor alignment. Slowly move the sensor by allowing it to slide on the mounting surface until the green LED, is illuminated. Optimal alignment will be displayed as a "Bright Green" LED.

IMPORTANT: Confirm that the green LED blinks when passing over the index. If not, readjust the sensor in the Y direction and repeat the above procedure. When alignment is completed, tighten the sensor mounting screws (0.37Nm [3.3 inch-lbs.] maximum torque).

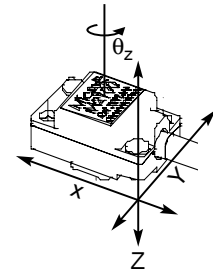

To align the sensor, move it in the Y or θ_z directions.

SmartPrecision
Alignment Tool

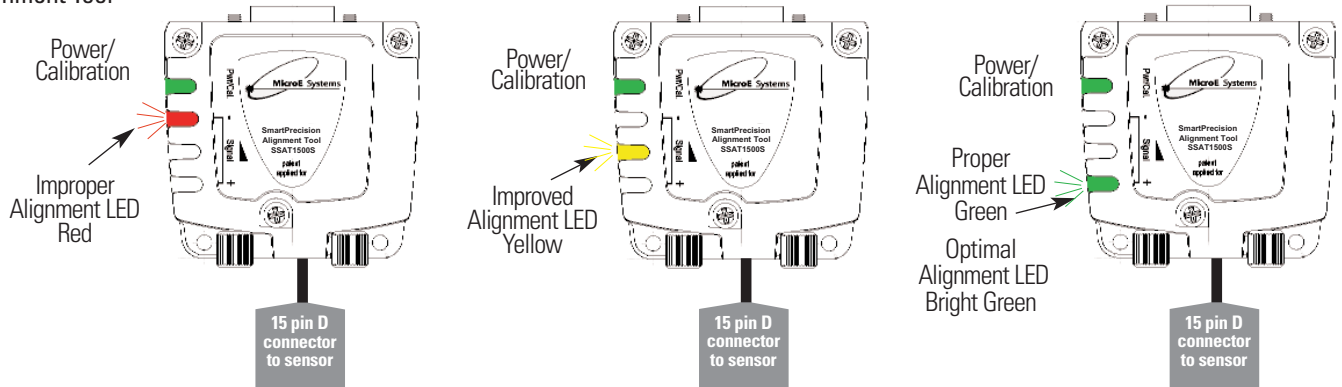

6

Confirm green over the full range of motion by sliding the scale past the sensor. The "green" LED must remain on over the entire range. If not aligned over the entire range of motion, loosen the sensor mounting screws and repeat step 5.

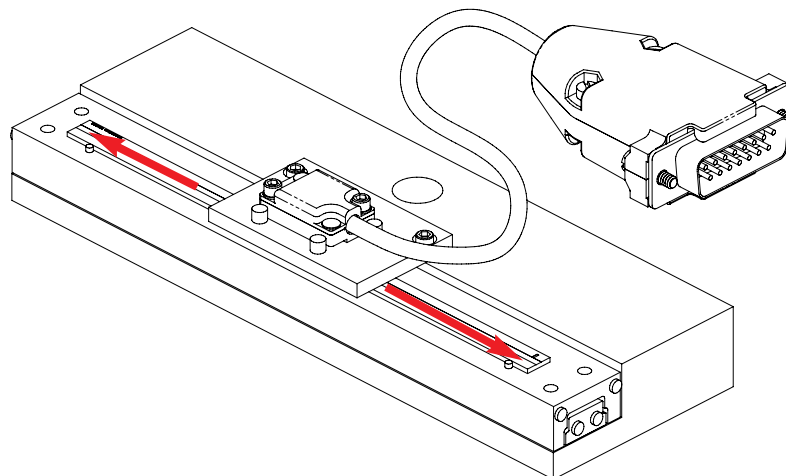

Installation Instructions

Linear Encoders - Using Sin/Cos Signals - *Mounting*

1 Attach the scale to the base slide. Reference the preferred datum on the interface drawing for either end or center index orientation.

Depending on the mounting method, attach the scale to the slide with adhesive. Refer to pg. 12 for details.

Be sure the grating surface of the scale faces the sensor. Insure that there is no contact between these surfaces or damage may result.

2 Install the sensor on your mounting surface referencing the appropriate datum surface as shown on the interface drawing. Use 2 washers per mounting screw.

Benching pins may be used to locate the sensor if the system mechanical tolerances are adequate. See data sheet for alignment tolerances, or keep mounting screws loose for sensor alignment if benching pins are not used.

Be sure power is off before connecting the sensor.

3 Connect the M1500S to your interface electronics using the pinout diagram described on the interface drawing.

Tighten the connector screws.

Power up the system.

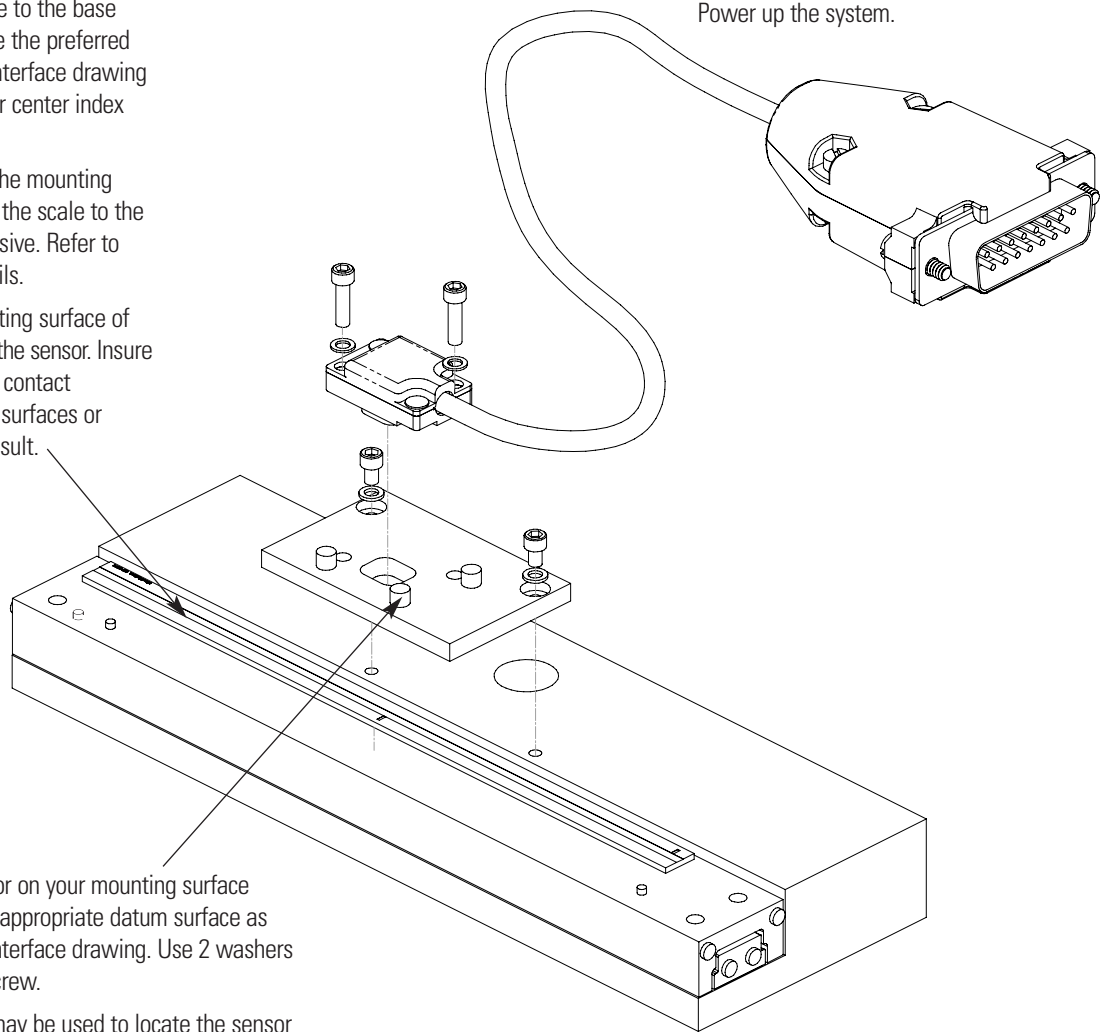

Installation Instructions

Linear Encoders - Using Sin/Cos Signals - Alignment

4

MAIN TRACK ALIGNMENT

If benching dimensions cannot be provided, proper sensor alignment may require minor adjustments to the sensor position with respect to the scale. This can be performed by maximizing the sine signal from the M1500S.

Using an oscilloscope, monitor the sine or cosine signal (refer to the interface drawing for pinouts) while moving the sensor over the scale. Align the sensor until 0.8 volts peak-to-peak +/- 25% is obtained. When alignment is completed, tighten the sensor mounting screws (0.37Nm [3.3 inch-lbs.] maximum torque).

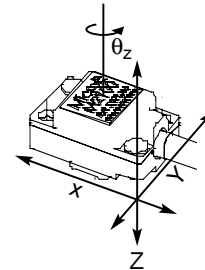

To align the sensor, move it in the Y or θ_z directions.

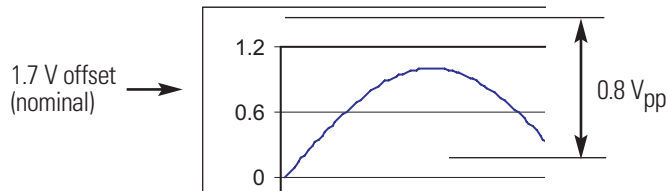

5

INDEX TRACK ALIGNMENT

The M1500S must be aligned for both the main and index tracks. When properly aligned, the sensor will produce an index window as the sensor passes over the index mark. The index window is approximately one fringe wide (20 μ m). To verify proper index track alignment, use a digital oscilloscope triggered on the index window. Refer to the interface drawing for the index window pinout.

Confirm proper alignment of the main track over the full range of motion. If not aligned over the entire range of motion, loosen the sensor mounting screws and repeat steps 4 and 5.

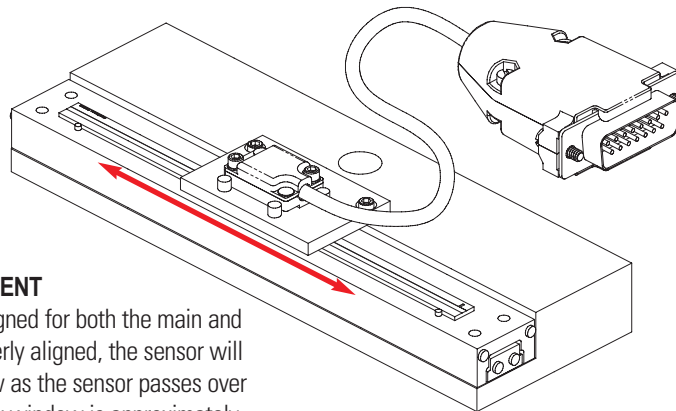

Installation Instructions

Rotary Encoders - Using Alignment Tool - *Mounting*

1 Attach your hub/scale assembly to the rotary device. Refer to the interface drawing. The reflective surface of the scale must face the sensor.

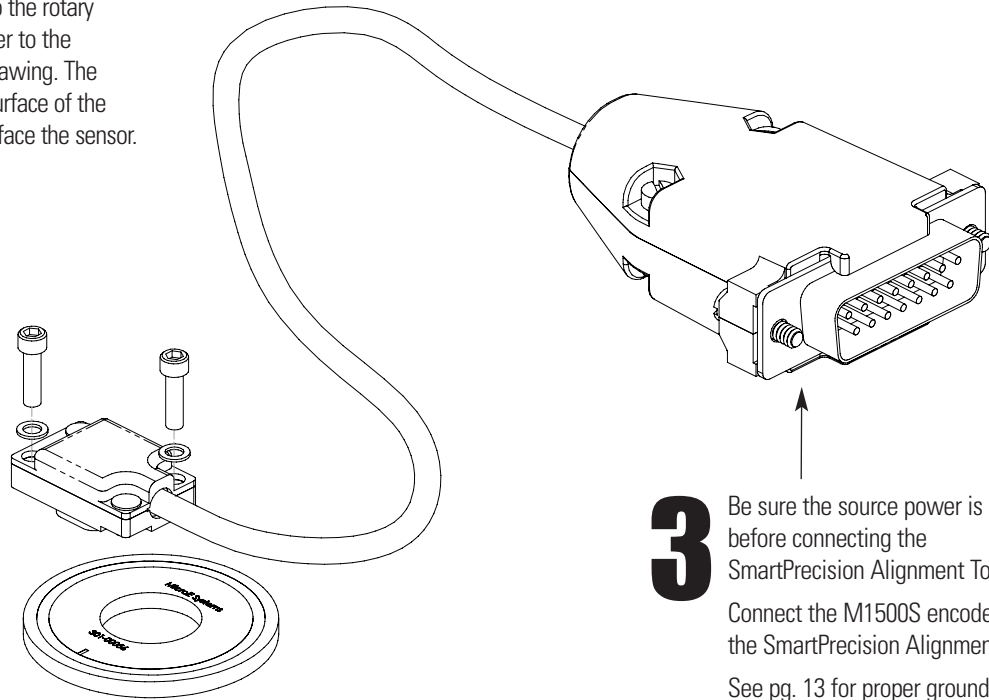

3 Be sure the source power is off before connecting the SmartPrecision Alignment Tool. Connect the M1500S encoder to the SmartPrecision Alignment Tool. See pg. 13 for proper grounding.

2 Install the sensor on your mounting surface referencing the appropriate datum surface as shown on the interface drawing. Use 2 washers per mounting screw.

Benching pins may be used to locate the sensor if the system mechanical tolerances are adequate. See data sheet for alignment tolerances, or keep mounting screws loose for sensor alignment if benching pins are not used.

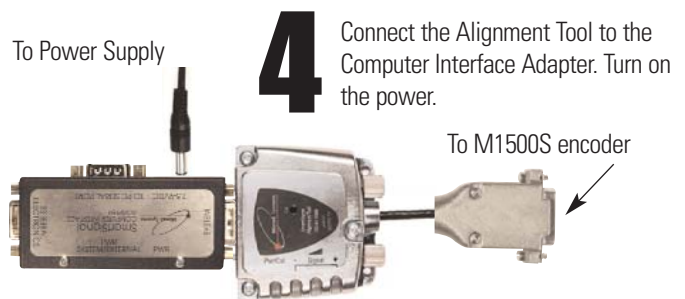

4 Connect the Alignment Tool to the Computer Interface Adapter. Turn on the power.

Installation Instructions

Rotary Encoders - Using Alignment Tool - Alignment

Proper sensor alignment may require minor adjustments to the sensor position with respect to the scale. This can be performed easily using the SmartPrecision Alignment Tool as illustrated below.

5

The red, yellow, or green LED will light depending on sensor alignment. Slowly move the sensor by allowing it to slide on the mounting surface until the green LED, is illuminated. Optimal alignment will be displayed as a "Bright Green" LED.

IMPORTANT: Confirm that the green LED blinks when passing over the index. If not, readjust the sensor in the Y direction and repeat the above procedure. When alignment is completed, tighten the sensor mounting screws (0.37Nm [3.3 inch-lbs.] maximum torque).

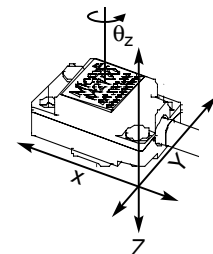

To align the sensor, move it in the Y or θ_z directions.

SmartPrecision Alignment Tool

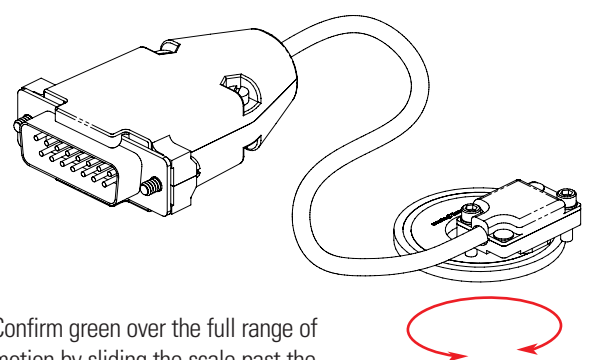
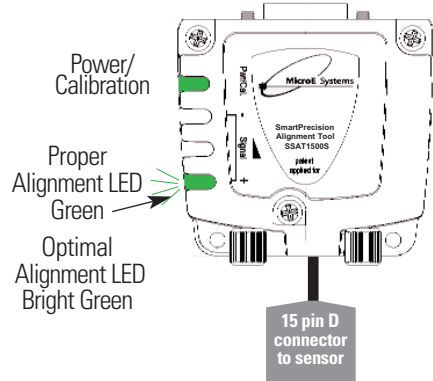
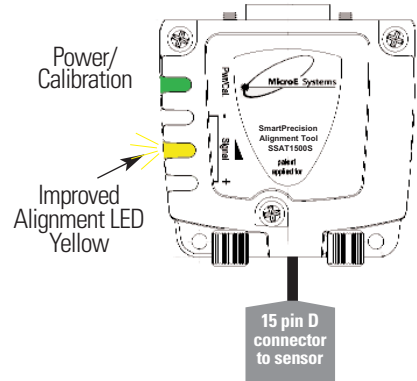
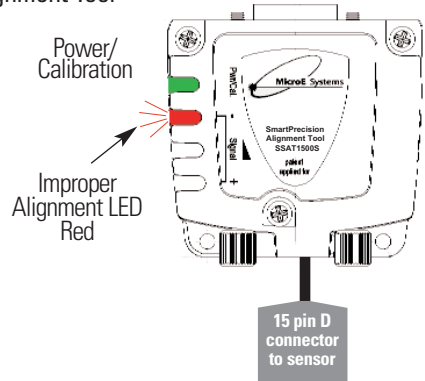

6

Confirm green over the full range of motion by sliding the scale past the sensor. The "green" LED must remain on over the entire range. If not aligned over the entire range of motion, loosen the sensor mounting screws and repeat step 5.

Installation Instructions

Rotary Encoders - Using Sin/Cos Signals - *Mounting*

1 Attach your hub/scale assembly to the rotary device. Refer to the interface drawing. The reflective surface of the scale must face the sensor.

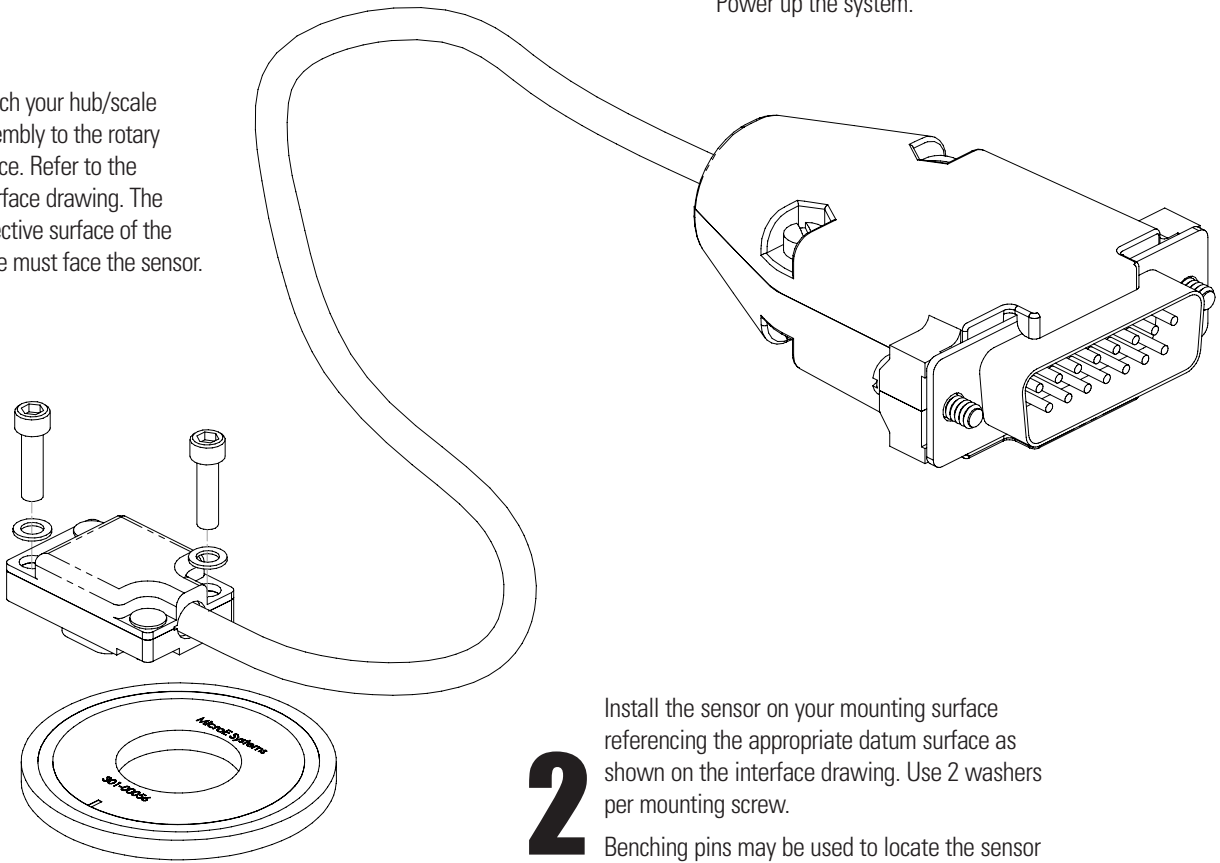

3 Be sure power is off before connecting the sensor.
Connect the M1500S to your interface electronics using the pinout diagram described on the interface drawing.
Tighten the connector screws.
Power up the system.

2 Install the sensor on your mounting surface referencing the appropriate datum surface as shown on the interface drawing. Use 2 washers per mounting screw.
Benching pins may be used to locate the sensor if the system mechanical tolerances are adequate. See data sheet for alignment tolerances, or keep mounting screws loose for sensor alignment if benching pins are not used.

Installation Instructions

Rotary Encoders - Using Sin/Cos Signals - Alignment

4

MAIN TRACK ALIGNMENT

If benching dimensions cannot be provided, proper sensor alignment may require minor adjustments to the sensor position with respect to the scale. This can be performed by maximizing the sine signal from the M1500S.

Using an oscilloscope, monitor the sine or cosine signal (refer to the interface drawing for pinouts) while moving the sensor over the scale. Align the sensor until 0.8 volts peak-to-peak +/- 25% is obtained. When alignment is completed, tighten the sensor mounting screws (0.37Nm [3.3 inch-lbs.] maximum torque).

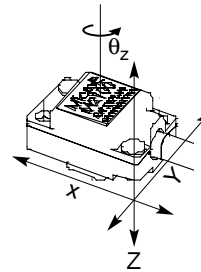

To align the sensor, move it in the Y or θ_z directions.

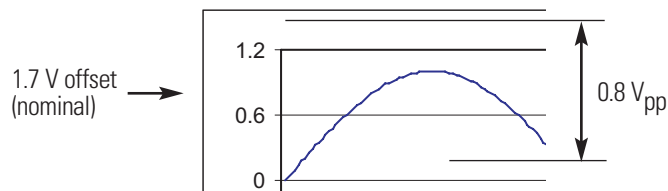

5

INDEX TRACK ALIGNMENT

The M1500S must be aligned for both the main and index tracks. When properly aligned, the sensor will produce an index window as the sensor passes over the index mark. The index window is approximately one fringe wide (20 μ m). To verify proper index track alignment, use a digital oscilloscope triggered on the index window. Refer to the interface drawing for the index window pinout.

Confirm proper alignment of the main track over the full range of motion. If not aligned over the entire range of motion, loosen the sensor mounting screws and repeat steps 4 and 5.

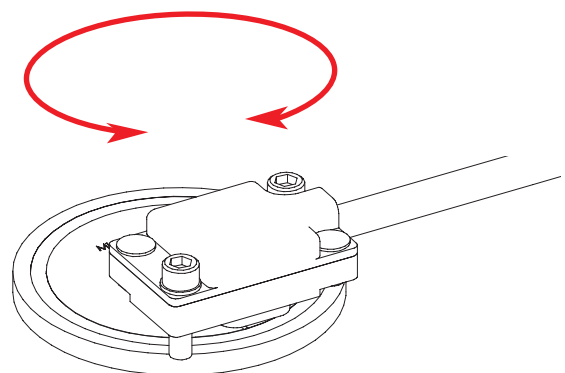

Installation Reference Guide

Positioning the Scale

Note: Before beginning mounting procedure, use talc-free gloves or finger cots to handle the scales.

"Benching" the scale to the system means aligning the scale by means of benching pins. Pin locations are described on the appropriate interface drawing.

Two benching pins are recommended on the long side of the scale and one at the end as shown. This is marked datum A on the interface drawing.

1 Position the benching pins in from either end. 20% of the overall scale length is the recommended location from the edge.

2 Be sure the benching pins do not extend too high in the Z direction to prevent mechanical interference with the sensor or sensor mount.

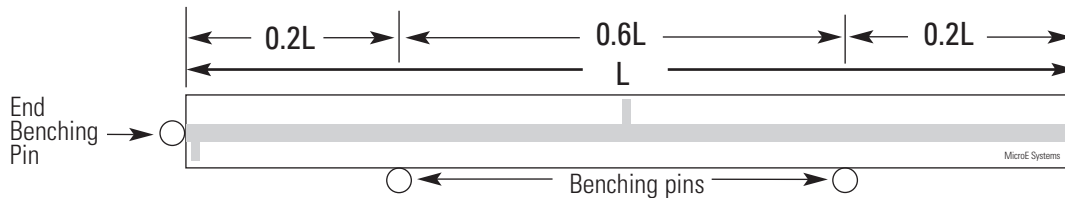

Mounting the Scale

MicroE Systems' linear scales should be affixed to the mounting surface. Two different approaches are described below:

Epoxy and RTV Mounting (Recommended for best accuracy)

1 Make sure the mounting surface is clean and dry.

3 Optional scale clamps may be used to secure the scale while the adhesive cures. Avoid damage to the top surface.

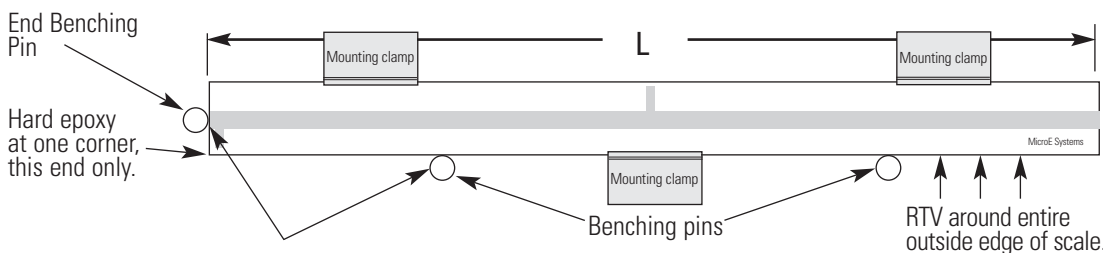

2 Align the scale by placing the edges against the benching pins.

Scale clamp with adhesive



Side view showing optional scale clamps and scale. Space clamps every 75mm on scales over 150 mm in length.

4 Apply a hard epoxy, such as Tra-Con's Tra-Bond 2116, to the end of the scale at the end benching pin. Apply 100% Silicone RTV adhesive around the edges of the scale. This method allows thermal expansion from the benched end of the scale. After adhesive curing, remove the scale mounting clamps or, if permanently installing clamps, make sure they do not interfere with the sensor or sensor mount.

Two Sided Adhesive Tape Mounting

1 Make sure the mounting surface is clean and dry. Peel the cover paper off and place the scale above the final location.

3 Gently place the scale on the mounting surface. Positioning adjustments can be made until the scale is firmly pressed down. After final positioning, push down on the top of the scale to secure it.

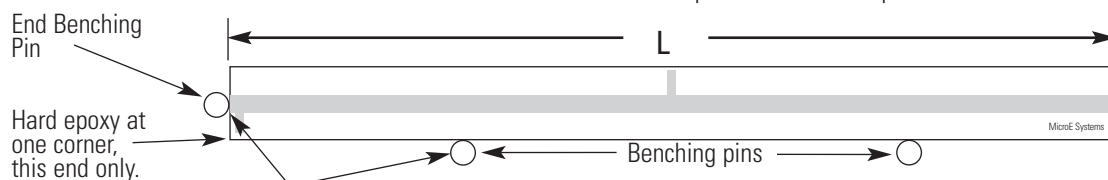

2 Align the scale by placing the edges against the benching pins.

Grounding of M1500S

Grounding Instructions for Mercury 1500S Encoder System

For Mercury 1500S encoder systems to operate reliably, it is essential that the sensor and cable shield are grounded properly according to the following instructions. The diagrams below show how to make the connections when the encoder's connector is plugged into the customer's controller chassis. If a customer-supplied extension cable is used, it should be a double shielded cable with conductive connector shells and must provide complete shielding over the conductors contained within it over its entire length. Furthermore, the shields should be grounded at the connection to the controller chassis the same way as the encoder connectors in the diagrams below.

Note: For best performance, isolate the encoder outer shield from motor cable shields and separate the encoder cable as far as possible from motor cables.

Sensor mounted with good electrical contact to a well-grounded surface (preferred)

- 15-pin D-sub connector grounding: The encoder's connector shell must be in intimate, electrically conductive contact with the customer-supplied mating connector, which must be isolated from the controller's ground. If a customer-supplied shielded cable connects the encoder to the controller, then the outer shield on the customer-supplied cable must be isolated from the controller's ground.
- The sensor mounting surface must have a low impedance (DC/AC) connection to ground. The encoder sensor mounting surface may have to be masked during painting or anodizing to insure good electrical contact with the sensor.

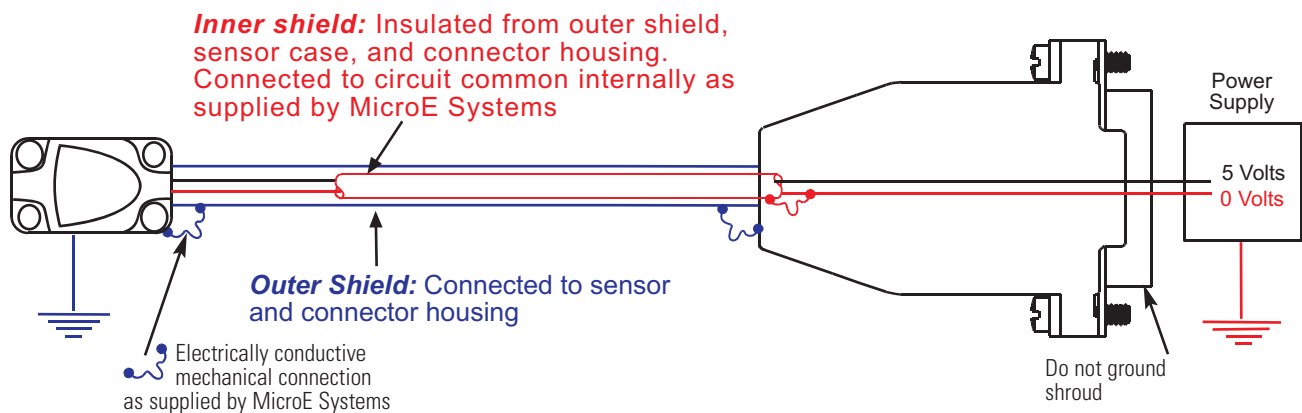

Sensor mounted to a surface that is grounded through bearings or a poorly-grounded surface, or mounted to a non-conducting surface

- 15-pin D-sub connector grounding: The encoder's connector shell must be in intimate, electrically conductive contact with the customer-supplied mating connector, which must be connected to the controller's ground. If a customer-supplied shielded cable connects the encoder to the controller, then the outer shield on the customer-supplied cable must be connected to the controller's ground. The controller must be grounded to earth at the point of installation.
- The encoder sensor must be mounted so that it is electrically isolated from ground.

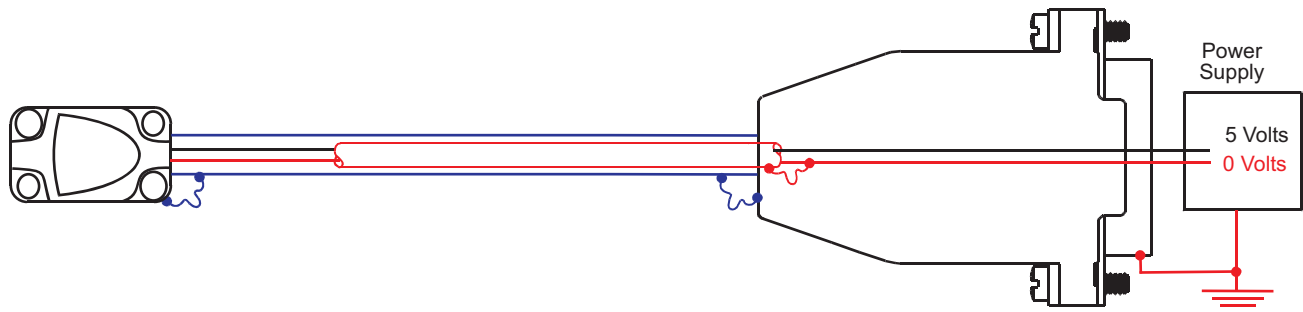

Recommendations for Power

Mercury encoders require a minimum of 4.75V DC continuously. When designing circuits and extension cables to use Mercury encoders, be sure to account for voltage loss over distance and tolerances from the nominal supply voltage so that at least 4.75V DC is available to the Mercury encoder under all operating conditions. Do not exceed 5.25V DC.

Customer Interface Cable Requirements

Customer cables that interface to Mercury series encoders must have the following characteristics:

- Twisted pair signal wiring.
- Characteristic impedance of 100-120 ohms.
- Sufficient wire gauge to meet the minimum voltage requirement at the encoder, for example 24AWG gauge wire for a 2m length cable. Examples of acceptable cables with 24 AWG gauge wire and 4 twisted pairs are Belden 9831, 8104, and 9844 or other manufacturer's equivalents.
- Single shield cable with a minimum of 90% coverage. Note that a double shielded cable may be required in high-noise applications.

Signal Wiring:

Each differential signal should be connected to a corresponding twisted pair as follows:

Mercury 1500S	
Signal	Twisted Pair
A+	Pair 1
A-	
B+	Pair 2
B-	
Index+	Pair 3
Index-	
+5V	Pair 4
GND	

Shield Termination:

The customer's cable shield should be in 360° contact with the connector shroud and the connector shell to provide complete shielding. The connector shell should be metal with conductive surfaces. Suggested metal connector shells for use with Mercury 3500, 3000, 3000Si, and 2000 encoders: AMP 748676-1 or equivalent; for Mercury 1000 and 1500S encoders: AMP 745172-3, -2, or -1 where the dash number is dependent on the customer's outside cable diameter. The shield should be terminated as illustrated in the following diagram.

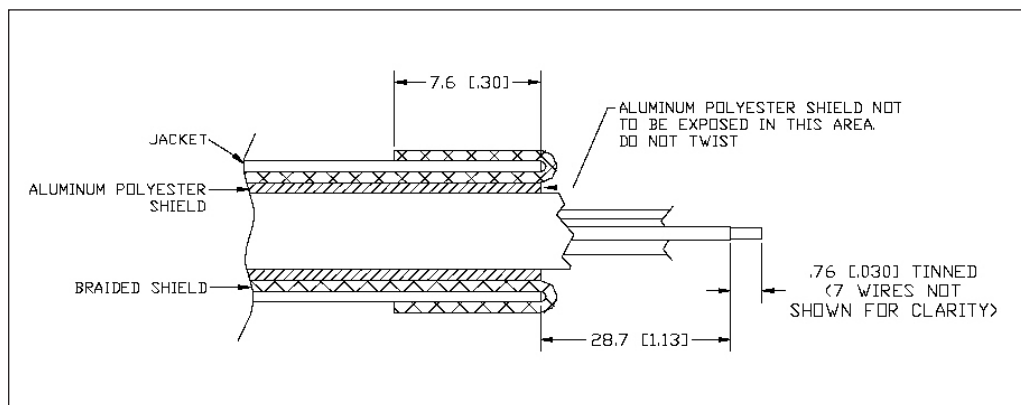

Fold braided shield back over jacket. Example shows double-shielded cable. Dimensions shown are for illustration only.

Output Signal Description

SINE+/COSINE+

Analog signal with nominal peak to peak amplitude of 0.8V. The output signal has a source impedance of 1K Ω . This signal is only used to align the sensor using an oscilloscope and is not suitable for feedback in a control system.

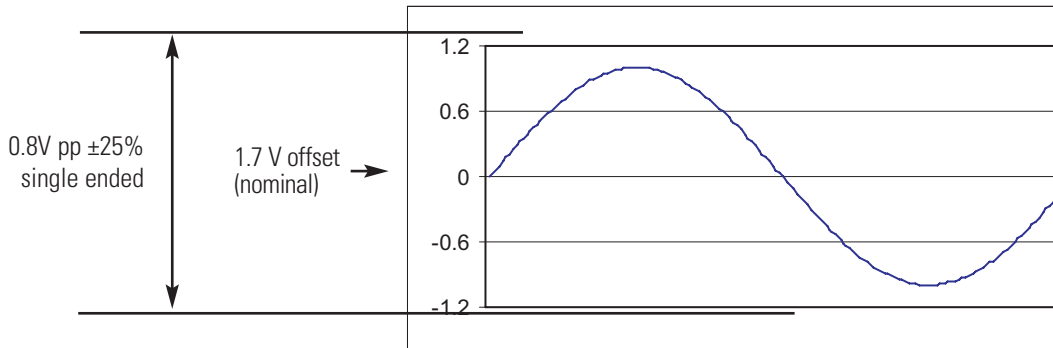

Output Signal Description

A+/A- Digital Quadrature output. Signal is a RS-422 compatible square wave. Pulses are 90° out of phase with B+/B- outputs. Please see below.

B+/B- Digital Quadrature output. Signal is a RS-422 compatible square wave. Pulses are 90° out of phase with A+/A- outputs. Please see below.

Index Window

The Index Window defines one particular fringe on the grating.

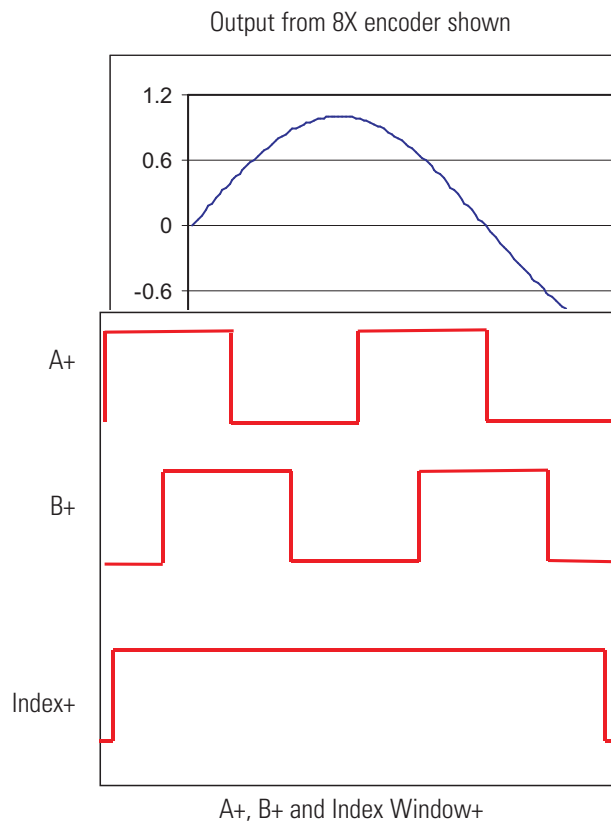

Troubleshooting

Problem

The Power/Calibration indicator will not come on.

Solution

- Make sure the M1500S 15-pin D connector is fully seated and connected.
- Confirm that +5 Volts DC is being applied to pin 12 on the M1500S 15-pin D connector and that pin 13 is connected to ground.

Problem

Can't get the SmartPrecision Alignment Tool "Signal" LEDs better than red or yellow; or the green, "green" indicator doesn't stay illuminated over the full length of the scale.

Solution

- Verify that the sensor has been aligned to the scale and that the mounting screws are tight. Check the dimensions for the mechanical mounting holes (and clamps if any) to make sure that the sensor is correctly located over the scale. Refer to the appropriate interface drawing.
- Check that the scale is firmly mounted and can't jiggle or move in other than the intended direction.
- Make sure that the scale is clean over its entire length or circumference. Use the recommended Cleaning Scales procedure.

Cleaning Scales



General Particle Removal

Blow off the contamination with nitrogen, clean air, or a similar gas.

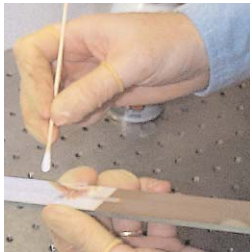

Contamination Removal

Use a lint-free cleanroom wipe or cotton swab dampened with isopropyl alcohol or acetone only to wipe the surface clean. Handle the scale by the edges. Do not scrub the scale.

Contact MicroE Systems

Thank you for purchasing a MicroE Systems product. You should expect the highest level of quality and support from MicroE. If you want to download the Mercury Encoder Installation Manual, Data Sheet or Interface Drawing, browse www.microesys.com and click on the Mercury Encoders button.

