

---

# Whistle Evaluation Board User Guide

(Also available for Hornet and Tweeter)

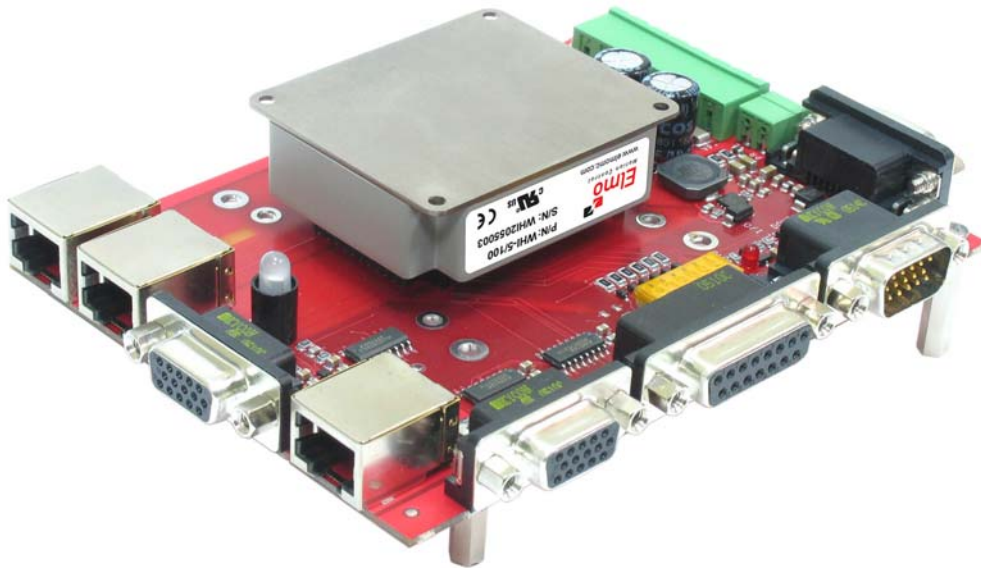

September 2008 (Ver. 1.1)

---

## Notice

This guide is delivered subject to the following conditions and restrictions:

- This guide contains proprietary information belonging to Elmo Motion Control Ltd. Such information is supplied solely for the purpose of assisting users of the Whistle servo drive in its evaluation and testing.
- The text and graphics included in this manual are for the purpose of illustration and reference only. The specifications on which they are based are subject to change without notice.
- Elmo Motion Control and the Elmo Motion Control logo are trademarks of Elmo Motion Control Ltd.
- Information in this document is subject to change without notice.

Document No. MAN-EVLBRD-WHI  
Copyright ©2008  
Elmo Motion Control Ltd.  
All rights reserved.

<b>Evaluation Board Catalog Number</b>	WHI-EVLBRD-1
--	--------------

### Related Products:

<b>Whistle Catalog Numbers</b> <b>Whistle Installation Guide Cat. No.</b>	WHI-XXX-YYYY MAN-WHISIG (available on our web site)
--	--

### Revision History:

Version	Release Date	Status	Changes/Remarks
Ver 1.1*	September 2008		Now available for Hornet and Tweeter
Ver 1.1	September 2005		Some revisions to cable information
Ver 1.0	September 2005	First release	(MAN- EVLBRD-WHI.PDF)

<b>Elmo Motion Control Ltd.</b> 64 Gissin St., P.O. Box 463 Petach Tikva 49103 Israel Tel: +972 (3) 929-2300 Fax: +972 (3) 929-2322 <a href="mailto:info-il@elmomc.com">info-il@elmomc.com</a>	<b>Elmo Motion Control Inc.</b> 1 Park Drive, Suite 12 Westford, MA 01886 USA Tel: +1 (978) 399-0034 Fax: +1 (978) 399-0035 <a href="mailto:info-us@elmomc.com">info-us@elmomc.com</a>	<b>Elmo Motion Control GmbH</b> Steinkirchring 1 D-78056, Villingen-Schwenningen Germany Tel: +49 (0) 7720-85 77 60 Fax: +49 (0) 7720-85 77 70 <a href="mailto:info-de@elmomc.com">info-de@elmomc.com</a>	 <b>Elmo</b> Motion Control <a href="http://www.elmomc.com">www.elmomc.com</a>
--	--	---	--

# Contents

<b>Chapter 1: Safety Information .....</b>	<b>1-1</b>
1.1 Warnings .....	1-2
1.2 Cautions .....	1-2
1.3 Directives and Standards .....	1-3
1.4 CE Mark Conformance.....	1-3
1.5 Warranty Information.....	1-3
1.6 Before You Begin.....	1-4
1.6.1 Site Requirements .....	1-4
<b>Chapter 2: Evaluation Board Connectors and Cable .....</b>	<b>2-1</b>
2.1 Connector Types on Evaluation Board .....	2-1
2.2 Evaluation Board-Connector Cross-Reference Table .....	2-2
2.3 Whistle Evaluation Board Block Diagram.....	2-3
2.4 Whistle Connections on Evaluation Board .....	2-4
2.4.1 Connector J1 .....	2-5
2.4.2 Connector J2 .....	2-6
2.4.3 Connecting the Whistle to the Evaluation Board.....	2-6
2.5 The Main Power and Motor Power Connector.....	2-7
2.5.1 Connecting Motor Power .....	2-7
2.5.2 Connecting Main Power .....	2-8
2.6 The Auxiliary Supply Connector .....	2-8
2.7 Auxiliary Supply (optional).....	2-9
2.8 The External Power Connector.....	2-10
2.9 Main Feedback .....	2-11
2.10 Main Buffered Output Port.....	2-16
2.11 Auxiliary Feedback (bi-directional).....	2-18
2.11.1 Main and Auxiliary Feedback Combinations .....	2-19
2.11.2 Auxiliary Feedback – Emulated, Differentially Buffered Encoder Output Option (YA[4]=4) .....	2-20
2.11.3 AUX. FEEDBACK - Single-ended Encoder Input Option (YA[4]=2) .....	2-22
2.11.4 AUX FEEDBACK – Single-Ended Pulse-and-Direction Input Option (YA[4]=0) .....	2-24
2.12 General I/O Port .....	2-26
2.12.1 Digital Input & DIP Switch Settings.....	2-27
2.12.2 Digital Output .....	2-27
2.12.3 Analog Input .....	2-28
2.13 Communications.....	2-28
2.13.1 RS-232 Communication.....	2-29
2.13.2 CANopen Communication.....	2-30
2.14 Powering Up.....	2-32
2.15 Initializing the System.....	2-32

**Appendix: Cables .....A-1**

- A.1 Cable Photos.....A-1
- A.2 Cable Kits.....A-2
- A.3 Main Feedback Cable (CBL-DFDBK) .....A-3
- A.4 Auxiliary Feedback and Main Buffered Output Cable (CBL-CELAUX-1) .....A-4
- A.5 General I/O (CBL-CELIO1-1).....A-5
- A.6 Motor Power Cables (CBL-MTRPWR3-1).....A-6
- A.7 Auxiliary Power Cable (CBL-CEL24-1) .....A-6
- A.8 Communication Cables.....A-7
  - A.8.1 RS-232 Option (CBL-RJ452321-1)..... A-7
  - A.8.2 CAN Option (CBL-RJ45CAN1-1) ..... A-8
- A.9 Guidelines for Making Your Own Cables.....A-9
  - A.9.1 Recommended Wire Cross Sections ..... A-10
  - A.9.2 Feedback and Control Cable Assemblies..... A-10

# Chapter 1: Safety Information

In order to achieve the optimum, safe operation of the Whistle Evaluation Board, it is imperative that you implement the safety procedures included in this installation guide. This information is provided to protect you and to keep your work area safe when operating the Whistle Evaluation Board and accompanying equipment.

**Please read this chapter carefully before you begin the installation process.**



Before you start, ensure that all system components are connected to earth ground. Electrical safety is provided through a low-resistance earth connection.

Only qualified personnel may install, adjust, maintain and repair the servo drive. A “qualified person” has the knowledge and authorization to perform tasks such as transporting, assembling, installing, commissioning and operating motors.





The Whistle Evaluation Board contains electrostatic-sensitive components that can be damaged if handled incorrectly. To prevent any electrostatic damage, avoid contact with highly insulating materials, such as plastic film and synthetic fabrics. Place the product on a conductive surface and ground yourself in order to discharge any possible static electricity build-up.

To avoid any potential hazards that may cause severe personal injury or damage to the product during operation, keep all covers and cabinet doors shut.





The following safety symbols are used in this manual:

	<b>Warning:</b> This information is needed to avoid a safety hazard, which might cause bodily injury.
	<b>Caution:</b> This information is necessary for preventing damage to the product or to other equipment.
	<b>Note:</b> This is auxiliary information that ensures the correct operation of the equipment.

## 1.1 Warnings

	To avoid electric arcing and hazards to personnel and electrical contacts, never connect/disconnect the servo drive while the power source is on.
	Power cables can carry a high voltage, even when the motor is not in motion. Disconnect the Whistle Evaluation Board from all voltage sources before it is opened for servicing.
	The Whistle Evaluation Board contains grounding conduits for electric current protection. Any disruption to these conduits may cause the instrument to become hot (live) and dangerous.
	After shutting off the power and removing the power source from your equipment, wait at least 1 minute before touching or disconnecting parts of the equipment that are normally loaded with electrical charges (such as capacitors or contacts). Measuring the electrical contact points with a meter, before touching the equipment, is recommended.

## 1.2 Cautions

	The Whistle Evaluation Board contains hot surfaces and electrically-charged components during operation.
	The maximum DC power supply connected to the instrument must comply with the parameters outlined in this guide. Furthermore, the power supply must be isolated from hazardous live voltages using reinforced or double insulation in accordance to approved safety standards.
	When connecting the Whistle Evaluation Board to an approved 12 ~ 95V DC auxiliary power supply, connect it through a line that is isolated from hazardous live voltages using reinforced or double insulation in accordance with approved safety standards.
	Before switching on the Whistle Evaluation Board, verify that all safety precautions have been observed and that the installation procedures in this manual have been followed.

### 1.3 Directives and Standards

The Whistle Evaluation Board conforms to the following industry safety standards:

Safety Standard	Item
In compliance with <b>UL508c</b>	Power Conversion Equipment
In compliance with <b>UL840</b>	Insulation Coordination, Including Clearance and Creepage Distances of Electrical Equipment
In compliance with <b>UL60950-1</b> (formerly UL1950)	Safety of Information Technology Equipment, Including Electrical Business Equipment
In compliance with <b>EN60204-1</b>	Low Voltage Directive, 73/23/EEC

The Whistle Evaluation Board has been developed, produced, tested and documented in accordance with the relevant standards. Elmo Motion Control is not responsible for any deviation from the configuration and installation described in this documentation. Furthermore, Elmo is not responsible for the performance of new measurements or ensuring that regulatory requirements are met.

### 1.4 CE Mark Conformance

The Whistle Evaluation Board is intended for incorporation in a machine or end product. The actual end product must comply with all safety aspects of the relevant requirements of the European Safety of Machinery Directive 98/37/EC as amended, and with those of the most recent versions of standards EN60204-1 and EN292-2 at the least.

According to Annex III of Article 13 of Council Directive 93/68/EEC, amending Council Directive 73/23/EEC concerning electrical equipment designed for use within certain voltage limits, the Whistle Evaluation Board meets the provisions outlined in Council Directive 73/23/EEC. The party responsible for ensuring that the equipment meet the limits required by EMC regulations is the manufacturer of the end product.

### 1.5 Warranty Information

The products covered in this manual are warranted to be free of defects in material and workmanship and conform to the specifications stated either within this document or in the product catalog description. All Elmo drives are warranted for a period of 12 months from the time of installation, or 18 months from time of shipment, whichever comes first. No other warranties, expressed or implied – and including a warranty of merchantability and fitness for a particular purpose – extend beyond this warranty.

## 1.6 Before You Begin

### 1.6.1 Site Requirements

You can guarantee the safe operation of the Whistle Evaluation Board by ensuring that it operates in an appropriate environment.

Feature	Value
Ambient operating temperature	0° to 40°C (32° to 104°F)
Maximum relative humidity	90% non-condensing
Operating area atmosphere	No flammable gases or vapors permitted in area



The Whistle on the Whistle Evaluation Board dissipates its heat by convection. The maximum operating ambient temperature of 0 to 40° C (32 to 104° F) must not be exceeded. Refer to the Heat Dissipation section of the *Whistle Installation Guide* for more information.





# Chapter 2: Evaluation Board Connectors and Cable

The Whistle Evaluation Board was designed to help when evaluating the Whistle Digital Servo Drive. It comes with standard terminal blocks for power connections and D-sub plugs/sockets for signals connections. It also comes with a complete set of cables for connecting to the board.

## 2.1 Connector Types on Evaluation Board

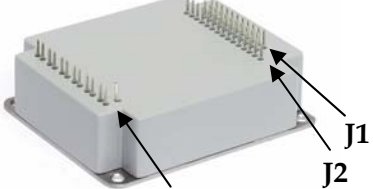
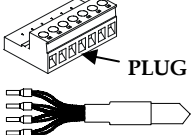
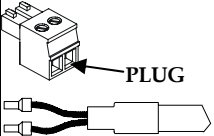
Type	Connector	Connector Location
Whistle "J1"	22-pin 2mm pitch double-row socket	
Whistle "J2"	15-pin 2mm pitch single row socket	
Whistle Power	6 pairs of 2mm pitch sockets in a row & a single 2-pin socket	
Main Power and Motor Power	7-pin Phoenix Terminal Block Socket	
Auxiliary Power	2-pin Phoenix Terminal Block Socket	
External Power	9-pin D-Sub Socket	
General I/O	15-pin hi-density D-Sub Plug	
Main Feedback	15-pin D-Sub Socket	
Main Buffered Output	15-pin hi-density D-Sub Socket	
RS-232	8-pin RJ-45 socket	
Auxiliary Feedback	15-pin hi-density D-Sub Socket	
CANopen Communication	2x 8-pin RJ-45 socket	

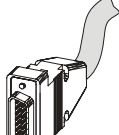
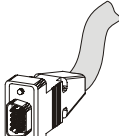
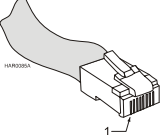
## 2.2 Evaluation Board-Connector Cross-Reference Table

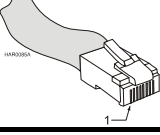
Catalog. No.	On-Board Sockets	Whistle Pin Sets	Whistle Photo	
SAMTEC SQT-111-01-L-D	22-pin 2mm pitch double-row socket	Whistle "J1"	 <p>Main Power and Motor Power</p>	
SAMTEC SQT-115-01-L-S	15-pin 2mm pitch single row socket	Whistle "J2"		
SAMTEC SQT-102-01-L-S	6 pairs of 2mm pitch sockets in a row & a single 2-pin socket	Whistle Power		
Type	On-Board Connector	Complementary Cable Name	Catalog. No.	Cable Drawing
Main Power and Motor Power	5 mm pitch 7-pin Header + 7-pin Plug	Motor Power Cable	Pheonix 1759062 CBL-MTRPWR3-1	
Auxiliary Power	3.81 mm pitch 2-pin Header + 2-pin Plug	Auxiliary Power Cable	Pheonix 1803277 CBL-CEL24-1	
General I/O	15-pin hi-density D-Sub Plug	General I/O Cable	CBL-CELI01-1	
Main Feedback	15-pin D-Sub Socket	General Purpose Main Feedback Cable	CBL-DFDBK-1	
Main Buffered Output	15-pin hi-density D-Sub Socket	Main Feedback Buffered Output Cable	CBL-CELIO2-1	
RS-232	8-pin RJ-45 socket	RS-232 Cable	CBL-RJ45RS2321-1	
Auxiliary Feedback	15-pin hi-density D-Sub Socket	Auxiliary Feedback Cable	CBL-CELAUX-1	
CANopen Communication	2x 8-pin RJ-45 socket	CAN Cable	CBL-RJ45CAN1-1	

## 2.3 Whistle Evaluation Board Block Diagram

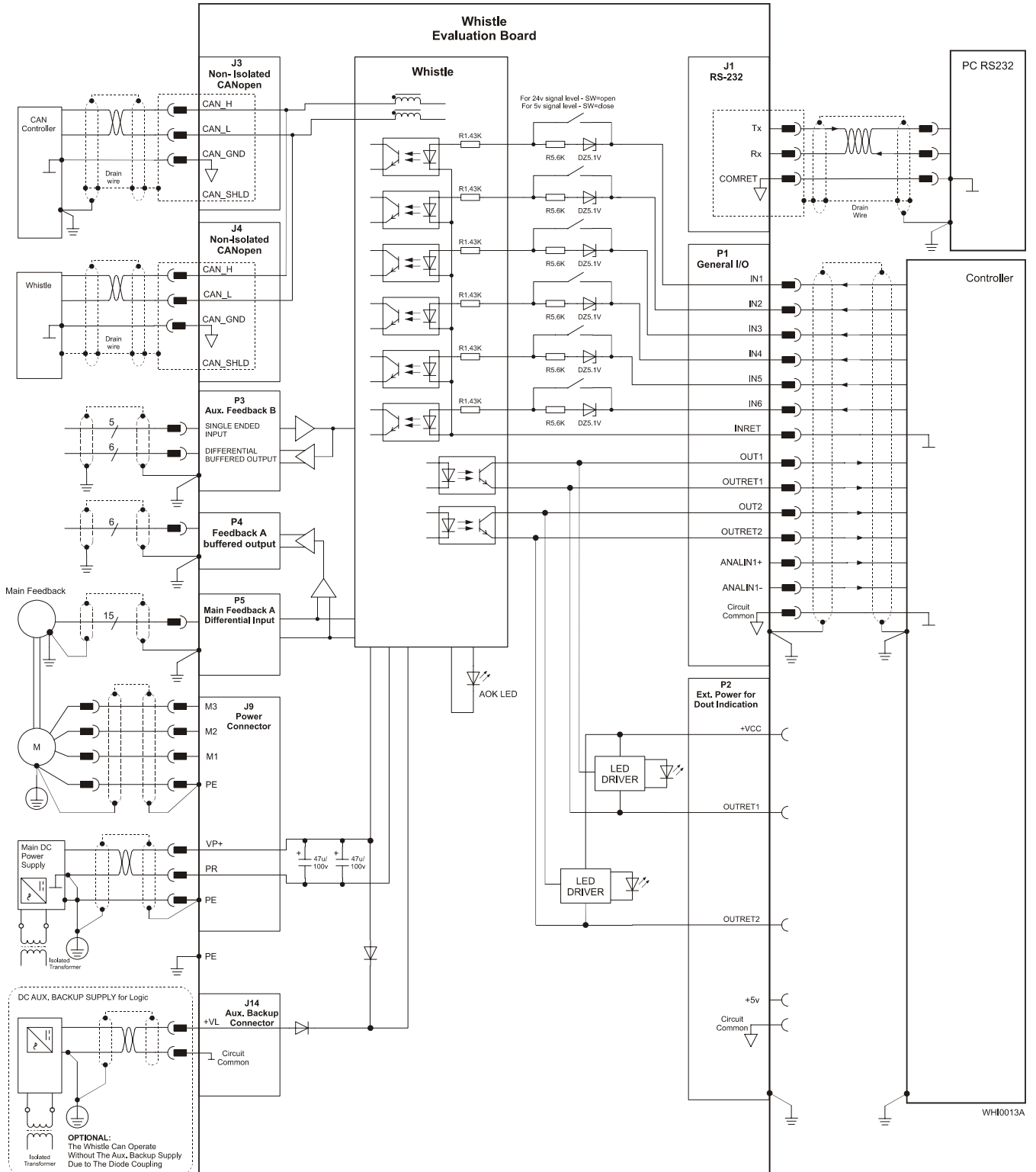

Figure 2-1: Whistle Evaluation Board Block Diagram

## 2.4 Whistle Connections on Evaluation Board

The Whistle is connected to the Evaluation Board by 2mm pitch header connectors. Upon assembly, the Whistle's J1, J2 and Power pins should be pressed directly into their respective sockets. Great care should be taken with alignment to avoid bending the pins.

No. Pins	Type	Port	Function	Connector Location
2x11	2 mm Pitch 0.51 mm SQ	J1	I/O, COMM, Auxiliary Feedback	
15	2 mm Pitch 0.51 mm SQ	J2	Main Feedback, Analog Input, LED	
2	2 mm Pitch 0.51 mm SQ	M1	Motor power output 1	
2		M2	Motor power output 2	
2		M3	Motor power output 3	
2		PE	Protective earth	
2		PR	Power input return	
2		VP+	Positive power input	
1		VL	Auxiliary power input	

### 2.4.1 Connector J1

Pin	Signal	Function
J1/1	RS232_RX	RS232 receive
J1/2	RS232_TX	RS232 Transmit
J1/3	RS232_COMRET	Communication return
J1/4	SUPRET	Supply return
J1/5	AUX PORT CHA	Auxiliary Port Channel A (bi-directional)
J1/6	SUPRET	Supply return
J1/7	OUT1	Programmable Digital output 1
J1/8	OUT2	Programmable Digital output 2
J1/9	IN1	Programmable Digital input 1
J1/10	IN2	Programmable Digital input 2
J1/11	IN3	Programmable Digital input 3
J1/12	IN4	Programmable Digital input 4
J1/13	IN5	Programmable Digital input 5
J1/14	IN6	Programmable Digital input 6
J1/15	INRET	Programmable Digital input return
J1/16	OUTRET2	Programmable Digital output return 2
J1/17	OUTRET1	Programmable Digital output return 1
J1/18	AUX PORT CHB	Auxiliary Port Channel B (bi-directional)
J1/19	AUX PORT INDEX	Auxiliary Port Channel Index (bi-directional)
J1/20	CAN_COMRET	Communication return
J1/21	CAN_L	CAN_L busline (dominant low)
J1/22	CAN_H	CAN_H busline (dominant high)

### 2.4.2 Connector J2

Pin	Signal	Function
J2/1	+5V	Encoder/Hall +5V supply voltage. Output current: 200mA.
J2/2	SUPRET	Supply return
J2/3	ANALIN1+	Analog input 1+
J2/4	ANALIN1-	Analog input 1-
J2/5	CHA	Channel A input
J2/6	CHA-	Channel A complement input
J2/7	CHB	Channel B input
J2/8	CHB-	Channel B complement input
J2/9	INDEX+	Index input
J2/10	INDEX-	Index complement input
J2/11	HA	Hall sensor A input
J2/12	HB	Hall sensor B input
J2/13	HC	Hall sensor C input
J2/14	LED_2_OUT	Indication output 2
J2/15	LED_1_OUT	Indication output 1

### 2.4.3 Connecting the Whistle to the Evaluation Board

Each Whistle has 50 pins, therefore, great care should be taken aligning its pins with the sockets on the board when assembling. Push the Whistle into the Evaluation Board firmly and evenly.

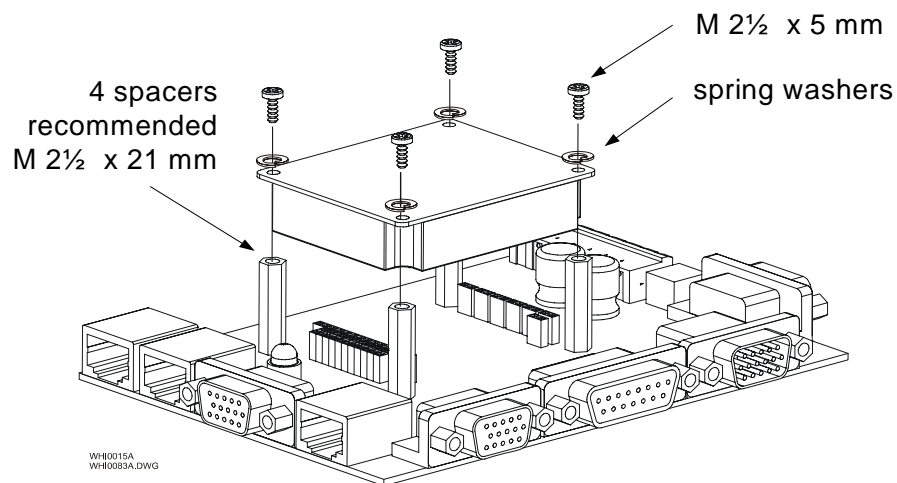

Figure 2-2: Assembling the Whistle on the Whistle Evaluation Board

## 2.5 The Main Power and Motor Power Connector

Pin	Function	Cable		Pin Positions
VP+	Pos. Power input	Power		
PR	Power return	Power		
PE	Protective earth	Power		
		AC Motor Cable	DC Motor Cable	
PE	Protective earth	Motor	Motor	
M1	Motor phase	Motor	N/C	
M2	Motor phase	Motor	Motor	
M3	Motor phase	Motor	Motor	
	When connecting several Whistles to several motors, all should be wired in an identical manner. This will enable the same SimplIQ program to run on all drives.			

Table 2-1: Connector for Main Power and Motor

### 2.5.1 Connecting Motor Power

Connect the motor power cable to the M1, M2, and M3 terminals of the main power connector and the fourth wire to the PE (Protective Earth). The phase connection order is arbitrary because the Composer will establish the proper commutation automatically during setup. If several motors/drive combinations are designed to operate in an identical manner, we recommend downloading the program into all the drives and connecting them in the same way.



#### Notes for connecting the motor cables:

- For best immunity, it is highly recommended to use a shielded (not twisted) cable for the motor connection. A 4-wire shielded cable should be used. The gauge is determined by the actual current consumption of the motor.
- Connect the shield of the cable to the closest ground connection at the motor end.

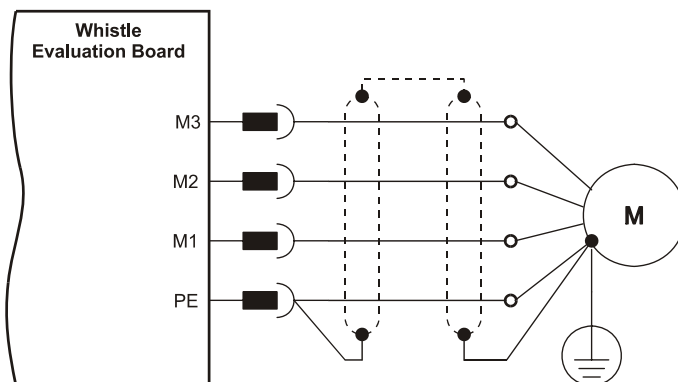

WHI0053A

Figure 2-3: AC Motor Power Connection Diagram

## 2.5.2 Connecting Main Power

Connect the main power supply cable to the VP+ and PR terminals of the main power connector.



### Notes for connecting the DC power supply:

- **The source of the 0 ~ 95 VDC Main Power Supply must be isolated.**
- For best immunity, it is highly recommended to use twisted and shielded cables for the DC power supply cable. A 3-wire shielded cable should be used. The gauge is determined by the actual current consumption of the motor.
- Connect the cable shield to the closest ground connection near the power supply.
- Connect the PE to the closest ground connection near the power supply.
- Connect the PR to the closest ground connection near the power supply.

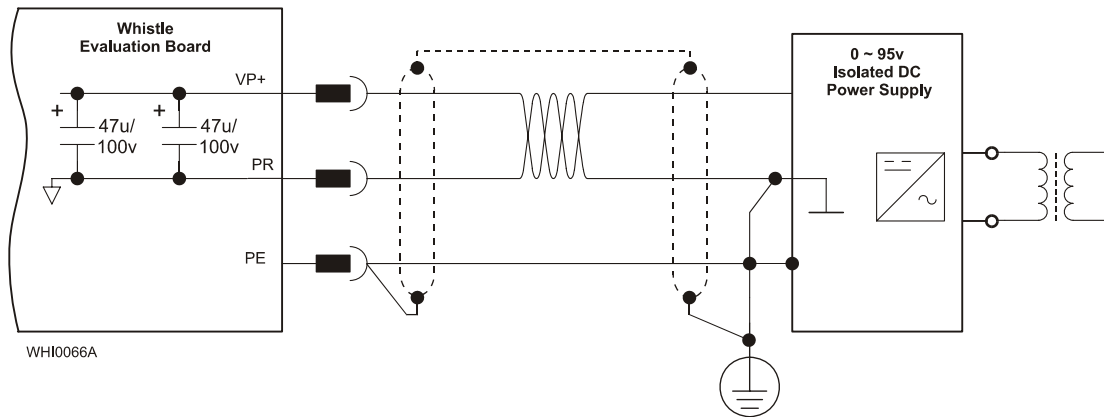

Figure 2-4: Main Power Supply Connection Diagram

## 2.6 The Auxiliary Supply Connector

Pin	Function	Pin Positions
VL	Auxiliary Supply Input	
PR	Power Input Return	

Table 2-2: Auxiliary Supply Connector

## 2.7 Auxiliary Supply (optional)



Notes for 12 ~ 95 VDC Auxiliary Supply connections:

- **The source of the 12 ~ 95 VDC Auxiliary Supply must be isolated from the main.**
- For safety reasons, connect the return (common) of the Auxiliary Supply source to the closest ground near the Auxiliary Supply source.
- Connect the cable shield to the closest ground near the Auxiliary Supply source.
- Before applying power, first verify the polarity of the connection.



**Caution:** Power to the Whistle must come from the Main Supply and NOT from the Auxiliary Supply.

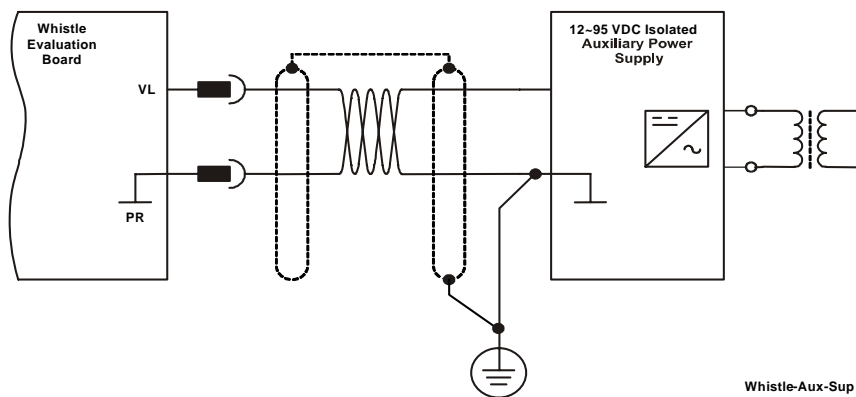

Figure 2-5: Auxiliary Supply Connection Diagram

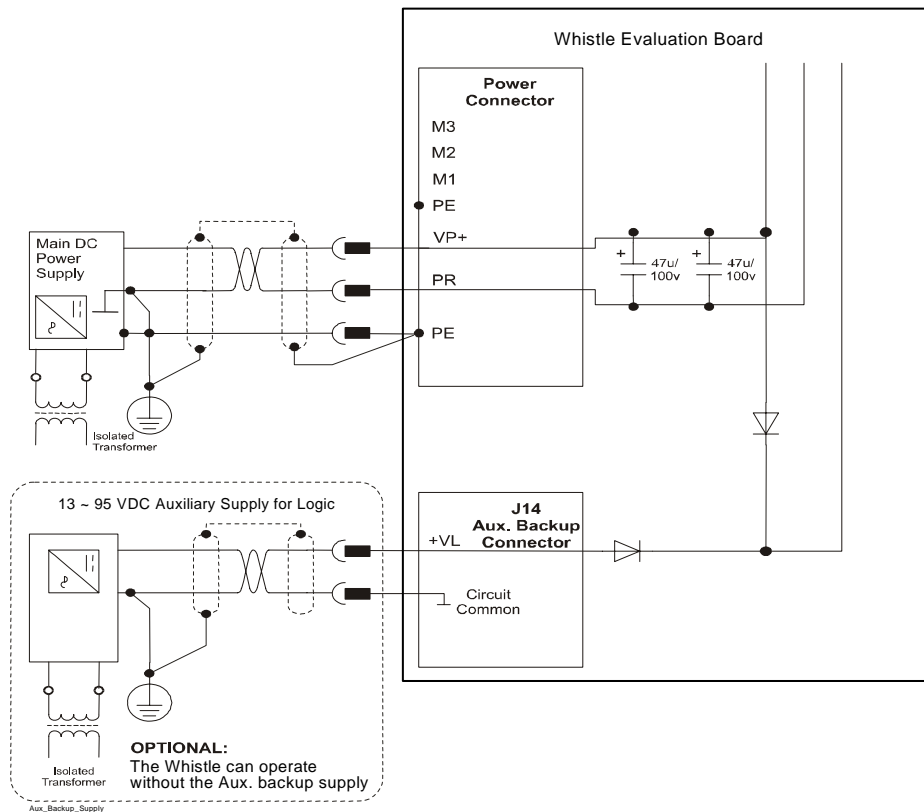

Figure 2-6: Shared Supply Connection Diagram

## 2.8 The External Power Connector

Pin	Signal	Function	Pin Positions
1	VCC	External +5v, for the LED drivers.	<p>9-Pole D-sub Power connector</p>
2	VCC	External +5v, for the LED drivers.	
3	+5V	Non-isolated +5V Supply	
4	+5V	Non-isolated +5V Supply	
5	SUPRET	Non-isolated +5V Supply Return	
6	OUTRET1	Programmable output 1 return	
7	OUTRET1	Programmable output 1 return	
8	OUTRET2	Programmable output 2 return	
9	OUTRET2	Programmable output 2 return	

Table 2-3: External Power Connector

By supplying +5V to the LED drivers through this connector, users can enable "on-board" digital output LED indication. Two modes of operation are possible:

1. Isolated Mode -

This mode keeps Digital Outputs isolated. For this mode to work, an Isolated external +5v power supply has to be connected by the user in the following manner:

- the positive terminal is connected to VCC (pin 1)
- the negative terminal is connected to OUTRET1 (pin 6) and OUTRET2 (pin 8).

2. Non-Isolated Mode -

This mode is used when the Digital Outputs do not have to be isolated. The user can use the board's internal +5V supply to power the LED drivers. For Dout1 and Dout2 indication short VCC (pin 1) and +5V (pin 3) and do one or both of the following:

- for Dout1 indication, short SUPRET (pin 5) and OUTRET1 (pin6)
- for Dout2 indication, short SUPRET (pin 5) and OUTRET2 (pin8)

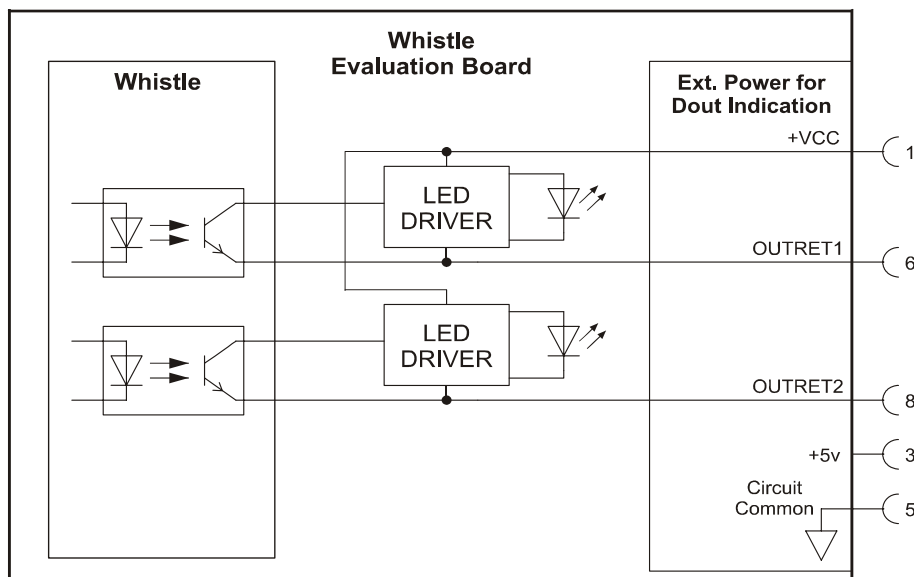

WHI0017A

Figure 2-7: External Power for Driving LEDs

## 2.9 Main Feedback

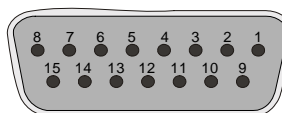

The Main Feedback port is used to transfer feedback data from the motor to the drive.

The Whistle Evaluation Board accepts the following as a main feedback mechanism:

- Incremental encoder only
- Incremental encoder with digital Hall sensors
- Digital Hall sensors only
- Incremental Analog (Sine/Cosine) encoder (option)
- Resolver (option)
- Tachometer and Potentiometer (option)

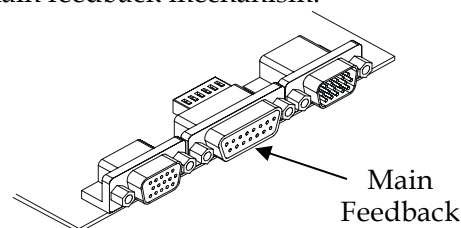

The Main Feedback port on the Whistle Evaluation Board has a 15-pin D-sub socket. Connect one end of the Main Feedback cable from the motor to the Main Feedback connector on the Evaluation Board.

Pin	Incremental Encoder		Interpolated Analog Encoder		Resolver		Tachometer and Potentiometer	
	Signal	Function	Signal	Function	Signal	Function	Signal	Function
	WHI XX/YYY_		WHI XX/YYYYI		WHI XX/YYYYR		WHI XX/YYYYT	
1	HC	Hall sensor C input	NC	-	NC	-	HC	Hall sensor C input
2	HA	Hall sensor A input	NC	-	NC	-	HA	Hall sensor A input
3	SUPRET	Supply return	SUPRET	Supply return	SUPRET	Supply return	SUPRET	Supply return
4	+5V	Encoder/Hall +5V supply	+5V	Encoder/Hall +5V supply	+5V	Encoder/Hall +5V supply	+5V	Encoder/Hall +5V supply
5	CHA-	Channel A complement	A-	Sine A complement	S3	Sine A complement	Tac 1-	Tacho Input 1 Neg. (20V max)
6	CHA	Channel A	A+	Sine A	S1	Sine A	Tac 1+	Tacho Input 1 Pos. (20V max)
7	INDEX-	Index complement	R-	Reference complement	R2	Vref complmnt f= 1/TS, 50mA Maximum	NC	-
8	INDEX	Index	R+	Reference	R1	Vref f=1/TS, 50mA Max.	POT	Potentiometer Input
9	SUPRET	Supply return	SUPRET	Supply return	SUPRET	Supply return	SUPRET	Supply return
10	HB	Hall sensor B input	NC	-	NC	-	HB	Hall sensor B input
11	SUPRET	Supply return	SUPRET	Supply return	SUPRET	Supply return	SUPRET	Supply return
12	+5V	Encoder/Hall +5V supply	+5V	Encoder/Hall +5V supply	+5V	Encoder/Hall +5V supply	+5V	Encoder/Hall +5V supply
13	SUPRET	Supply return	SUPRET	Supply return	SUPRET	Supply return	SUPRET	Supply return
14	CHB-	Channel B complement	B-	Cosine B complement	S4	Cosine B complement	Tac 2-	Tacho Input 2 Neg. (50V max)
15	CHB	Channel B	B+	Cosine B	S2	Cosine B	Tac 2+	Tacho Input 2 Pos. (50V max)

Table 2-4: Main Feedback Cable Pin Assignments

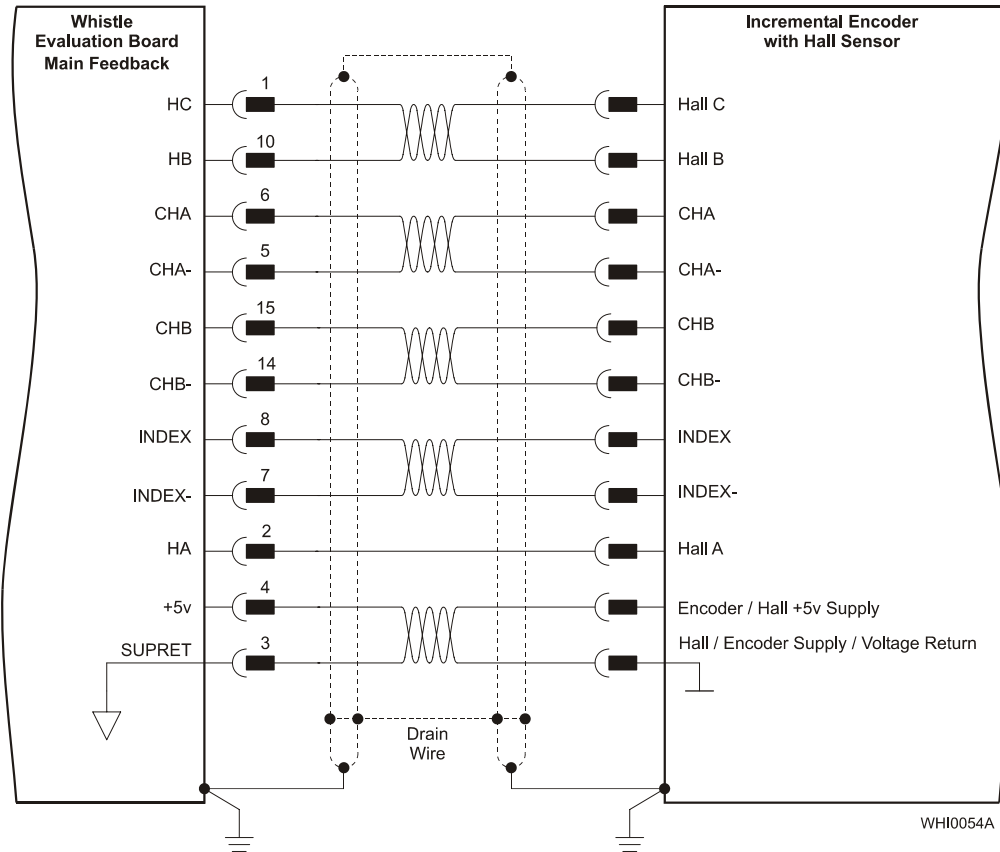

Figure 2-8: Main Feedback- Incremental Encoder Connection Diagram

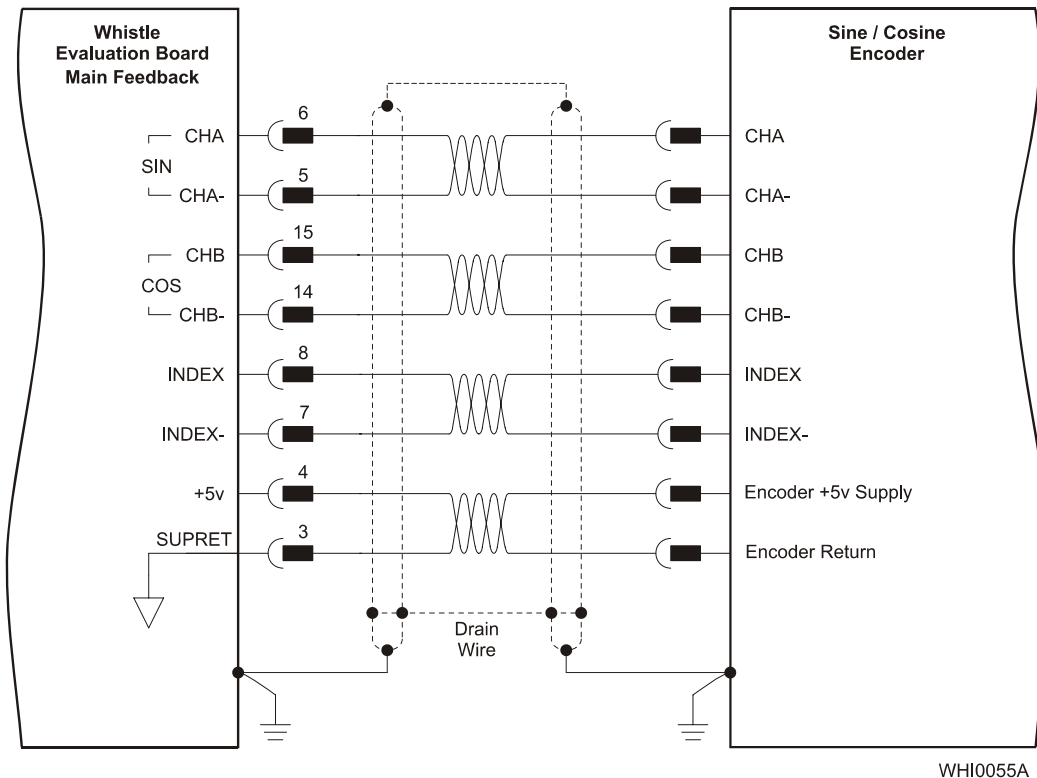
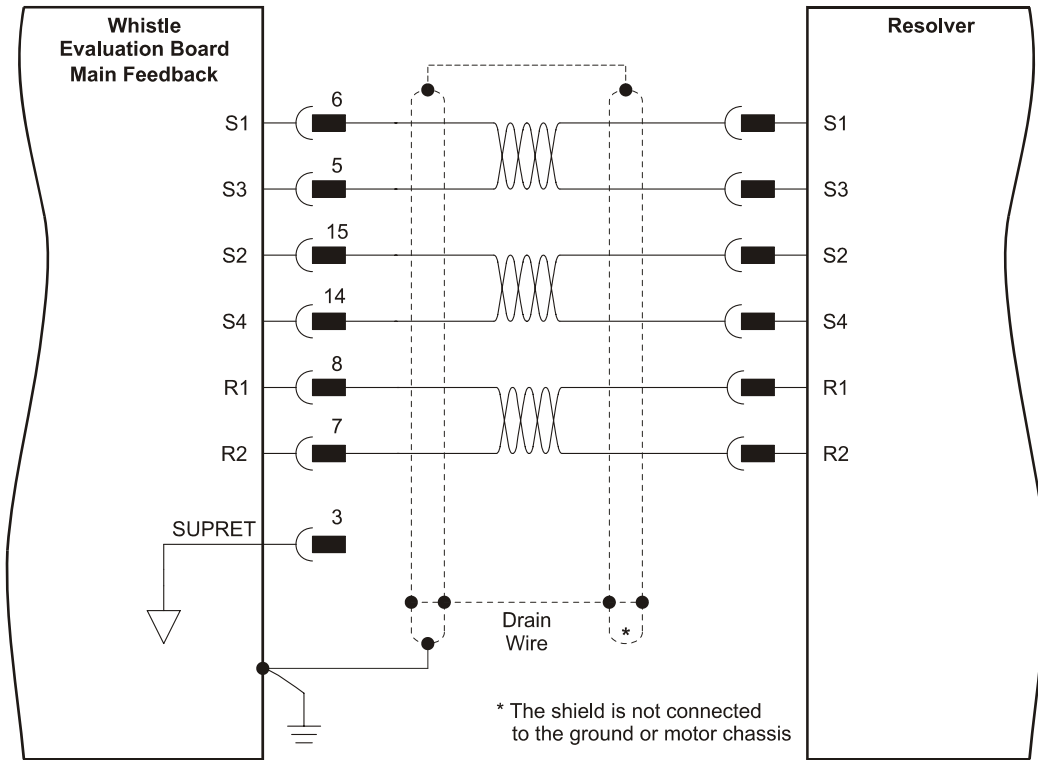
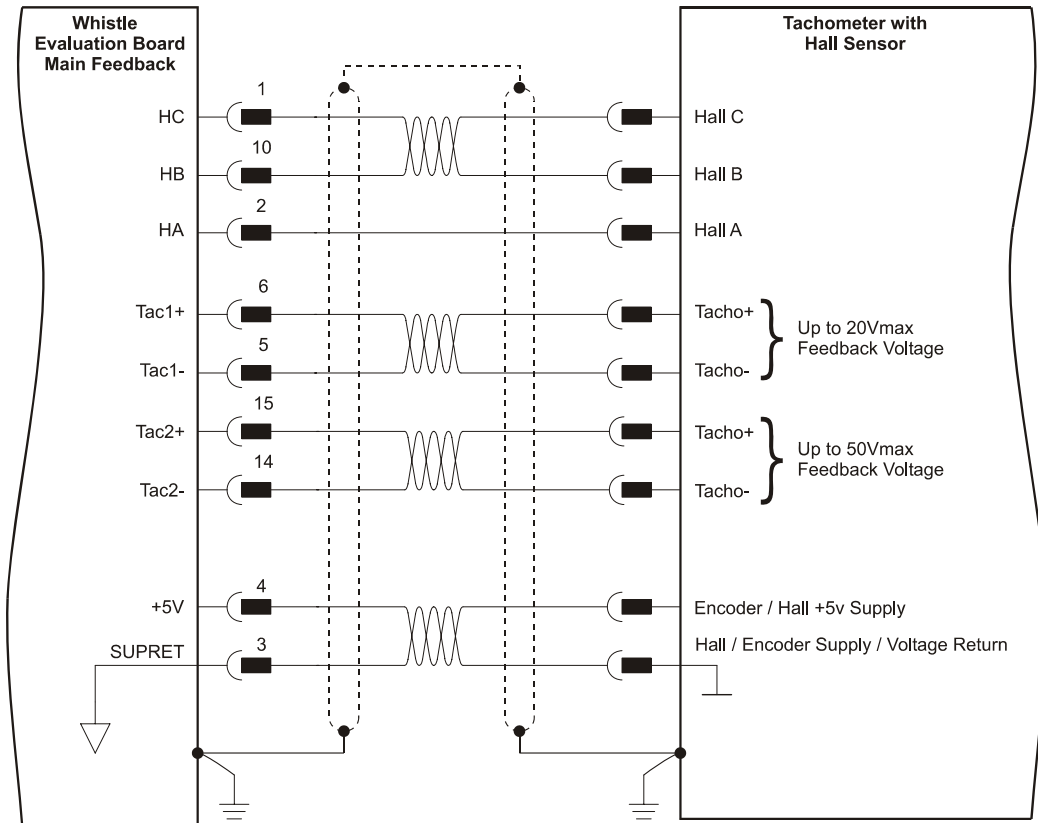

Figure 2-9: Main Feedback - Interpolated Analog Encoder Connection Diagram



WHI0056A

Figure 2-10: Main Feedback – Resolver Connection Diagram



WHI0057A

Only one tachometer port is available at a time

Figure 2-11: Main Feedback – Tachometer Feedback with Digital Hall Sensor Connection Diagram for Brushless Motors

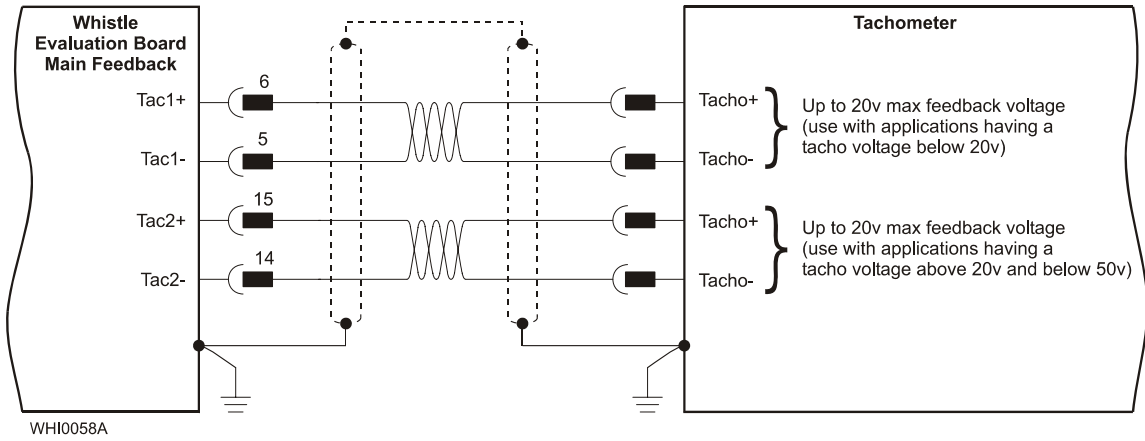

Only one tachometer port is available at a time

Figure 2-12: Main Feedback - Tachometer Feedback Connection Diagram for Brush Motors

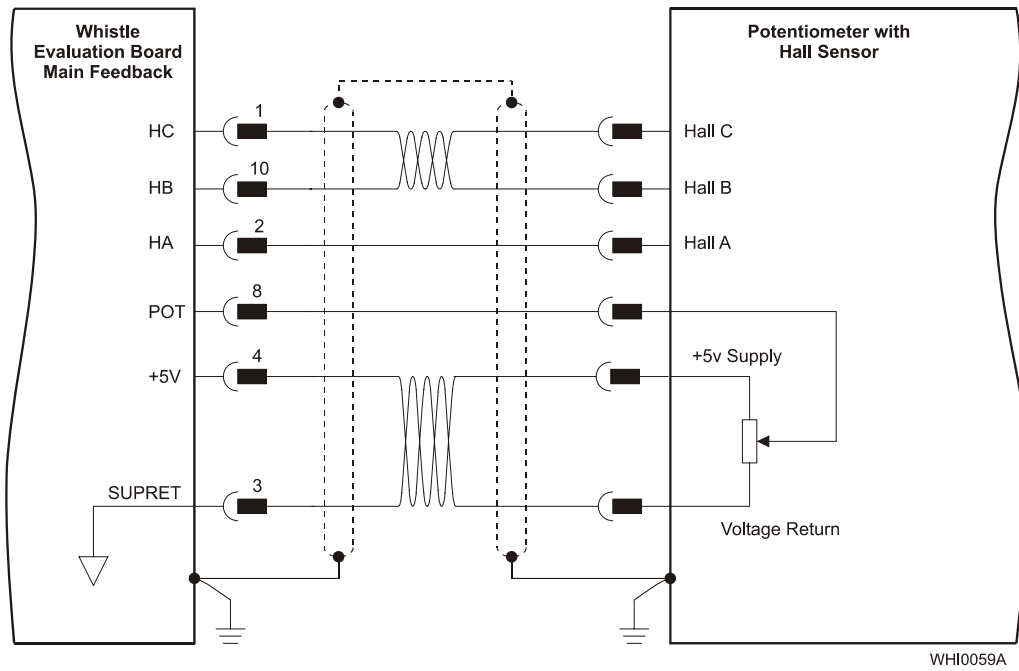

WHI0059A

Figure 2-13: Main Feedback - Potentiometer Feedback with Digital Hall Sensor Connection Diagram for Brushless Motors

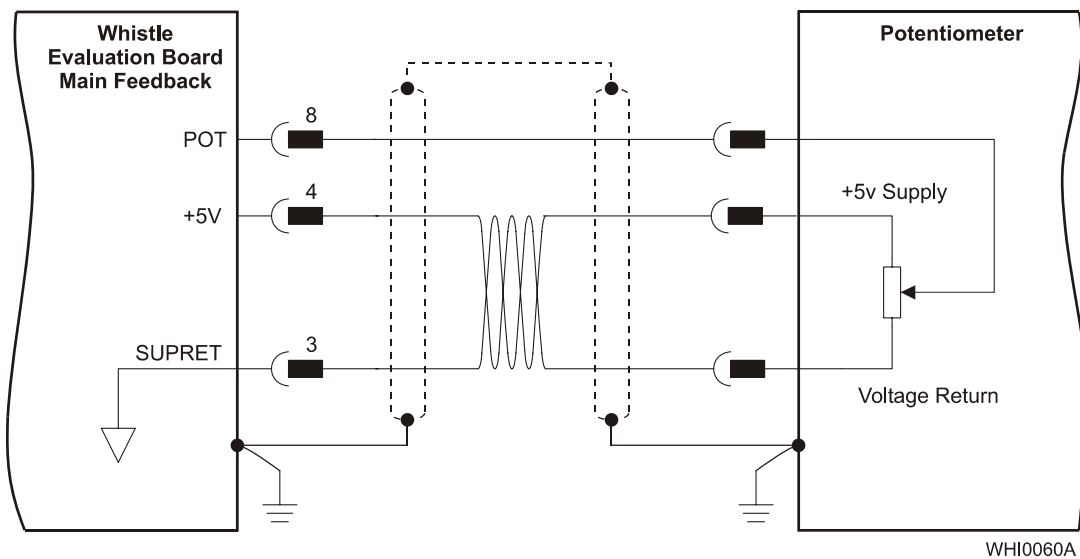

WHI0060A

Figure 2-14: Main Feedback - Potentiometer Feedback Connection Diagram for Brush Motors and Voice Coils

## 2.10 Main Buffered Output Port

This port provides Differential Buffered Outputs (of the Main Feedback) for another axis. It has a 15-pin high density D-sub socket with the following pin-outs.

Pin	Signal	Function	Pin Position
1	NC	Not connected	
2	NC	Not connected	
3	NC	Not connected	
4	NC	Not connected	
5	NC	Not connected	
6	CHAO	Channel A output	
7	CHAO-	Channel A complement output	
8	NC	Not connected	
9	NC	Not connected	
10	NC	Not connected	
11	CHBO	Channel B output	
12	CHBO-	Channel B complement output	
13	INDEXO	Index output	
14	INDEXO-	Index complement output	
15	NC	Not connected	

Table 2-5: Main Buffered Output Port - Pin Assignments

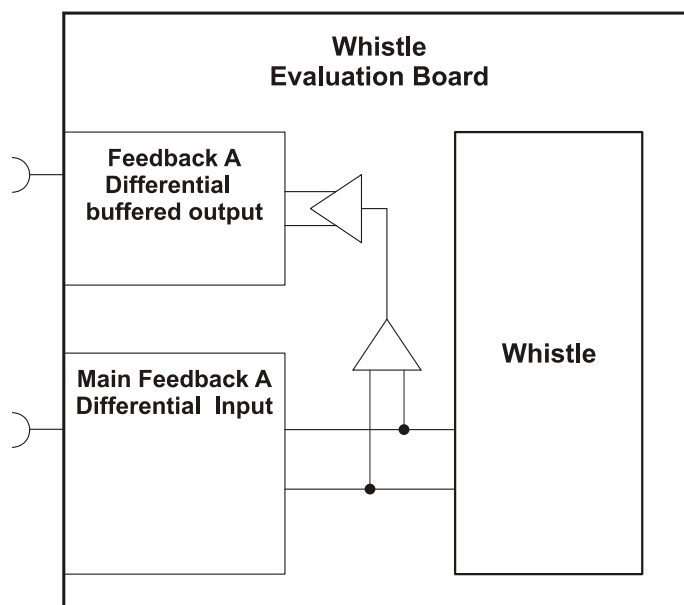

WHI0019A

Figure 2-15: Main Buffered Output Port - Block Diagram

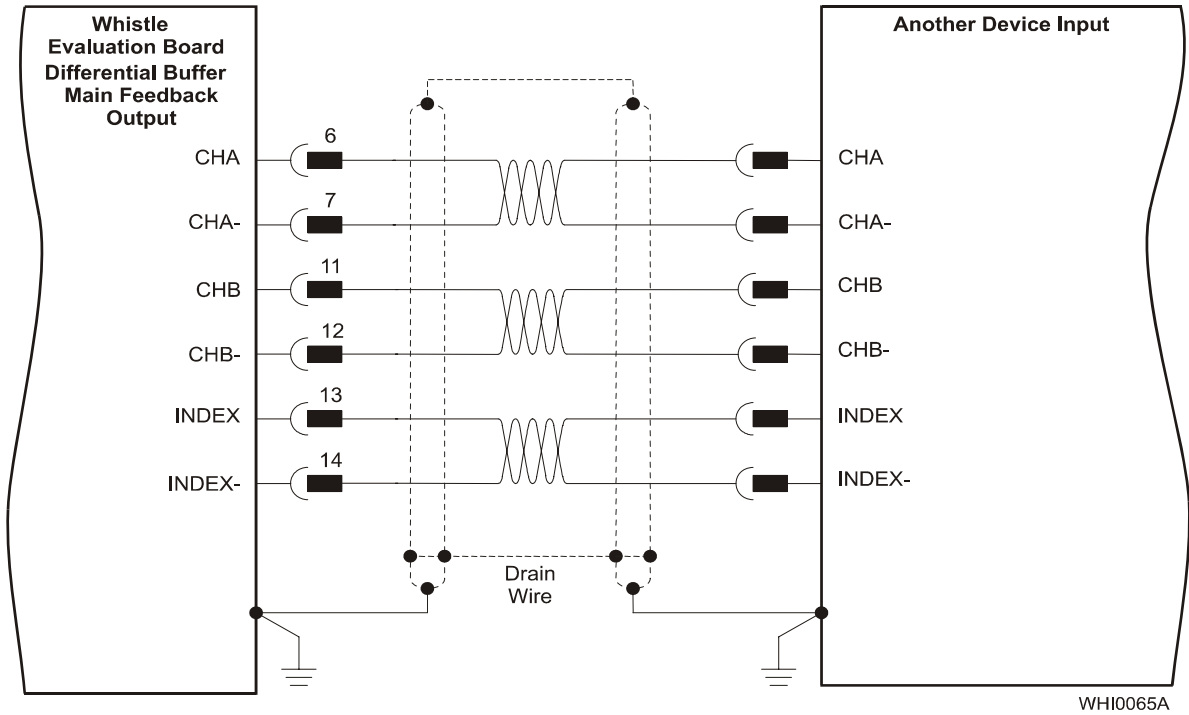

WHI0065A

Figure 2-16: Main Buffered Output Port (Differential Main Feedback Output) – Connection Diagram

## 2.11 Auxiliary Feedback (bi-directional)

When using one of the auxiliary feedback options, the relevant functionality of the AUX FEEDBACK's ports are software selected for that option. Refer to the *SimpliQ Command Reference Manual* for detailed information about Auxiliary Feedback setup.

For auxiliary feedback, one of the following options can be selected:

- a. **Emulated encoder outputs**, used to provide differential buffered emulated, encoder signals to another controller or drive. This option can be used when:
  - A Resolver or Analog Encoder is used as a main feedback device.
  - The Whistle Evaluation Board is used as a current amplifier to provide position data to the position controller.
  - The Whistle Evaluation Board is used in velocity mode, to provide position data to the position controller.
  - The Whistle Evaluation Board is used as a master in follower or ECAM mode.
- b. **Single-ended auxiliary input**, for the input of position data of the master encoder in follower or ECAM mode.
- c. **Pulse-and-direction input**, for single-ended input of pulse-and-direction position commands.

Connect the auxiliary feedback cable into the AUX FEEDBACK port on the Whistle Evaluation Board.

The Aux. Feedback connector has two ports – B1 and B2.

- **Port B1** has three single-ended Schmitt-triggered inputs
- **Port B2** has three pairs of differential buffered outputs

There are two modes of operation for this interface:

- **Mode 1 (YA[4]=4)**  
When the Auxiliary port of the Whistle is set by the software to act as an emulated encoder output ( this is practical only when using Resolver or Analog-Encoder as the main feedback):
  - B1 input becomes inactive
  - B2 presents emulated differential buffered encoder output signals of the Main Feedback
- **Mode 2 (YA[4]=2 or YA[4]=0) :**  
When the Auxiliary port of the Whistle is set by software to act as an input –
  - B1 becomes an active single-ended input
  - B2 presents differential buffered encoder output signals of B1

### 2.11.1 Main and Auxiliary Feedback Combinations

The Main Feedback is always used in motion control devices whereas Auxiliary Feedback is often, but not always used. The Auxiliary Feedback connector on the Whistle Evaluation Board has two ports (B1 and B2). When used in combination with Main Feedback, the Auxiliary Feedback can be set, by software, as follows:

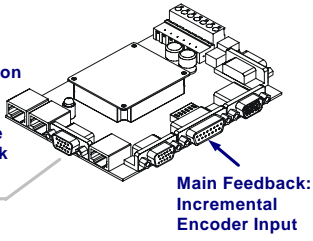
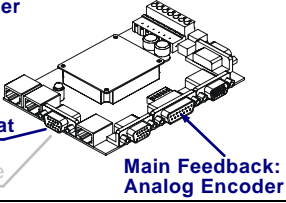
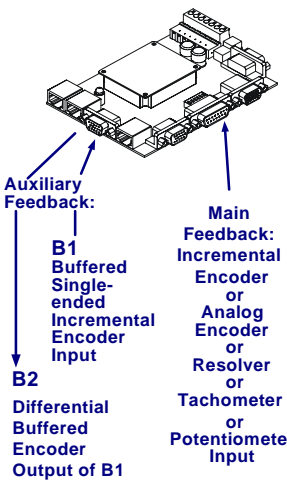
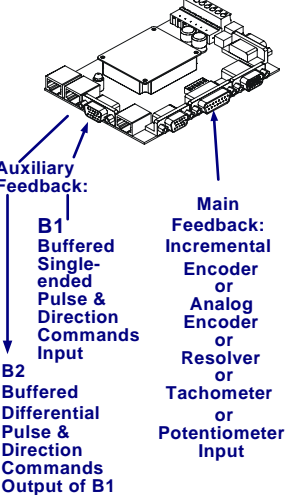
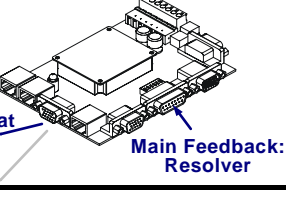
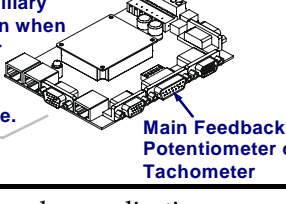
SW Setting Main Feedback	Auxiliary Feedback		
	YA[4] = 4 (Aux. Feedback: output)	YA[4] = 2 (Aux. Feedback: input)	YA[4] = 0 (Aux. Feedback: input)
<b>Incremental Encoder Input</b>	<p>There is no Auxiliary Feedback option when an Incremental Encoder is the Main Feedback device.</p>  <p>Main Feedback: Incremental Encoder Input</p>		
<b>Interpolated Analog (Sin/Cos) Encoder Input</b>	<p>★ B2 - output Analog Encoder position data emulated in Differential, buffered, incremental Encoder format</p>  <p>Main Feedback: Analog Encoder</p> <p>B1 - not available</p>	 <p>Auxiliary Feedback: B1 Buffered Single-ended Incremental Encoder Input</p> <p>Main Feedback: Incremental Encoder or Analog Encoder or Resolver or Tachometer or Potentiometer Input</p>	 <p>Auxiliary Feedback: B1 Buffered Single-ended Pulse &amp; Direction Commands Input</p> <p>Main Feedback: Incremental Encoder or Analog Encoder or Resolver or Tachometer or Potentiometer Input</p>
<b>Resolver Input</b>	<p>★ B2 - output Resolver position data emulated in differential, buffered, incremental Encoder format</p>  <p>Main Feedback: Resolver</p> <p>B1 - not available</p>	<p>B2 Differential Buffered Encoder Output of B1</p>	<p>B2 Buffered Differential Pulse &amp; Direction Commands Output of B1</p>
<b>Potentiometer Tachometer Input</b>	<p>There is no Auxiliary Feedback option when a Potentiometer or Tachometer is the Main Feedback device.</p>  <p>Main Feedback: Potentiometer or Tachometer</p>		
<b>Typical Applications</b>	<ul style="list-style-type: none"> <li>★ Analog Encoder applications where position data is required, in the Encoder's quadrature format, for other purposes such as position controllers and/or other drives.</li> <li>★ Resolver applications where position data is required in the Encoder's quadrature format, for other purposes such as position controllers and/or other drives.</li> </ul>	<p>Any application where two feedbacks are used by the drive.</p> <p>The Auxilliary Feedback port serves as an input for the auxiliary incremental encoder.</p> <p>For applications such as Follower, ECAM, or Dual Loop.</p>	<p>Any application where two feedbacks are used by the drive.</p> <p>The Auxilliary Feedback port serves as an input for Pulse &amp; Direction Commands.</p>

### 2.11.2 Auxiliary Feedback – Emulated, Differentially Buffered Encoder Output Option (YA[4]=4)

The Auxiliary Feedback's B2 port on the Whistle Evaluation Board can provide **emulated encoder signals** to other controllers or drives. This option can be used when:

- The Whistle is used as a current amplifier to provide position data to the position controller.
- The Whistle is used in velocity mode, to provide position data to the position controller.
- The Whistle is used as a master in Follower or ECAM mode.

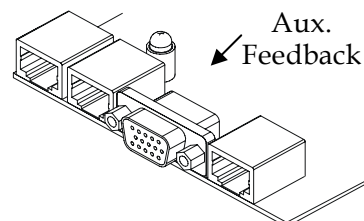

Below are the signals on the Auxiliary Feedback ports when the Whistle Aux. Feedback port is set up for emulated output of the main feedback device (Resolver or Analog Incremental Encoder only).

Port	Pin	Signal	Function	Pin Position
B1	1	NA	When YA[4]=4 the B1 port is not available	 15 Pin high density D-Sub Plug
	2	NC		
B1	3	NA	When YA[4]=4 the B1 port is not available	
	4	NC		
B1	5	NA	When YA[4]=4 the B1 port is not available	
B2	6	CHAO	Channel A output	
B2	7	CHAO-	Channel A complement output	
PWR	8	+5V	Encoder supply voltage	
PWR	9	SUPRET	Supply Return	
	10	NC		
B2	11	CHBO	Buffered channel B output	 15 Pin high density D-sub Socket
B2	12	CHBO-	Buffered channel B complement output	
B2	13	INDEXO	Buffered Index output	
B2	14	INDEXO-	Buffered Index complement output	
PWR	15	SUPRET	Supply return	

Table 2-6: Emulated Encoder Output on the Auxiliary Feedback Port B2 - Pin Assignments

The Auxiliary Feedback on the Whistle Evaluation Board has a 15-pin high density D-sub socket. Connect the Auxiliary Feedback cable, from the controller or other device, to Auxiliary Feedback using a 15-pin, high density D-Sub plug with a metal housing as on the Auxiliary Feedback cable (CBL-CELAUX-1) supplied with the Whistle Evaluation Board.

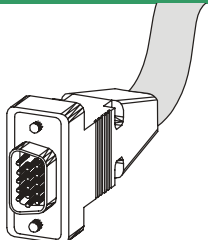
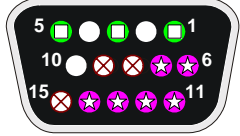
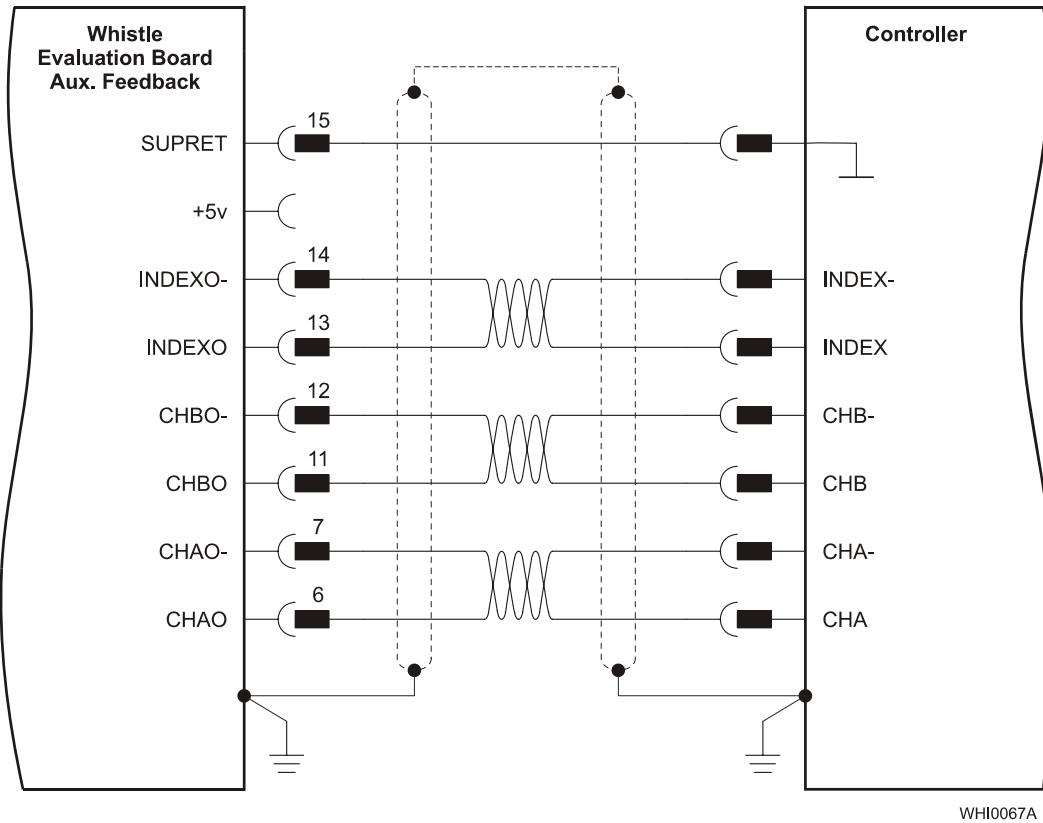

WHI0067A

Figure 2-17: Emulated Encoder Outputs of the Resolver or Analog Encoder - Connection Diagram

### 2.11.3 AUX. FEEDBACK - Single-ended Encoder Input Option (YA[4]=2)

The Whistle can be used as a slave by receiving the position data (on Port B1) of the master encoder in Follower or ECAM mode. In this mode Port B2 provides **differential buffered auxiliary outputs** for the next slave axis in Follower or ECAM mode.

Below are the signals on the Auxiliary Feedback ports when the Whistle Auxiliary Feedback port is set up to run as a single-ended auxiliary input:

Port	Pin	Signal	Function	Pin Position
B1	1	CHA	Auxiliary channel A input	 15 Pin high density D-Sub Plug
	2	NC		
B1	3	CHB	Auxiliary channel B input	
	4	NC		
B1	5	INDEX	Auxiliary Index input	
B2	6	CHAO	Channel A output	
B2	7	CHAO-	Channel A complement output	
PWR	8	+5V	Encoder supply voltage	
PWR	9	SUPRET	Supply Return	
	10	NC		
B2	11	CHBO	Channel B output	
B2	12	CHBO-	Channel B complement output	
B2	13	INDEXO	Index output	
B2	14	INDEXO-	Index complement output	
PWR	15	SUPRET	Supply return	

Table 2-7: Single-ended Auxiliary Encoder Input Option along with Differential Encoder Outputs on AUX FEEDBACK - Pin Assignments

The Auxiliary Feedback port on the Whistle Evaluation Board has a 15-pin high density D-sub socket. Connect the Auxiliary Feedback cable from the feedback device to AUX. FEEDBACK using a 15-pin, high density D-Sub plug with a metal housing as on the Auxiliary Feedback cable (CBL-CELAUX-1) supplied with the Whistle Evaluation Board.

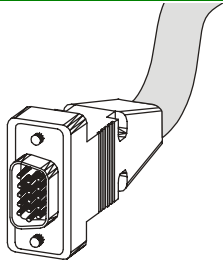
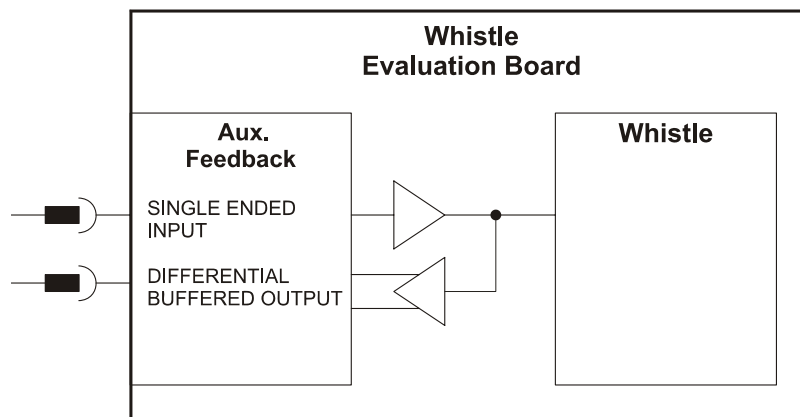

WHI0018A

Figure 2-18: Single-ended Auxiliary Input Option - Block Diagram

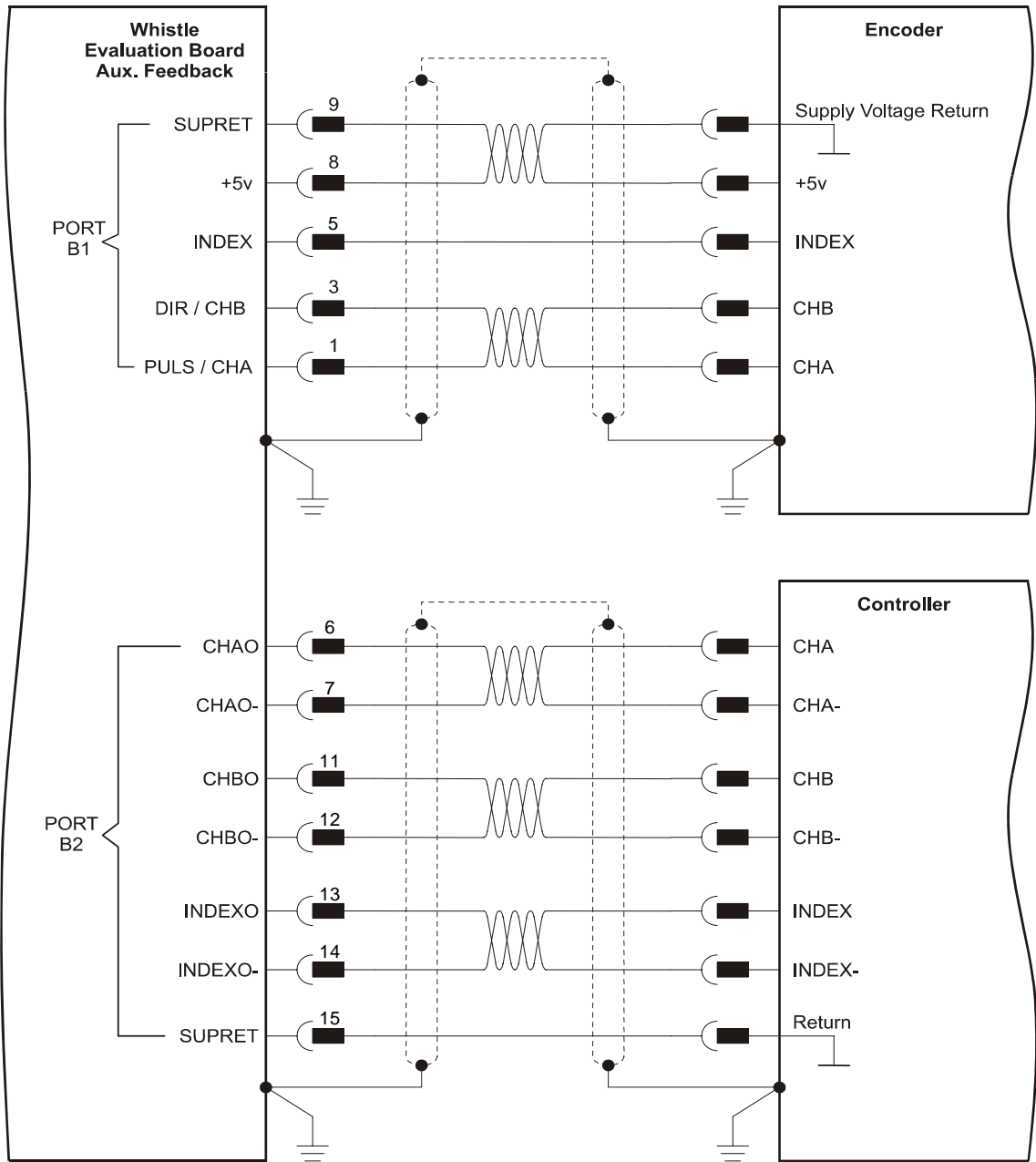

WHI0068A

Figure 2-19: Single-ended Auxiliary I/O Option on AUX FEEDBACK - Connection Diagram

### 2.11.4 AUX FEEDBACK – Single-Ended Pulse-and-Direction Input Option (YA[4]=0)

This mode is used for input of single-ended pulse-and-direction position commands on Port B1. In this mode Port B2 provides **differential buffered pulse-and-direction outputs** for another axis.

Below are the signals on the Auxiliary Feedback ports when set up to run as a single-ended differential pulse-and-direction input:

Port	Pin	Signal	Function	Pin Position	
B1	1	CHA	Auxiliary channel A <i>input</i>	 15 Pin D-Sub Plug	
	2	NC			
	B1	3	CHB		Auxiliary channel B <i>input</i>
4		NC			
5		INDEX	Auxiliary Index Input		
B2	6	CHAO	Channel A output		 15 Pin D-Sub Socket
B2	7	CHAO-	Channel A complement output		
PWR	8	+5V	Encoder/Hall supply voltage		
PWR	9	SUPRET	Encoder supply voltage return		
	10	NC			
B2	11	CHBO	Channel B output		
B2	12	CHBO-	Channel B complement output		
B2	13	INDEXO	Index output		
B2	14	INDEXO-	Index complement output		
PWR	15	SUPRET	Supply return		

Table 2-8: Pulse-and-Direction Pin Assignment on AUX FEEDBACK

AUX FEEDBACK B on the Whistle Evaluation Board has a 15-pin high density D-sub socket. Connect the Auxiliary Feedback cable from the Pulse and Direction Controller to FEEDBACK B using a 15-pin, high density D-Sub plug with a metal housing as on the Auxiliary Feedback cable (CBL-CELAUX-1) supplied with the Whistle Evaluation Board.

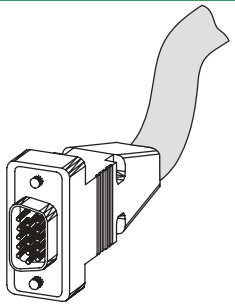
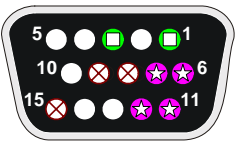
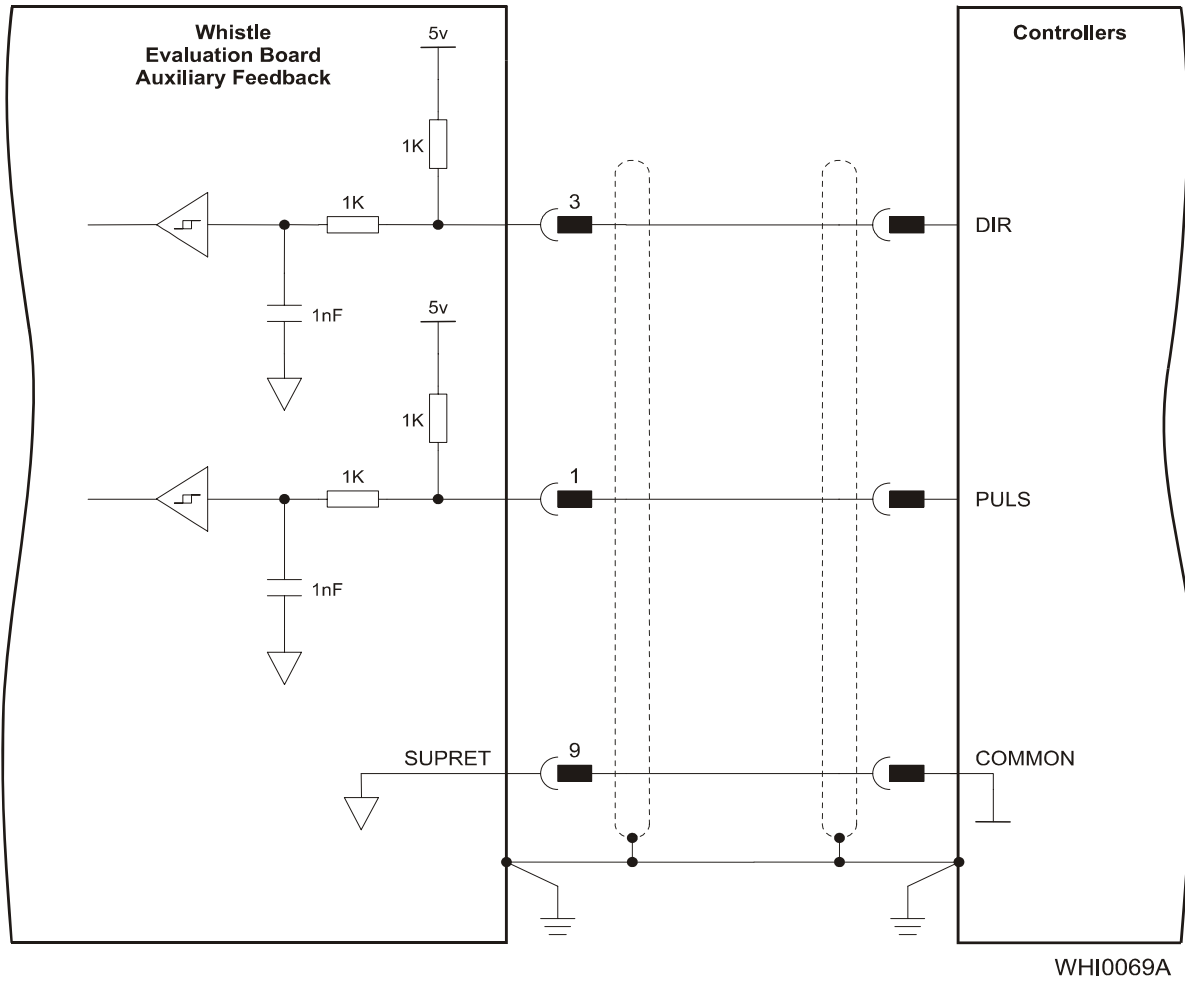

Figure 2-20: Pulse-and-Direction – Connection Diagram

## 2.12 General I/O Port

The *Whistle Evaluation Board* has 6 digital inputs, 2 digital outputs and a single analog input.

The General I/O port has a 15-pin high density D-Sub plug with the following pin-outs.

Pin	Signal	Function	Pin Position
1	IN1	Programmable input 1	
2	IN2	Programmable input 2	
3	IN3	Programmable input 3	
4	OUT2	Programmable output 2	
5	SUPRET	Supply Return	
6	IN4	Programmable input 4	
7	IN5	Programmable input 5	
8	IN6	Programmable input 6	
9	INRET	General input return	
10	OUTRET2	Programmable output return 2	
11	ANALIN1+	Analog Input 1 (positive)	
12	ANALIN1-	Analog Input 1 (negative)	
13	SUPRET	Supply Return	
14	OUT1	Programmable output 1	
15	OUTRET 1	Programmable output return 1	

Table 2-9: General I/O Port and Cable - Pin Assignments

### 2.12.1 Digital Input & DIP Switch Settings

Digital Input can be configured in one of 2 ways:

- When the controller's signal level is ~24v - the 6 DIP switches must be set to OFF (open).
- When the controller's signal level is ~5v - the 6 DIP switches must be set to ON (closed).

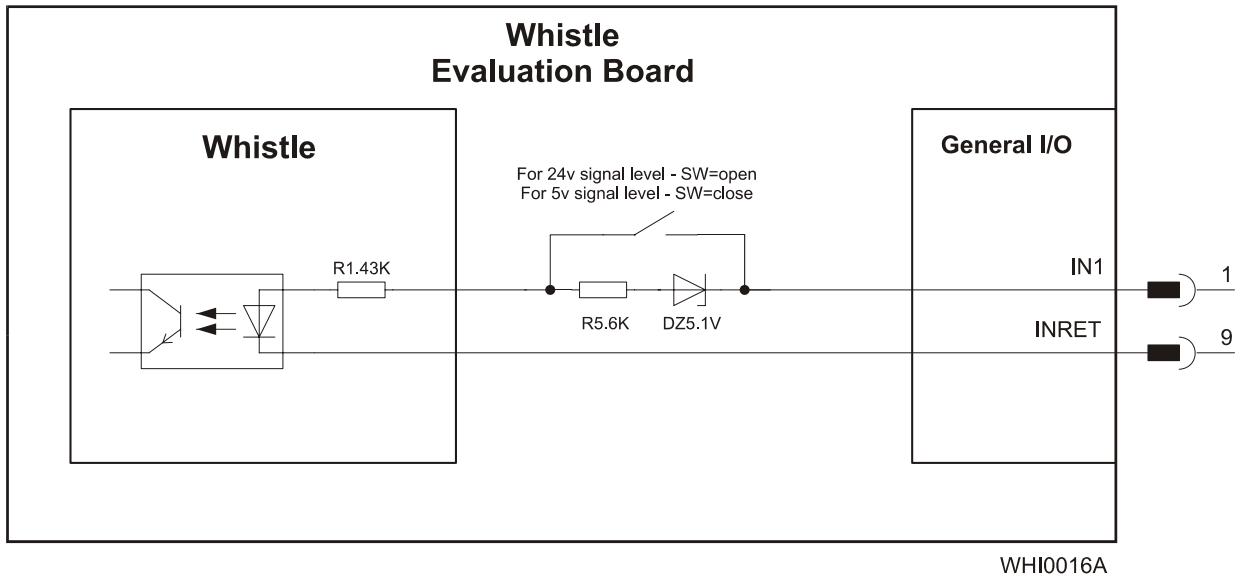

Figure 2-21: Connection Diagram of a Typical Digital Input (1 of 6 DI)

### 2.12.2 Digital Output

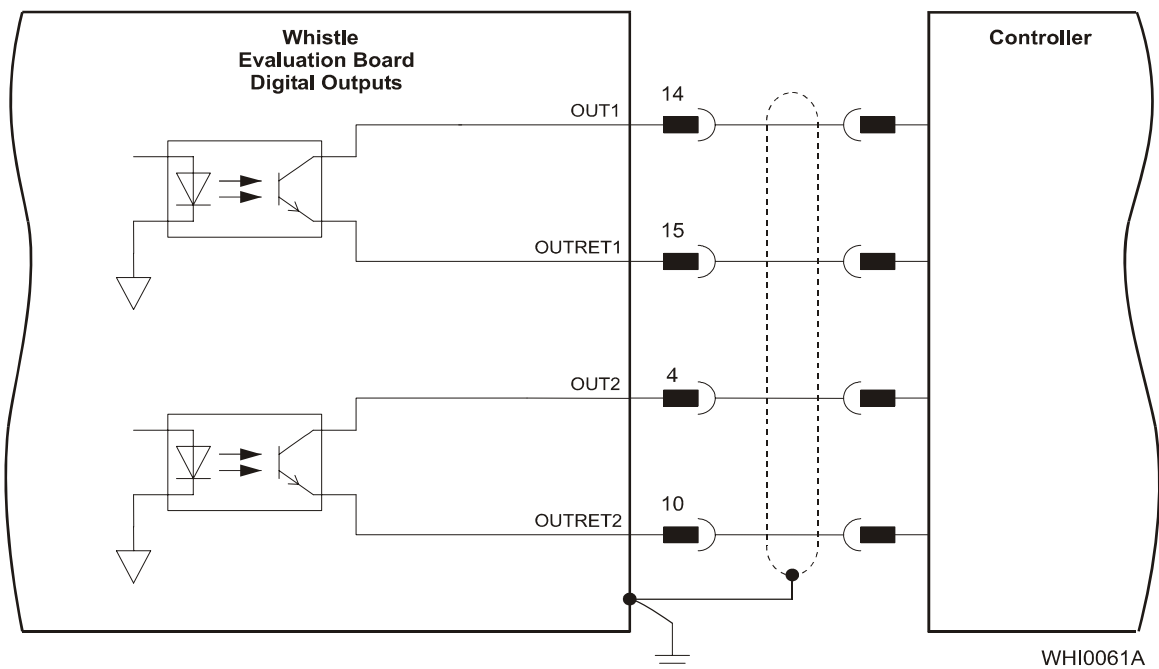

Figure 2-22: Digital Output Connection Diagram

### 2.12.3 Analog Input

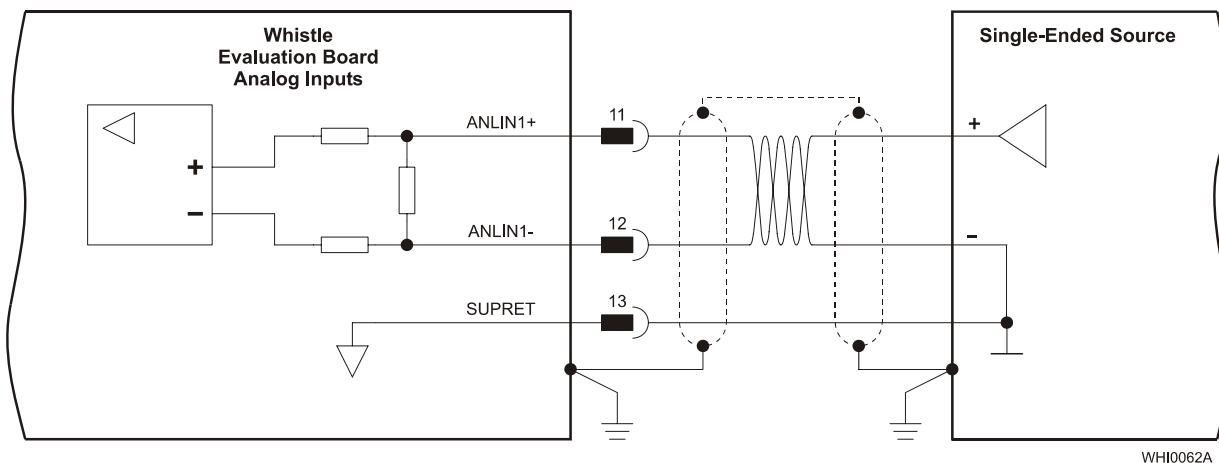

Figure 2-23: Analog Input with Single-ended Source

## 2.13 Communications

The communication cables use an 8-pin RJ-45 plug that connect to the RS-232 and CANopen ports on the Whistle Evaluation Board.

The communication interface may differ according to the user's hardware. The Whistle Evaluation Board can communicate using the following options:

- a. RS-232, full duplex
- b. CANopen

**RS-232** communication requires a standard, commercial 3-core null-modem cable connected from the Whistle Evaluation Board to a serial interface on the PC. The interface is selected and set up in the Composer software.

In order to benefit from **CANopen** communication, the user must have an understanding of the basic programming and timing issues of a CANopen network.

For ease of setup and diagnostics of CAN communication, RS-232 and CANopen can be used simultaneously.

### 2.13.1 RS-232 Communication



**Notes for connecting the RS-232 communication cable:**

- Connect the shield to the ground of the host (PC). Usually, this connection is soldered internally inside the connector at the PC end. You can use the drain wire to facilitate connection.
- The Whistle Evaluation Board's RS-232 communications port is **non-isolated**.
- The male RJ plug must have a shield cover.
- Ensure that the shield of the cable is connected to the shield of the RJ plug. The drain wire can be used to facilitate the connection.

Pin	Signal	Function	Pin Location
1	—	—	
2	—	—	
3	Tx	RS-232 transmit	
4	—	—	
5	COMRET	Communication return	
6	Rx	RS-232 receive	
7	—	—	
8	—	—	

Table 2-10: RS-232 Cable - Pin Assignments

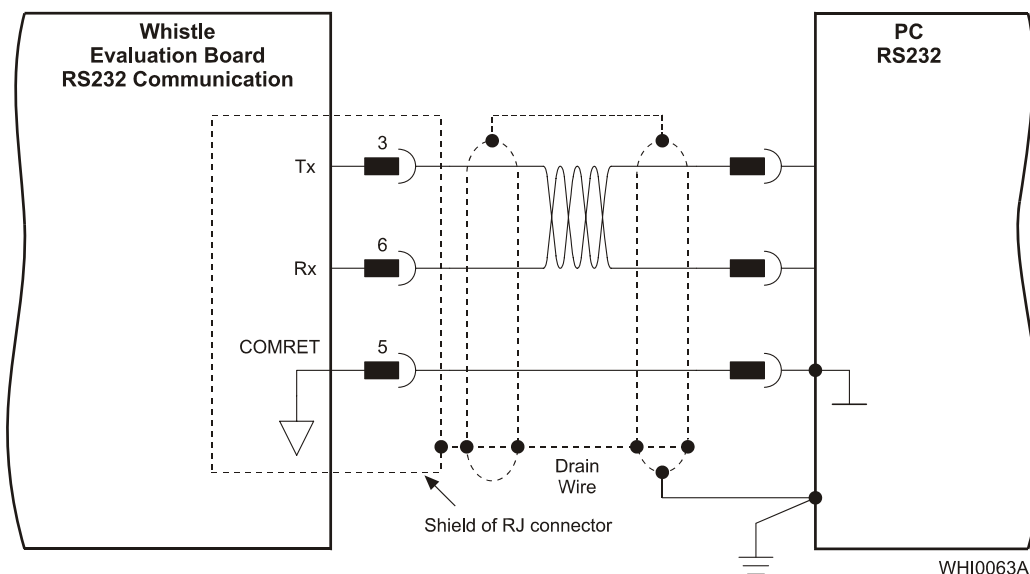

Figure 2-24: RS-232 Connection Diagram

## 2.13.2 CANopen Communication



### Notes for connecting the CANopen communication cable:

- For "daisy-chain" connections use 26 or 28 AWG twisted pair shielded cables. For best results, the shield should have aluminum foil and covered by copper braid with a drain wire
- Connect the shield to the ground of the host (PC). Usually, this connection is soldered internally inside the connector at the PC end. You can use the drain wire to facilitate connection.
- The Whistle Evaluation Board's CANopen ports are **non-isolated**.
- The male RJ plug must have a shield cover.
- Ensure that the shield of the cable is connected to the shield of the RJ plug. The drain wire can be used to facilitate the connection.
- Connect a termination 120-ohm resistor at each of the two ends of the network cable.

Pin	Signal	Function	Pin Position
1	CAN_H	CAN_H busline (dominant high)	
2	CAN_L	CAN_L busline (dominant low)	
3	CAN_GND	CAN ground	
4	—	—	
5	—	—	
6	CAN_SHLD	Shield, connected to the RJ plug cover	
7	CAN_GND	CAN Ground	
8	—	—	

Table 2-11: CANopen Cable - Pin Assignments

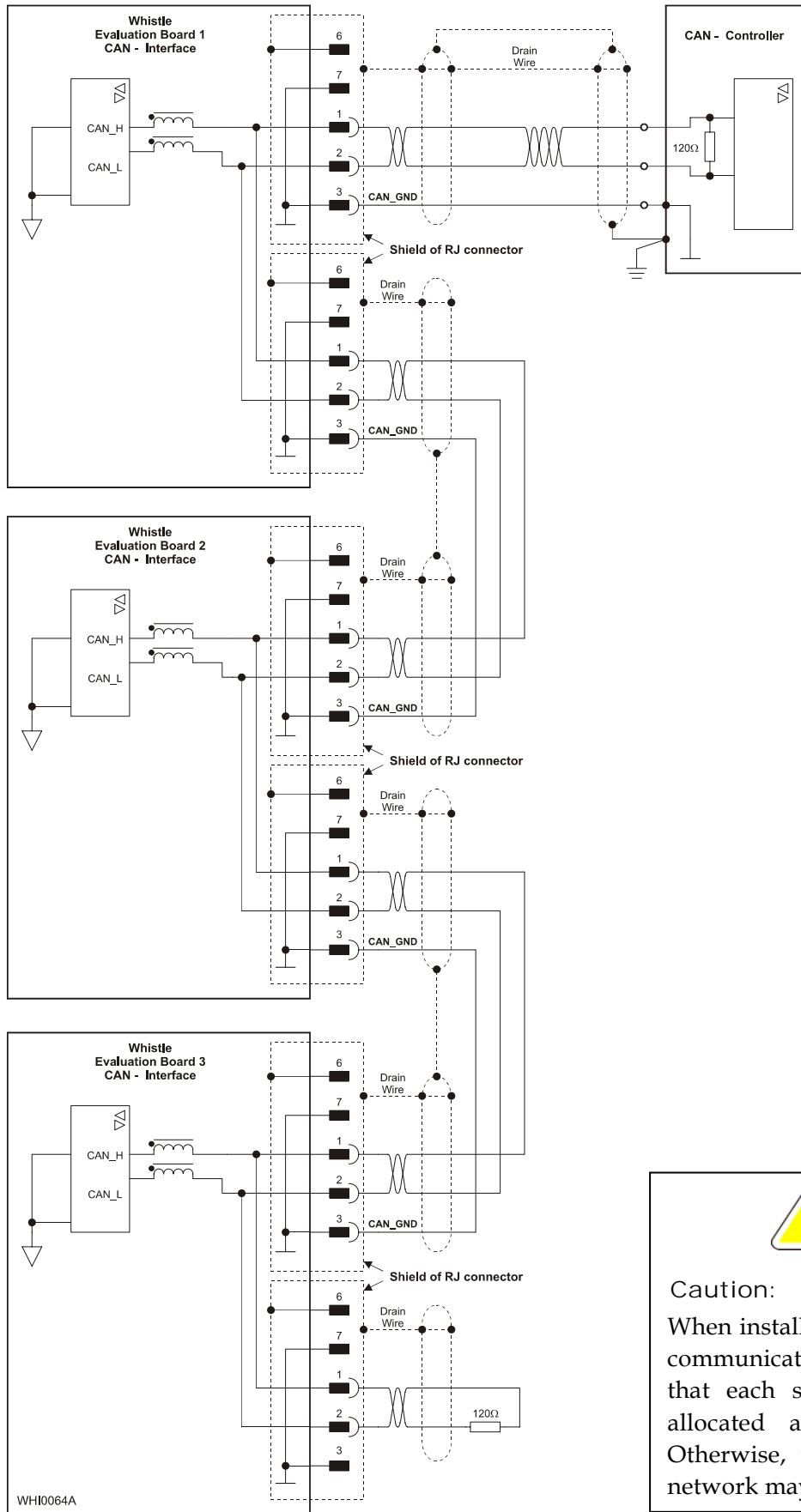

**Caution:**  
 When installing CANopen communications, ensure that each servo drive is allocated a unique ID. Otherwise, the CANopen network may hang.

Figure 2-25: CANopen Connection Diagram

## 2.14 Powering Up

After the Whistle is mounted on the Whistle Evaluation Board and the cables have been connected to their devices, the Whistle Evaluation Board is ready to be powered up.



Caution:

Before applying power, ensure that the DC supply is within the specified range and that the proper plus-minus connections are in order.

## 2.15 Initializing the System

After the Whistle Evaluation Board has been connected and mounted, the system must be set up and initialized. This is accomplished using the *Composer*, Elmo's Windows-based software application. Install the application and then perform setup and initialization according to the directions in the *Composer Software Manual*.

# Appendix: Cables

## A.1 Cable Photos

 <p><b>Main Feedback:</b>      <b>CBL-DFDBK-1</b></p>	 <p><b>Aux. Feedback &amp; Main Buffered Output:</b>      <b>CBL-CELAUX-1</b></p>
 <p><b>General I/O:</b>      <b>CBL-CELIO1-1</b></p>	
 <p><b>Motor Power Cable:</b>      <b>CBL-MTRPWR3-1</b></p>	 <p><b>Aux. Power:</b>      <b>CBL-CEL24-1</b></p>
 <p><b>RS-232 Com.:</b>      <b>CBL-RJ452321-1</b></p>	 <p><b>CAN Com.:</b>      <b>CBL-RJ45CAN1-1</b></p>

## A.2 Cable Kits

A full set of cables is supplied with the Evaluation Board. The cables are all 1m in length. Each set contains the cables listed below. Additional Cable Kits and individual cables (individually or in multiples of 10 each) are available from Elmo.

<b>Cable Application</b>	<b>Cable Part. No.</b>
Main Feedback	CBL-DFDBK-1
Auxiliary Feedback	CBL-CELAUX-1
Main Buffered Output	CBL-CELAUX-1
General I/O	CBL-CELIO1-1
Motor Power	CBL-MTRPWR3-1
Auxiliary Power	CBL-CEL24-1
RS-232 Communications	CBL-RJ452321-1
CAN Communications	CBL-RJ45CAN1-1

### A.3 Main Feedback Cable (CBL-DFDBK-1)

The Main Feedback cable (CBL-DFDBK-1) is made of 24-AWG shielded cable with a 15-pin D-sub plug. It connects to the MAIN FEEDBACK port on the Evaluation Board. It is open on the motor side so that it can be connected to customer-specific connectors.

Pin No.	Color	Pairs	
1	Green	pair	 <p>15 Pin D-sub Plug</p>
10	Yellow		
2	Pink		
3	White	pair	
4	Brown		
5	Orange	pair	
6	Cyan		
7	Blue	pair	
8	Red		
9	-		
11	-		
12	-		
13	-		
14	Black	pair	
15	Purple		



Figure A-1: Single-sided Main Feedback Cable (Part No. CBL-DFDBK-1)

## A.4 Auxiliary Feedback and Main Buffered Output Cable (CBL-CELAUX-1)

CBL-CELAUX-1 is a 24-AWG shielded cable with a 15-pin High-Density D-sub plug. It can be connected to the Evaluation Board's AUX. FEEDBACK port or its MAIN BUFFERED OUTPUT port.

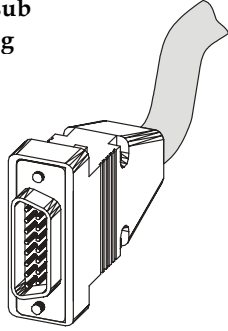
Four options, described in the *Auxiliary Feedback* section are available for auxiliary feedback (this is in addition to a fifth option described in the *Main Buffered Output Port* section):

- Main encoder buffered outputs
- Differential encoder inputs
- Single-ended encoder input
- Pulse-and-direction input

The general pinout of this cable is as follows:

Pin	Color	Pair	Pin Position
1	Cyan	pair	 <p>15 Pin high density D-Sub Plug</p>
2	Orange		
3	Purple	pair	
4	Black		
5	Red	pair	
10	Blue		
6	Pink	pair	
7	Grey		
8	Brown	pair	
9	White		
11	Yellow	pair	
12	Green		
13	White/Red	pair	
14	White/Black		
15	White/Yellow		



Figure A-2: Auxiliary Feedback Cable (Part No. CBL-CELAUX-1)

## A.5 General I/O (CBL-CELIO1-1)

The digital input cable is a 24-AWG shielded cable. It is connected using a 15-pin Hi-Density D-sub socket.

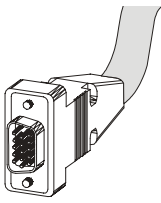
Pin	Color	Signal	Pair	Function	Pin Position
1	Orange	IN1	pair	Programmable input 1	
2	Cyan	IN2		Programmable input 2	
3	Purple	IN3	pair	Programmable input 3	
8	Black	IN6		Programmable input 6	
4	Grey	OUT2	pair	Programmable output 2	
5	Pink	SUPRET		Supply Return	
6	Blue	IN4	pair	Programmable input 4	
7	Red	IN5		Programmable input 5	
9	White/ Yellow	INRET		General input return	
10	White/ Red	OUTRET2	pair	Programmable output return 2	
12	White/ Black	ANALIN1-		Analog input -	
11	Yellow	ANALIN1+	pair	Analog input +	
13	Green	SUPRET		Supply return	
14	Brown	OUT1	pair	Programmable output 1	
15	White	OUTRET 1		Programmable output return 1	



Figure A-3: General Purpose I/O Cable (Part No. CBL-CELIO1-1)

## A.6 Motor Power Cables (CBL-MTRPWR3-1)

CBL-MTRPWR3-1 is a general-purpose motor power cable. It is made from 24-AWG shielded wires with pin terminals on the Evaluation Board end. The pins are connected to the Pheonix plug supplied with the board. The other end is open so that it can be attached to a customer-specific connector.

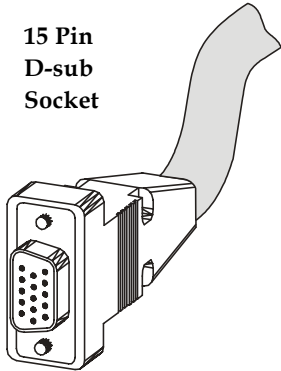
Color	Signal	Description
Brown + White	M1	Motor Phase 1 (U)
Red + Blue	M2	Motor Phase 2 (V)
Pink + Grey	M3	Motor Phase 3 (W)
Green + Yellow	PE	Ground



Figure A-4: General-Purpose Motor Power Cable (Part No. CBL-MTRPWR3-1) & plug

## A.7 Auxiliary Power Cable (CBL-CEL24-1)

The auxiliary power cable is a 24-AWG shielded cable terminated by pins. The pins are screwed into the 2-pole Pheonix plug provided with the Whistle Evaluation Board.

Pin No.	Color	Twisted & Shielded Wire	Signal	Description
1	Red	Pair	VL	Auxiliary Supply input
2	Black		PR	Supply Input Return



Figure A-5: Auxiliary Power Cable (Part No. CBL-CEL24-1) & Plug

## A.8 Communication Cables

The communication cables use 26-AWG twisted pair shielded cable. They are connected using an 8-pin RJ-45 plug. Elmo drives can communicate using the following options:

- RS-232, full duplex
- CANopen

### A.8.1 RS-232 Option (CBL-RJ452321-1)

RJ45 Pin No.	Color	D-type Female Pin No.	Signal	Description
3	Brown	2	Tx	RS-232 transmit
5	White	5	COMRET	Communication return
6	Green	3	Rx	RS-232 receive
body	Drain Wire	body	shield	cable shield

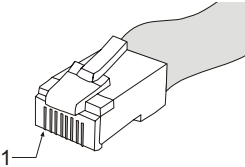



The shields of the RJ-45 and D-type plugs are connected to each other through the cable braid.



Figure 6: RS-232 Communications Cable (Part No. CBL-RJ452321-1)

### A.8.2 CAN Option (CBL-RJ45CAN1-1)

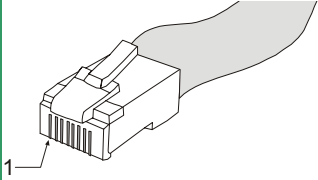
RJ45 Pin No.	Color	D-type Female Pin No.	Signal	Description
1	Green	7	CAN-H	CAN_H bus line
2	Yellow	2	CAN_L	CAN_L bus line
3	White	3	CAN_GND	CAN ground
4	—	—	—	—
5	—	—	—	—
7	—	—	—	—
8	—	—	—	—
body	Drain Wire	body	shield	cable shield



The shields of the RJ-45 and D-type plugs are connected to each other through the cable braid.



Figure 7: CAN Cable (Part No. CBL-RJ45CAN1-1)

## A.9 Guidelines for Making Your Own Cables

Proper wiring, grounding and shielding are essential for ensuring safe, immune and optimal servo performance of the Whistle Evaluation Board. If you do not plan to use cables provided by Elmo, follow the instructions below carefully.



Follow these instructions to ensure safe and proper wiring:

- Use twisted pair shielded cables for control, feedback and communication connections. For best results, the cable should have an aluminum foil shield covered by copper braid, and should contain a drain wire.  
*The drain wire is a non-insulated wire that is in contact with parts of the cable, usually the shield. It is used to terminate the shield and as a grounding connection.*
- The impedance of the wire must be as low as possible. The size of the wire must be thicker than actually required by the carrying current. A 24, 26 or 28 AWG wire for control and feedback cables is satisfactory although 24 AWG is recommended.
- Use shielded wires for motor connections as well. If the wires are long, ensure that the capacitance between the wires is not too high:  $C < 30 \text{ nF}$  is satisfactory for most applications.
- Keep all wires and cables as short as possible.
- Keep the motor wires as far away as possible from the feedback, control and communication cables.
- Ensure that in normal operating conditions, the shielded wires and drain *carry no current*. The only time these conductors carry current is under abnormal conditions, when electrical equipment has become a potential shock or fire hazard while conducting external EMI interferences directly to ground, in order to prevent them from affecting the drive. Failing to meet this requirement can result in drive/controller/host failure.
- After completing the wiring, carefully inspect all wires to ensure tightness, good solder joints and general safety.

### A.9.1 Recommended Wire Cross Sections

Function	Connection	Details
Motor	PE, M1, M2, M3	24 AWG
Auxiliary power	VL, PR	24 AWG
Feedback and Control	MAIN FEEDBACK AUX FEEDBACK GENERAL I/O MAIN BUFFERED OUTPUT	24 AWG twisted pair shielded cables as described below (Section A.9.2)
Communications	RS-232 CANopen	26 AWG twisted pair shielded cables as described below (Section A.9.2)

### A.9.2 Feedback and Control Cable Assemblies

The Whistle Evaluation Board features easy-to-use D-sub type connections for all Control and Feedback cables. Below are instructions and diagrams describing how to assemble those cables.

- Use 24, 26 or 28 AWG twisted-pair shielded cables (24 AWG cable is recommended). For best results, the shield should have aluminum foil covered by copper braid.
- Use only a D-sub connector with a **metal housing**.
- Attach the braid shield tightly to the metal housing of the D-type connector.
- On the motor side connections, ground the shield to the motor chassis.
- On controller side connections, follow the controller manufacturer's recommendations concerning the shield.

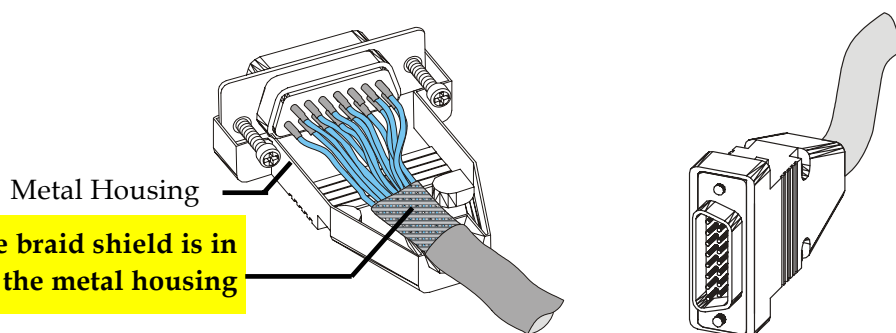

Figure A-8: Feedback and Control Cable Assemblies



**Note:** All D-sub connectors, used with the Evaluation Board, should be assembled in this way.