



**HR8**  
**Ultrasonic Motor**  
**User Manual**

**P/N MSP8-M00-M00-40**



## CE Compliance

The LN-2000 family drivers and motors complies to the following directive:

Safety : IEC 61010-1:1990

EMC : 89/336/EEC as amended by 92/31/EEC and 93/68/EEC

Harmonized Standards to which conformity is declared:

EN 50081- 2:1993/EN 55011:1991

Generic Emission Standards Class A for radiated emission and Class B for conducted emission.

EN 50082- 2:1995 Generic Immunity Standard

**NOTE:** *UHV motors are designed for convenient interface to the UHV setup. The motors are therefore supplied with three open electrical leads. Whereas standard motors comply with CE regulations and the UHV motors have the same internal design as standard motors, the UHV motors are supplied as components and CE conformity in both EMI and Safety must be implemented as part of the UHV system design.*

## Copyright

April 2000. This document contains proprietary information of Nanomotion, Ltd. and may not be reproduced in any form without prior written consent from Nanomotion Ltd.

## Preface

This Installation Manual is designed to help the reader install and operate the various types of Nanomotion's HR8 Piezoceramic Motors. This manual assumes that the reader has a fundamental understanding of basic servo systems, as well as motion control concepts and applicable safety procedures.

The manual describes the physical dimensions as well as the mechanical and electrical installation procedures for these motors.

## Warranty

The motors are covered by warranty for a period of twelve months from the date of invoice.

The following voids the warranty:

Misuse or incorrect mounting, incorrect electrical connections, removal of motor cover or of serial number, modification of parts, and any other use that is not according to the cautions and warnings provided in this guide.

Liability for replacement will be determined after inspection of any defective item by Nanomotion or an approved agent.

## Patents

Aspects of the HR8 motors and relevant applications are protected by the following patent and patent applications:

- US 5453653
- US 5714833
- US 5696421
- US 5616980
- US 5682076

## Definition of Terms

**NOTE:** *Additonal usefull information.*

**CAUTION:** *Identifies conditions or practices that could result in damage to this product or other property.*

 **WARNING:** *Identifies conditions or practices that could result in personal injury, damage to the product or other property.*

## Warnings and Cautions

### **WARNINGS**

***Do not remove the cover of the motor or disassemble its connector. High voltage inside.***

***Be sure to ground the motor to the electrical network ground (according to the following instructions) before operating the motor.***

### **CAUTIONS**

- *Arrows on motor indicate direction of motion. Align accordingly.*
- *Do not set power-on unless motor is mounted and preloaded!*
- *Do not immerse the motor in any liquid or cleaning agent.*
- *Use only a clean cloth to wipe the motor.*
- *Be sure that the motor, and specifically the 'finger tips', are not subjected to mechanical shocks.*
- *Be sure that the distance of the motor to the plate enables the motor finger tip to contact the driving plate, otherwise the motor might be damaged during operation.*
- *The mounting base and the method used for mounting should be designed for maximum mechanical rigidity and stiffness.*
- *Reducing the length of the supplied motor cable may damage the motor. Do not attempt to shorten the cable without prior confirmation from Nanomotion.*
- *Extending the motor cable will not damage the motor, however it will affect its performance.*

---

## Table of Contents

<b>1. INTRODUCTION .....</b>	<b>1-1</b>
<b>1.1 About the Motor .....</b>	<b>1-1</b>
<b>1.2 Vacuum Motors.....</b>	<b>1-1</b>
<b>1.3 HR8 System Parts.....</b>	<b>1-2</b>
<b>1.4 Handling.....</b>	<b>1-2</b>
<b>1.5 Installation and Servicing .....</b>	<b>1-2</b>
<b>2. PREPARATION AND INSTALLATION .....</b>	<b>2-1</b>
<b>2.1 Preparation.....</b>	<b>2-1</b>
2.1.1 Mounting Base .....	2-2
2.1.2 Limiting Stage Motion.....	2-3
<b>2.2 Motor Installation.....</b>	<b>2-4</b>
2.2.1 Bonding the Driving Plate to the Stage .....	2-4
2.2.2 Mounting the Motor .....	2-7
2.2.3 Motor Grounding .....	2-9
2.2.4 Motor Connections .....	2-10
2.2.4.1 Motor Connector Pinout.....	2-10
2.2.4.2 System Electrical Configuration.....	2-11
2.2.5 Motor Run-In .....	2-12
<b>3. SPECIFICATIONS.....</b>	<b>3-1</b>
<b>3.1 General.....</b>	<b>3-1</b>
<b>3.2 Specification Parameters .....</b>	<b>3-3</b>
3.2.1 Performance.....	3-3
3.2.2 Electrical .....	3-3
3.2.3 Environmental .....	3-3
3.2.4 Physical Dimensions .....	3-3
3.2.5 Performance Envelope.....	3-4
<b>3.3 Schematics .....</b>	<b>3-5</b>
3.3.1 Dimensions for Standard and High-Vacuum Motors.....	3-6
3.3.2 Dimensions for Ultra-High-Vacuum Motors.....	3-7
3.3.3 Mounting Base Dimensions.....	3-8

# 1. Introduction

---

## 1.1 About the Motor

The HR8 motors are high precision ceramic motors belonging to the Nanomotion LN2000 product line. Designed and manufactured by Nanomotion, Ltd., the HR8 motors, combine unlimited stroke with high resolution in compact dimensions. Among its applications are microscopy, precision motion, robotics, etc.

The motors provide a linear response to the input voltage. The operation of the motor and driver resembles that of a DC-motor driven by a voltage amplifier.

The specifications described in this chapter apply only to the motor driven by the AC-1 Driver Card and the AB-1 driver box. Minor differences may result if NCD Controller Driver, DC-12 Driver Card, or DB-121/122 Driver Box are used.

## 1.2 Vacuum Motors

Applications of the Nanomotion motors for vacuum and high-vacuum environments include wafer inspection and metrology, scanning stages and lithography. The HR8-V and HR8-U motors are constructed of materials that have been selected and designed for high vacuum compatibility.

## 1.3 HR8 System Parts

A complete set for a single axis will comprise of the following:

- a) HR8 Motor
- b) Ceramic Driving Plate for linear applications or Ceramic Driving Ring/Disk for rotary applications (see section 2.2.1)
- c) LC-Box (Tank Circuit)
- d) One of the following drivers:
  - AC-1 Driver Card
  - AB1
  - DC-12 Driver Card
  - DB-121 or 122 Driver Box
  - NCD Driver Controller Box

**NOTE:** For the first 4 driver options, use a standard off-the-shelf DC Controller with a servo rate of 10KHz or more. You may consult Nanomotion for the recommended controller. The option for NCD Driver Controller Box consists of a driver and an integrated controller.

## 1.4 Handling

### **CAUTIONS**

*Do not set power-on unless the motor is mounted and preloaded!*

*Do not immerse the motor in any solvent or cleaning agent.*

*Use only a clean cloth to wipe the motor.*

*Be sure that the motor, and specifically the 'finger tips', are not subjected to mechanical shocks.*

## 1.5 Installation and Servicing

It is recommended to follow the installation instructions in this guide, when mounting and installing the motor. The HR8 does not contain any user-serviceable parts.

## 2. Preparation and Installation

---

### 2.1 Preparation

For optimal motor performance, it is recommended to use the Ceramic driving plate provided by Nanomotion. These driving plates have been specifically designed to work with Nanomotion motors.

Substituting this plate with any other material might reduce motor performance or damage the motor.

**NOTE:** The instructions given in this section refer to the standard ceramic driving plates provided by Nanomotion. Nanomotion can not guarantee performance attained by plates purchased from other sources.

### 2.1.1 Mounting Base

Prepare the base as described in Section 3.3.3 - Mounting Base Dimensions. The base should be positioned perpendicular to the Ceramic driving plate that is bonded to the stage.

If necessary, refer to the schematic for motor dimensions.

**CAUTION:** *The mounting base and the method used for mounting should be designed for maximum mechanical rigidity and stiffness.*

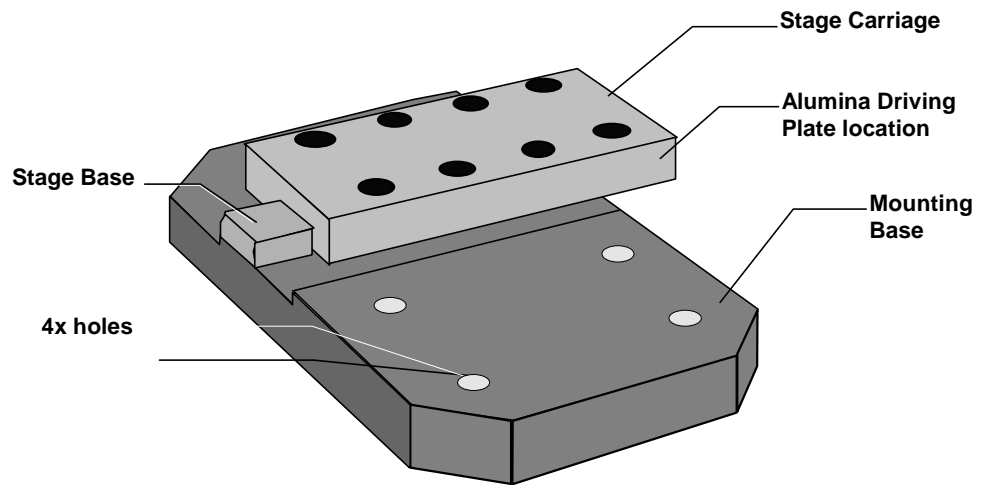

Figure 2-1: Motor Mounting Base

The mounting base dimensions diagram refers to the *front* surface of the Ceramic driving plate.

For driving plate dimensions please refer to the price list.

The four screws securing the motor to the mounting surface will be inserted from its underside. Any protrusion of the screws *might* interfere with motion on another axis.

### 2.1.2 Limiting Stage Motion

The provided ceramic driving plate should not exceed the stage. It must be supported by a solid even backing along all its length, in order to avoid breaking when motor is pressed against it.

The Ceramic driving plate should also be at least 20 mm longer than the stage travel length, otherwise the motor finger tips might be damaged.

If the above requirements are not met, limit the stage travel distance using end stops.

## 2.2 Motor Installation

The installation procedure consists of:

- Bonding the Ceramic Driving plate to the stage
- Mounting the motor
- Grounding the motor
- Connecting the motor to its driver

### 2.2.1 Bonding the Driving Plate to the Stage

The Driving Ceramic Plate interfaces between the motor 'finger tips' and the stage, and provides the required friction.

Bond the driving plate to the stage surface interfacing with the motor 'finger tips', according to the instructions given in this section.

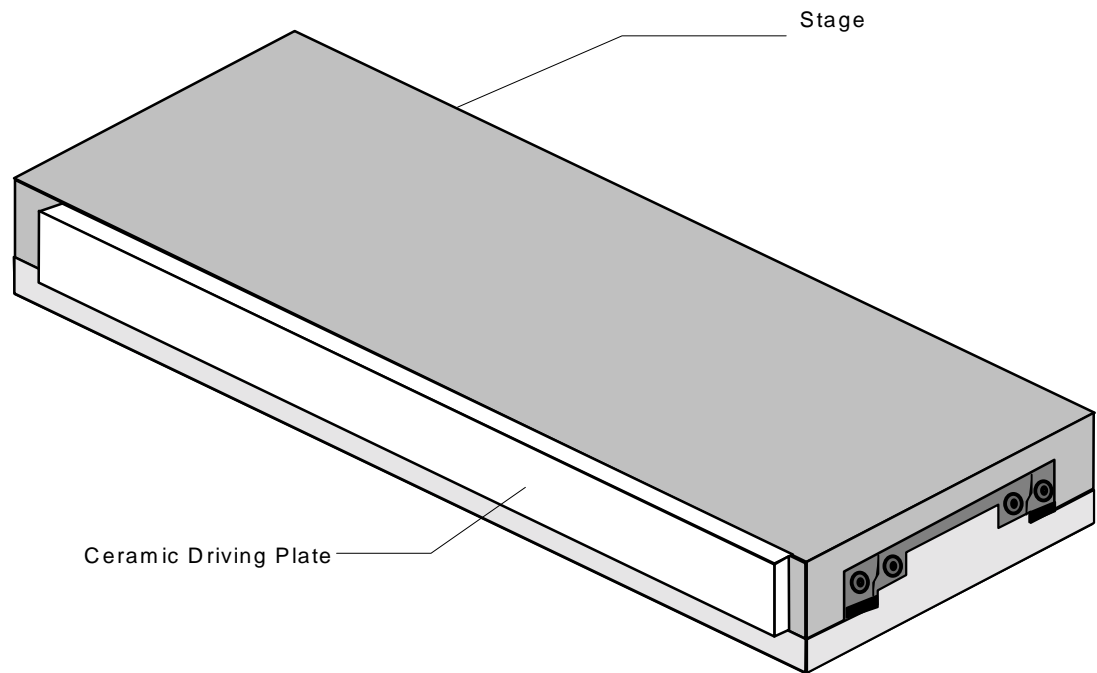

*Figure 2-2: Bonding the Ceramic Driving Plate*

1. Clean the bonding region on the stage, using a suitable agent such as Acetone or Methanol.
2. Peel off the self-adhesive backing paper on the Ceramic driving plate. The self adhesive tape is compatible with high-vacuum applications.
3. Referring to the figure below, place the plate in position, verifying that:
  - There is a maximum of 3.5mm between the lower edge of the Ceramic driving plate and the motor mounting surface.
  - There is a minimum of 21mm between the upper edge of the Ceramic driving plate and the motor mounting surface.

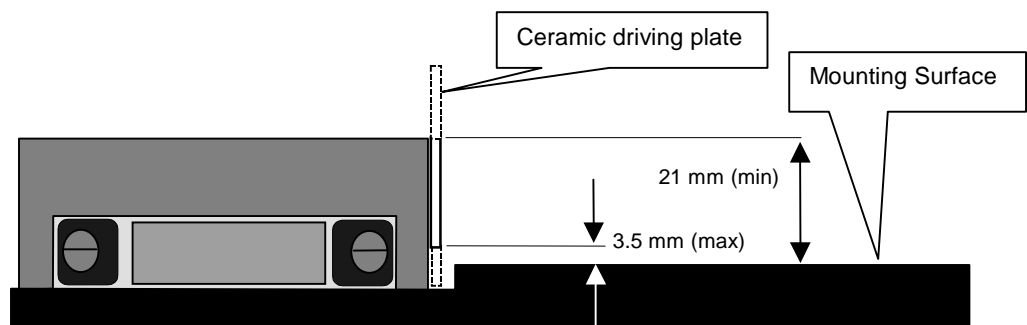

Figure 2-3: Ceramic Driving Plate Position

Continued on the following page....

- Referring to the figure below, apply two drops of epoxy adhesive, on the center of the Ceramic driving plate *upper* surface, about 2cm apart. The Epoxy must bond between the plate and the stage.

Recommended adhesive:

- Emerson & Cuming ecobond 24, for vacuum applications
- 3M 2216 epoxy or CIBA GEIGY Arldite Radite, for non-vacuum applications

**NOTE:** Be sure the epoxy contacts the upper surfaces of the plate and the stage carriage but does not flow over the Ceramic plate front surface.

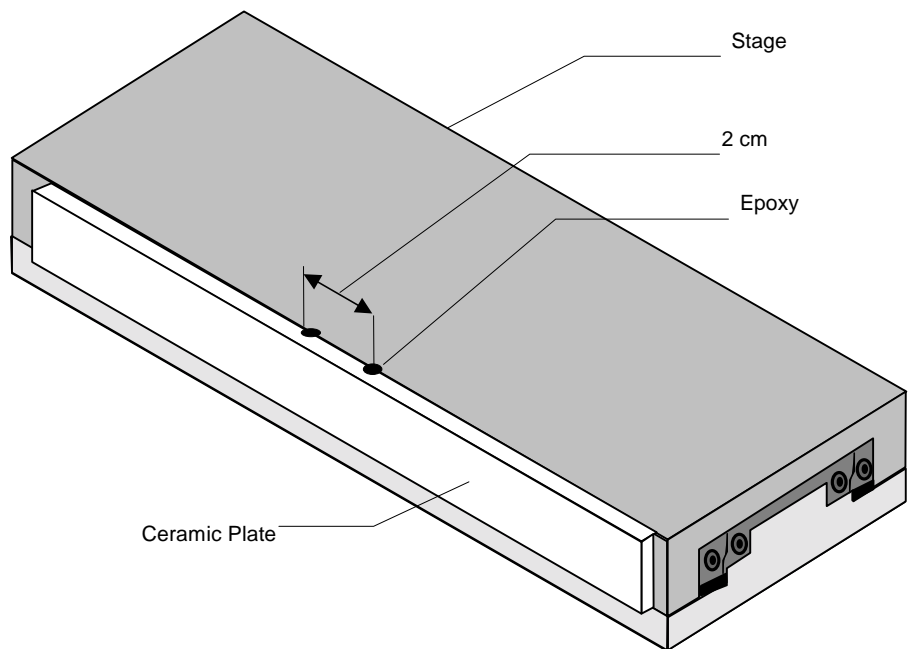

Figure 2-4: Securing the Ceramic Driving Plate to the Stage

- Allow the required time period for curing, according to the Epoxy manufacturer specifications.
- Mount the motor according to the following section.

## 2.2.2 Mounting the Motor

1. Preload the motor: using a 3mm flat screwdriver, turn both of the two preload setting screws counter-clockwise until the turn is completed and the slot is in the position illustrated below.

**NOTE:** the motor is usually supplied with the preload screws already at the preloaded position. If so, please continue to step 2.

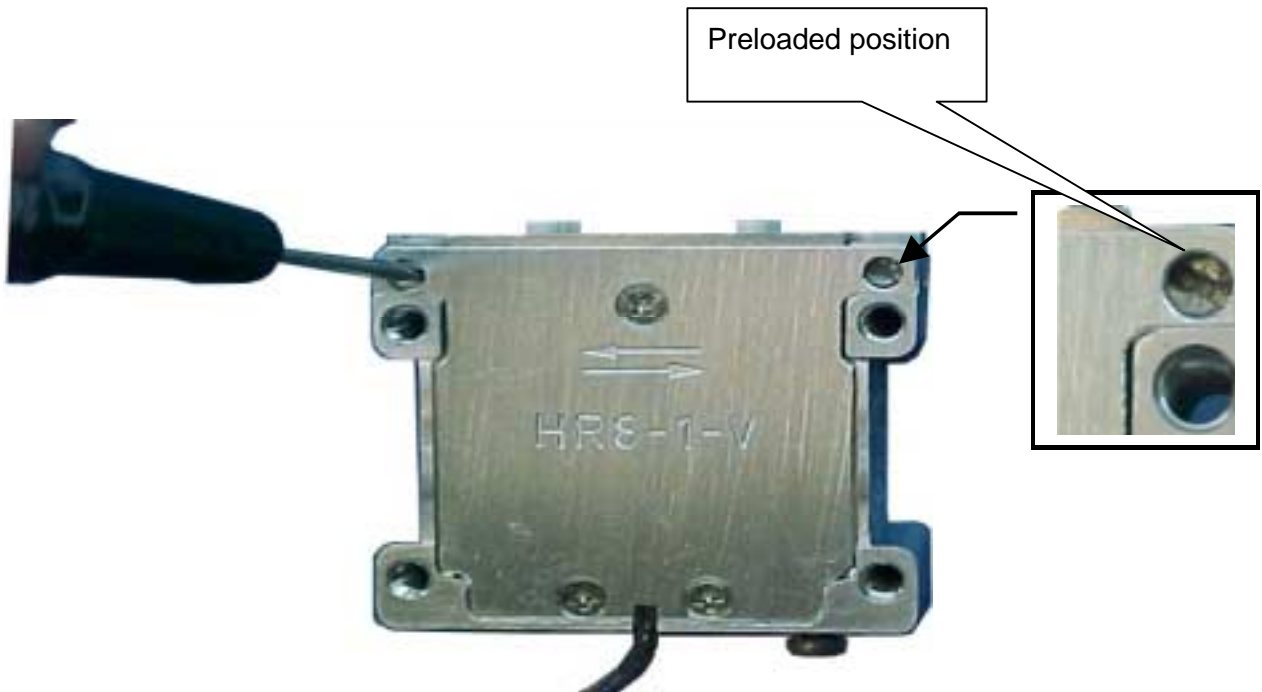

*Figure 2-5: Non-preloaded Position*

*Continued on the following page...*

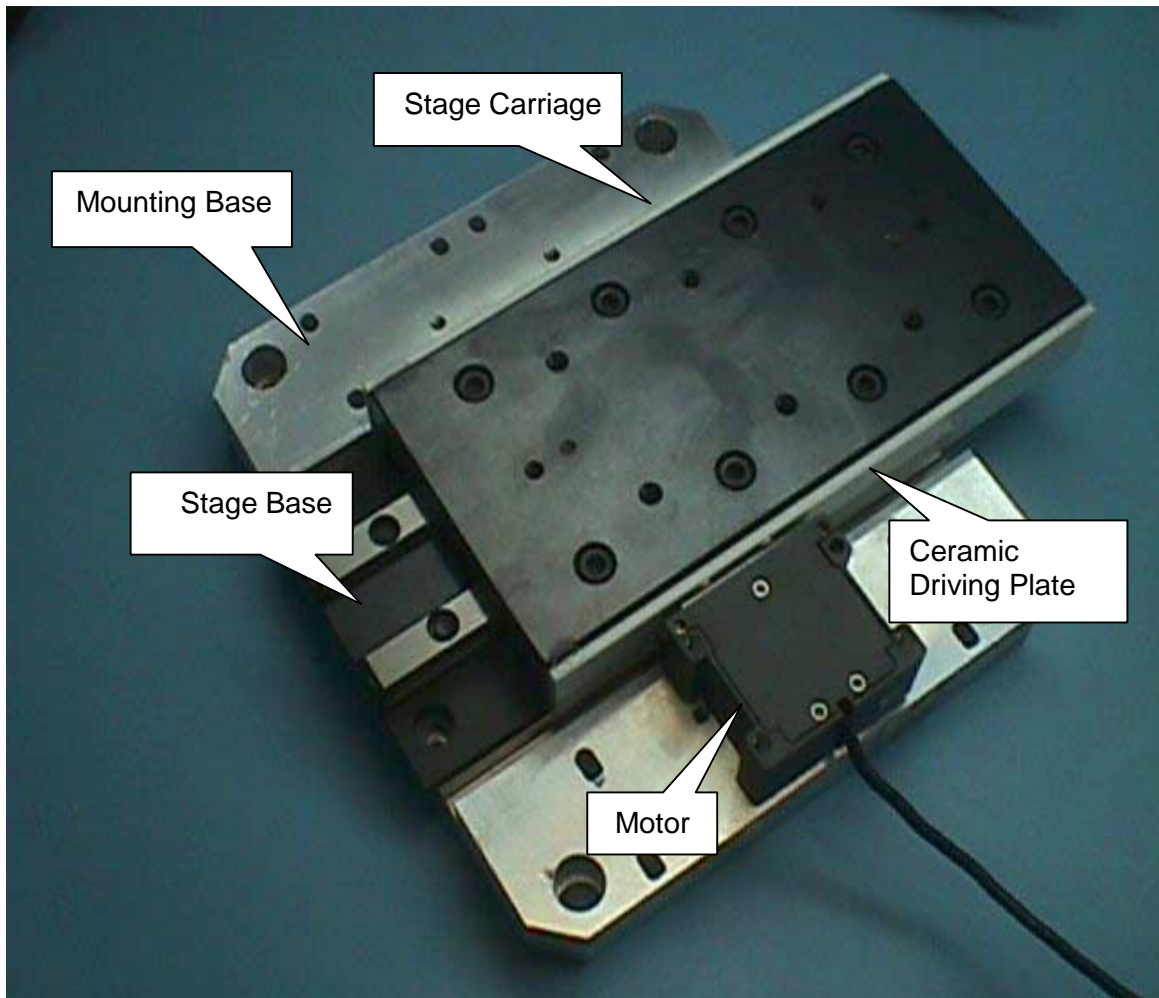

Figure 2-6: Mounting the Motor

2. While making sure not to exert any force on the fingers, place the motor on the mounting base and loosely secure it using four M4 screws and spring washers inserted from the underside of the mounting base. **Do not tighten yet.**
3. *Gently* press the motor against the ceramic driving plate, until it just contacts it and **tighten** the four screws of Step-2 at a torque of 0.5 - 0.7 Nm.

4. Release the preload setting screws: using again the 3mm flat screwdriver, turn both screws *clockwise* until the turn is completed and the slot is in the position illustrated below. The motor is now preloaded against the ceramic drive plate.

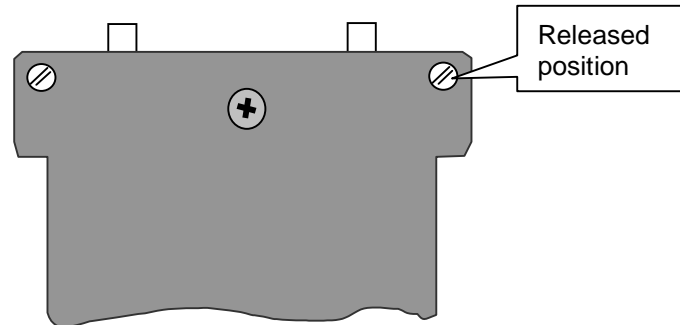

Figure 2-7: Released Position

5. Ground the motor according to the following section.

### 2.2.3 Motor Grounding

 **Warning !!!**

***Be sure to ground the motor to the electrical network ground (according to the following instructions) before operating the motor.***

1. Prepare a grounding wire and terminal connection with the following specifications:
  - Terminal diameter - for an M3 screw
  - Wire diameter - minimum 18 AWG
  - Wire length - maximum of 2 meter
2. Open the motor ground screw (figures 3-5 & 3-6) and connect the Ground connection prepared in step-1.
3. Secure the terminal between the two lock washers.
4. Connect the other end of this cable to the electrical network ground.
5. Connect the motor to its driver according to the instructions given in the following section.

## 2.2.4 Motor Connections

This section describes the motor connector pinout and the connections to each of the available drivers. Make sure the driver is set to operate with the HR8 motor series.

### CAUTIONS:

*Reducing the length of the supplied motor cable may damage the motor. Do not attempt to shorten the cable without prior confirmation by Nanomotion.*

*Extending the motor cable will not damage the motor, however it will affect its performance.*

### 2.2.4.1 Motor Connector Pinout

**⚠ WARNING:** Do not remove the cover of the motor or disassemble its connector. High voltage inside.

**CAUTION:** Do not set power-on unless the motor is mounted and preloaded.

The motor driver connection is a standard 9 contacts D-type female connector whose pinout is given below.

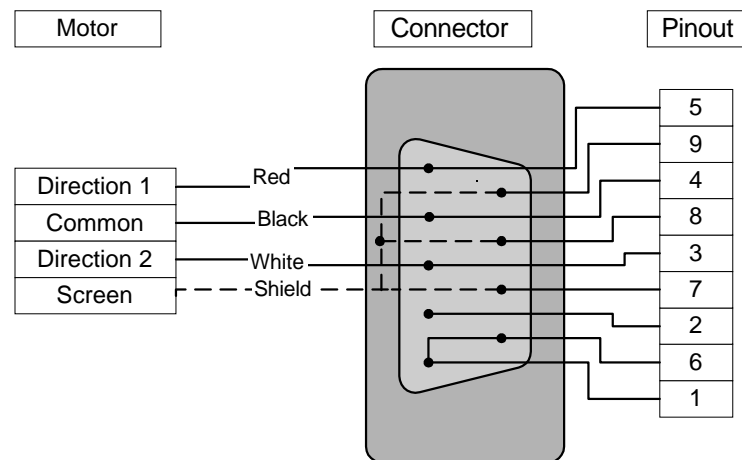

Figure 2-8: Motor Connector

**NOTE:** Pins 6 and 1 on the motor connector are shorted. This is done for safety reasons – driver voltage is disabled unless pins 1 & 6 are shorted when motor is connected.

### For Ultra High Vacuum motor:

The HR8 –1-U motor does not have an outlet cable or a connector. Instead, there are 3 TFE jacketed wires extending outside the motor: 1 black wire, 1 red and 1 white wire. The red and white wires are direction 1 and 2 respectively, and the black wire is the common. Also, the safety shorting between pins 1 and 6 is not implemented and should be preformed by the user.

 **WARNING**

***Since there is no cable shielding the HR8-1-U motor case to ground, it must be grounded by means of connection to the network ground. Please refer to section 2.2.3 in the manual for detailed instructions.***

#### 2.2.4.2 System Electrical Configuration

The Motor is to be operated by one of Nanomotion's drivers.

Following is the two possible configurations:

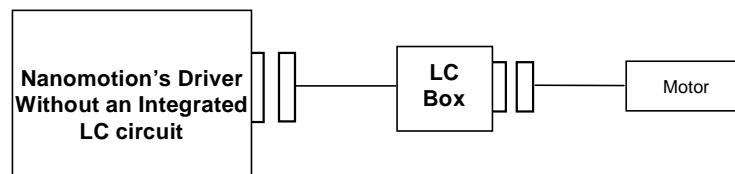

*Figure 2-9: Connection to a driver using an external LC box*

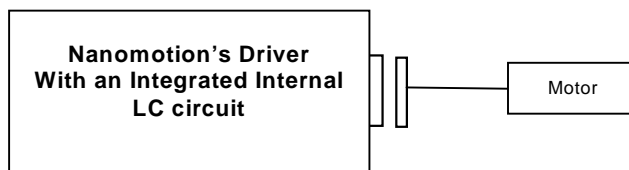

*Figure 2-10: Connection to a Driver with internal LC circuit*

## 2.2.5 Motor Run-In

Run-in of the motor is important to reduce wear rate of the system and to increase its lifetime.

The required run-in conditions are as follows:

- velocity - 50 mm/sec.
- Duty cycle - 50%.
- Duration - 4 hours.

When the run-in is completed, carefully clean the ceramic strip with a Q-Tip soaked with IPA, **without dismounting the motor**.

### **General remarks:**

1. The procedure should be repeated if the motor is disconnected and then reinstalled.
2. **Do not perform run-in in a vacuum environment.**

## 3. Specifications

---

### 3.1 General

These specifications apply to the standard motor driven by the AB1 Driver Box. The motor features a linear voltage response. The motor and driver can be modeled as a DC-motor with friction driven by a voltage amplifier, as illustrated in the following diagram. .

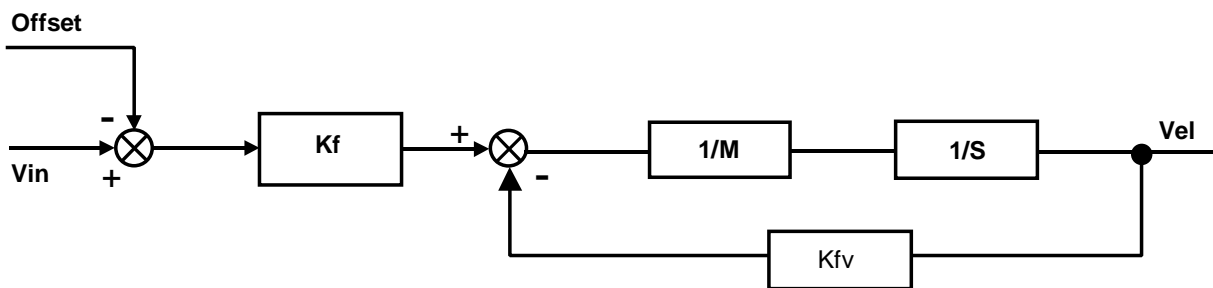

Figure 3-1: Block Diagram of the Motor and Driver

Where:

- $V_{in}$  - Command to the driver -10 to +10 [V]
- $K_f$  - Force constant [N/V]
- $Offset$  - Starting voltage [V]
- $K_{fv}$  - Velocity damping factor  
(similar to back EMF) [N x sec / m]
- $Vel$  - Motor velocity [m/Sec]
- $M$  - Moving mass [kg]
- $S$  - Laplace variable [1/sec]

A block diagram of a typical HR8 Driver/Motor Sub-system is shown below.

A command voltage of  $\pm 10V$  is applied to the driver. The driver then generates a 39.6Khz sine wave ( $V_{motor}$ ) whose amplitude is a function of command voltage. The sine wave drives the HR8 motor.

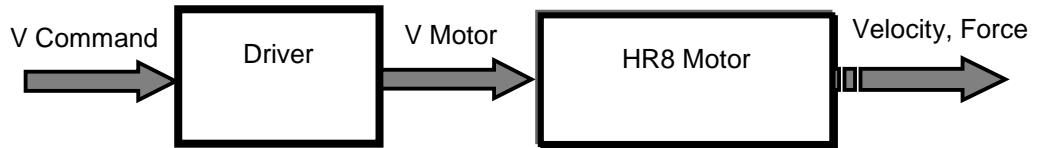

*Figure 3-2: Block Diagram of a typical HR8 Driver/Motor Sub-system*

## 3.2 Specification Parameters

### 3.2.1 Performance

Maximum Allowable Velocity:	250 [mm/sec]
Dynamic Stall Force:	30 to 36 [N]
Static Holding Force	28 [N] (reference value)
Non-Energized Stiffness	3.3 to 3.8 [N/ $\mu$ ]
Nominal Preload on Stage	144 [N]
Kf	4 to 8 [N/Volt] - driver & command dependant
Kfv	120 to 144 [N • sec/m]
Offset	1 to 2 [V] – driver dependant
Attainable Resolution	Better than 100nm – see application notes.
Nominal Lifetime	20,000 hours under nominal operating conditions

### 3.2.2 Electrical

Maximal Voltage:	270Vrms, 39.6KHz, sine wave.
Maximal Current consumption:	600 mA rms
Maximal Power Consumption:	30W

### 3.2.3 Environmental

Ambient Temperature:	0 - 50°C
Storage:	-20°C - +70°C
Humidity:	0 - 80% non condensing
Vacuum level (high-vacuum motors):	$10^{-7}$ Torr (guaranteed only after baking)
Vacuum level (ultra-high-vacuum motors):	$10^{-10}$ Torr (guaranteed only after baking)
Maximum Baking Temperature (for vacuum motors):	120°C (140°C for ultra high vacuum motor)

### 3.2.4 Physical Dimensions

Length:	41.9mm
Width:	46.6mm
Height:	23.8mm
Weight:	120/170 gr. (high & ultra high vacuum motors /standard motor)

### 3.2.5 Performance Envelope

The following graph illustrates motor velocity as a function of the applied driver command voltage. Allowing up to 30 mm/sec variations, use it as a reference and as a guideline for expected motor performance,

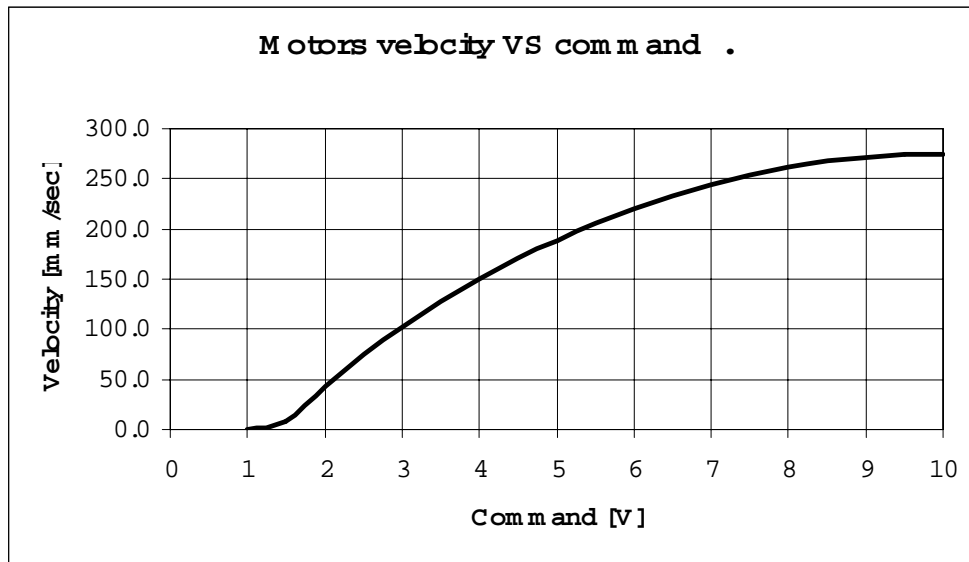
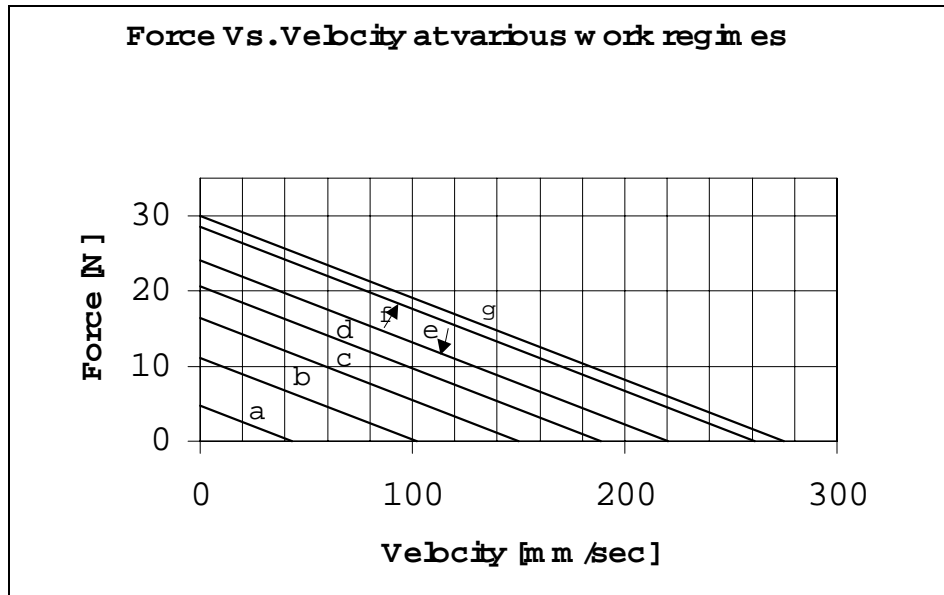

Figure 3-3: Motor Velocity vs. Command<sup>1</sup>

<sup>1</sup> The motor operates horizontally at room temperature and low duty cycle (< 10%). It interfaces an Ceramic Strip (according to Nanomotion Specifications) and a cross-roller high quality slide.

The following graph and table are designed to help the user determine the correct performance envelope of operation so as to not overheat and damage the motor.



Curve	25 °C		50 °C		Vacuum	
	Duty Cycle	max. continuous operation time	Duty Cycle	max. continuous operation time	Duty Cycle	max. continuous operation time
a	100%	-	100%	-	100%	-
b	100%	-	100%	-	44%	184
c	100%	-	92%	137	26%	107
d	100%	-	62%	93	17%	72
e	78%	87 seconds	47%	70	13%	55
f	56%	62 seconds	33%	50	9%	39
g	50%	56 seconds	30%	45	8%	35

Figure 3-4: Performance envelope at various work regimes

### How to define a performance envelope

An example for using the graph and table:

A vacuum application requires 10N at a velocity of 100mm/sec. The graph shows that this point of operation corresponds to the curve “d”.

The table shows that curve “d” and a vacuum environment require that a duty cycle of 17% will not be exceeded while maintaining a maximum continuous operation time of 72 seconds.

**Vacuum application note** – Heat dissipation mechanism is by radiation to the motor case and by conduction through the fingers. Hence, the motor and the ceramic drive strip bases, must both be thermally designed to dissipate 2W each (per motor), with a temperature rise of 15°C maximum. Also, the temperature of all parts in contact with the motor and with the ceramic drive strip, should not exceed 40°C.

### 3.3 Schematics

#### 3.3.1 Dimensions for Standard and High-Vacuum Motors

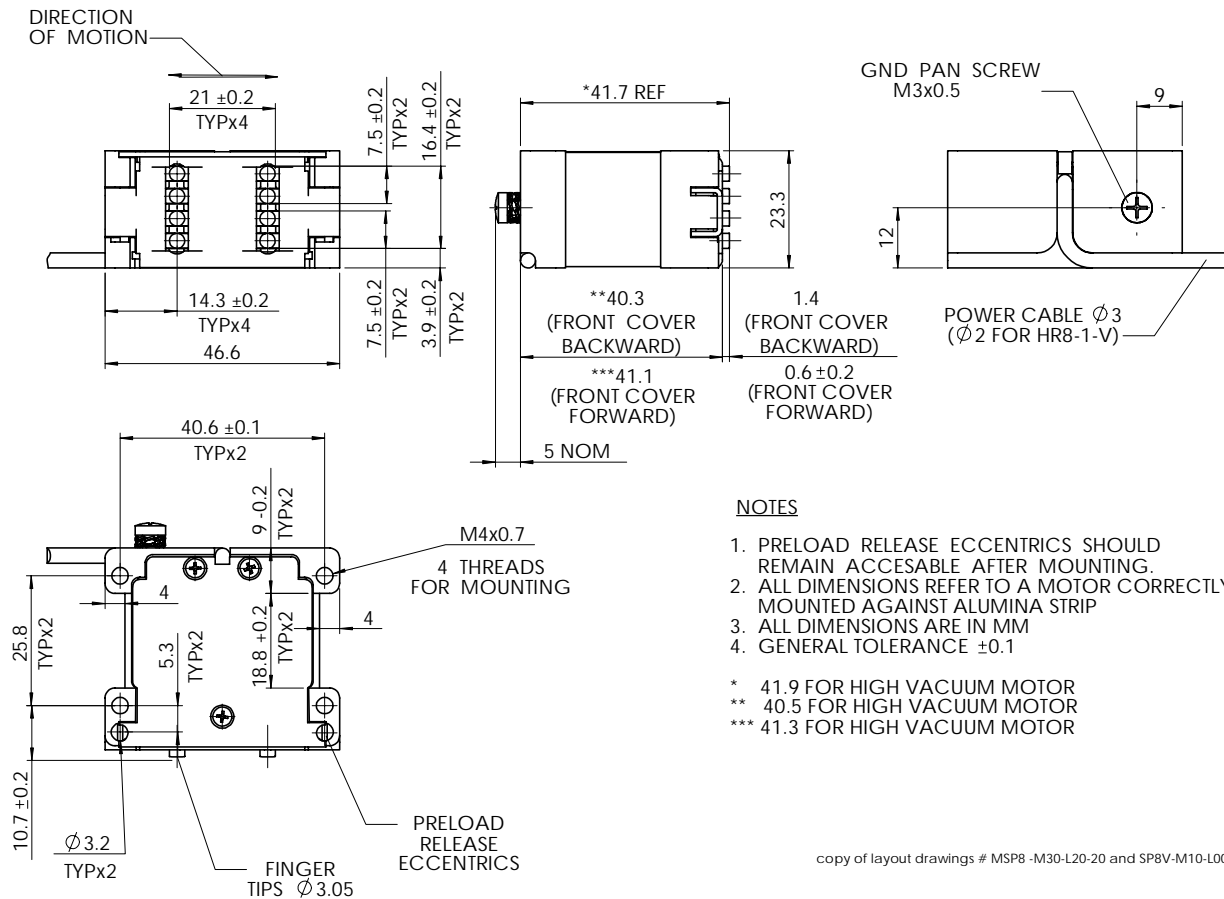

Figure 3-5: Dimensions for Standard and High-Vacuum Motors

### 3.3.2 Dimensions for Ultra-High-Vacuum Motors

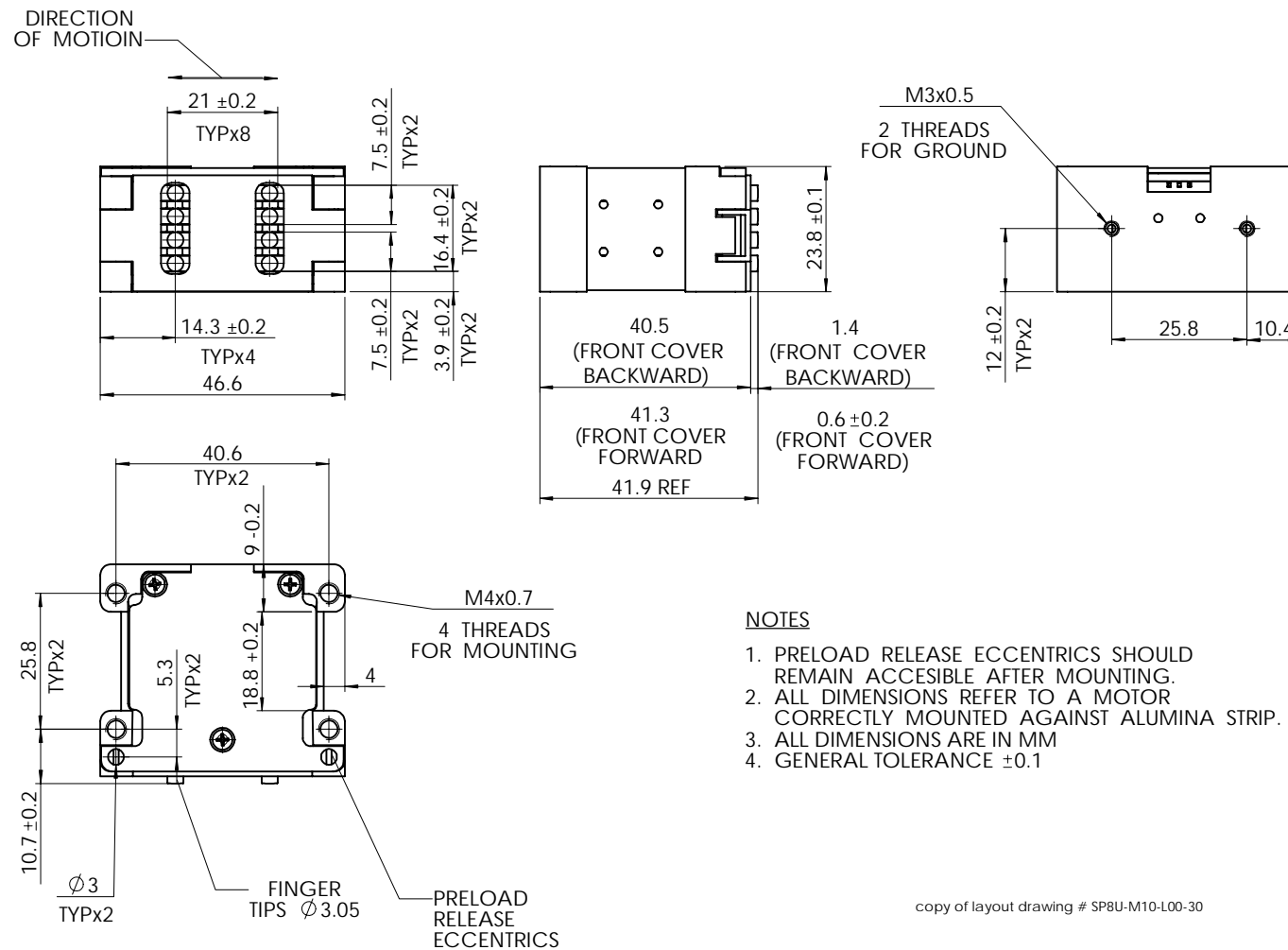

Figure 3-6: Dimensions for Ultra-High-Vacuum Motor

### 3.3.3 Mounting Base Dimensions

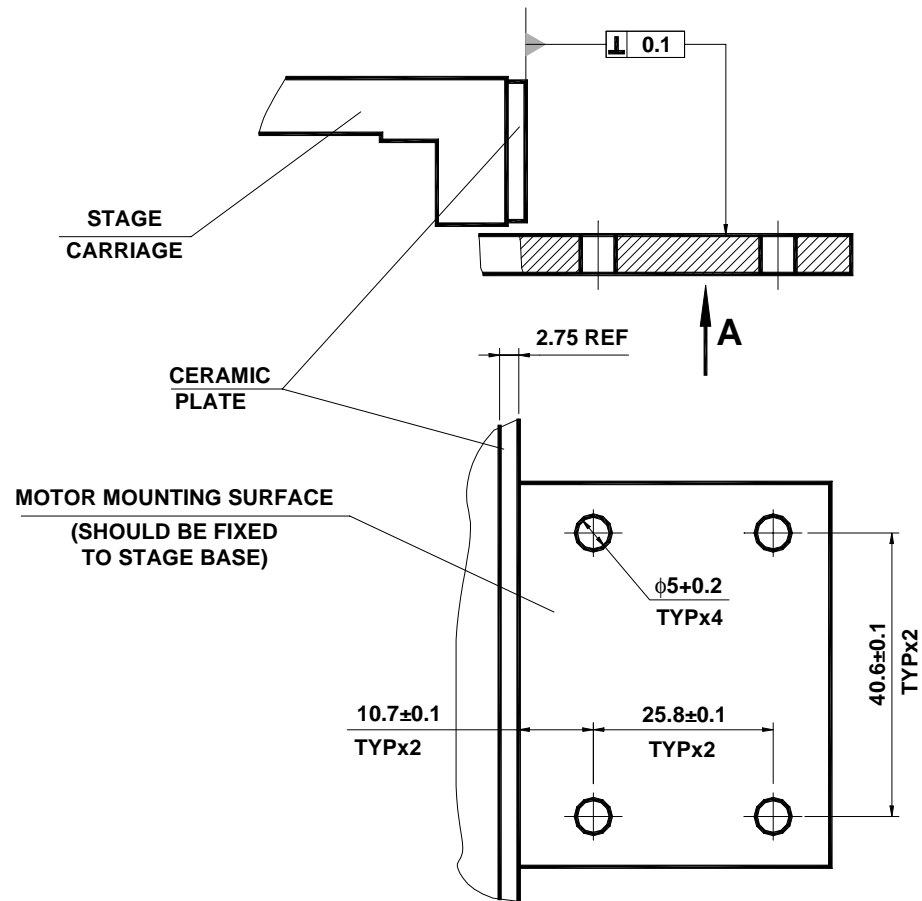

Figure 3-7: Base Layout