

THESE DRAWINGS AND SPECIFICATIONS ARE THE PROPERTY OF MicroE Systems Corp. AND SHALL NOT BE REPRODUCED OR COPIED OR USED AS THE BASIS FOR MANUFACTURE OR SALE OF APPARATUS WITHOUT EXPRESS WRITTEN AUTHORIZATION FROM MicroE Systems Corp.

REVISIONS				
LTR	ECO	DESCRIPTION	DATE	APPROVED
S2	1533	ADDED NOTE 7., UPDATED TABLE 1. "RESERVED" PADS.		
S3	1542	UPDATED TABLE 1. PAD FUNCTIONS.		
A	1577	RELEASE TO PRODUCTION	4/5/06	MF
B	1637	ADD DIM FROM DATUM C TO OPTICAL CENTER.	7/17/06	SB
C	1754	ADDED "CE300" TO DESCRIPTION.	12/21/06	SB
D	1877	UPDATE DWG TO MATCH THE ACTUAL CERAMIC	7/05/07	SB

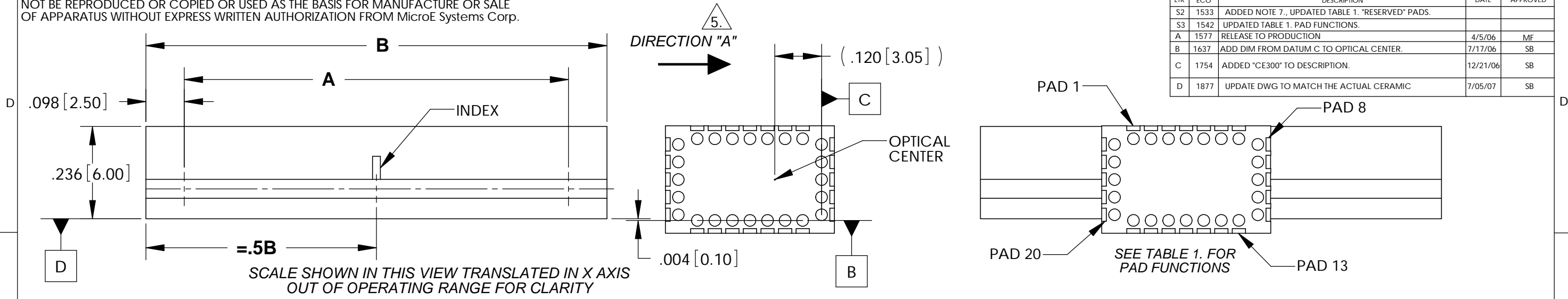

SCALE SHOWN IN THIS VIEW TRANSLATED IN X AXIS OUT OF OPERATING RANGE FOR CLARITY

TABLE 1

Pad	Function	Pad	Function
1	Index Window -	13	AN
2	GND	14	SIN+
3	RESERVED	15	RESERVED
4	RESERVED	16	RESERVED
5	RESERVED	17	RESERVED
6	+5VA	18	GND
7	RESERVED	19	+5VD
8	GND	20	B+
9	DC2	21	B-
10	RESERVED	22	A+
11	DC1	23	A-
12	RESERVED	24	Index Window +

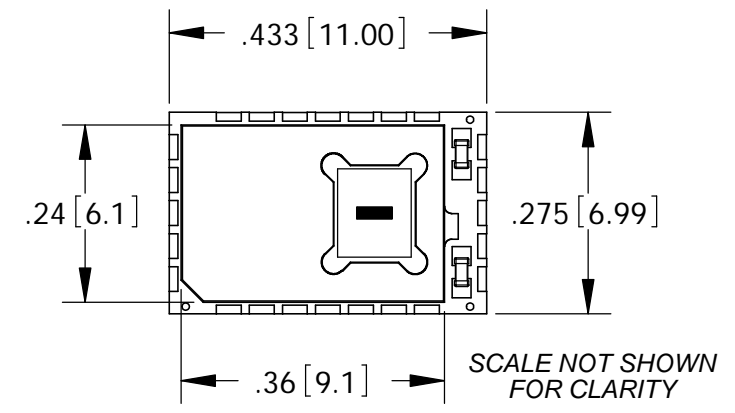
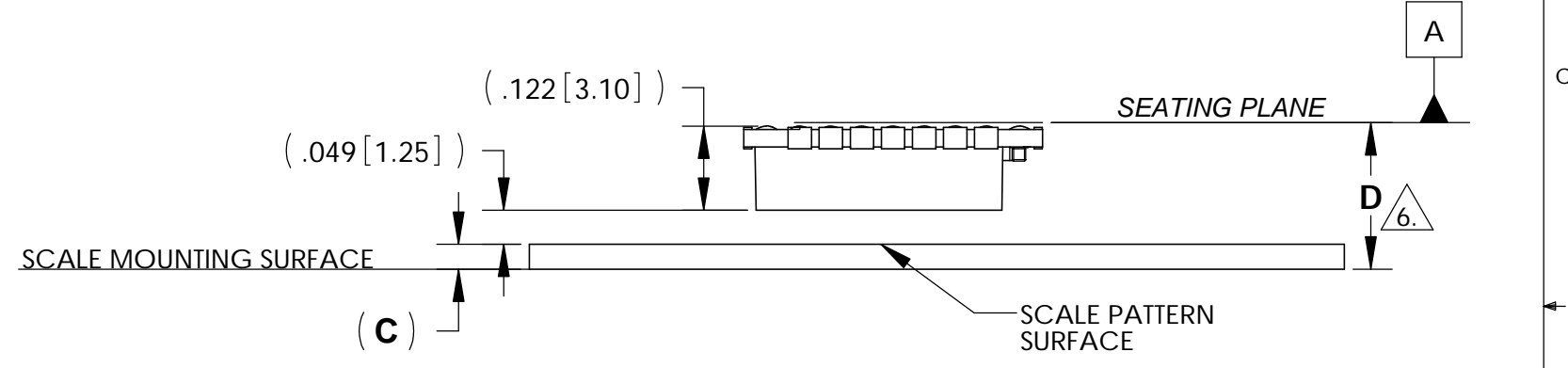
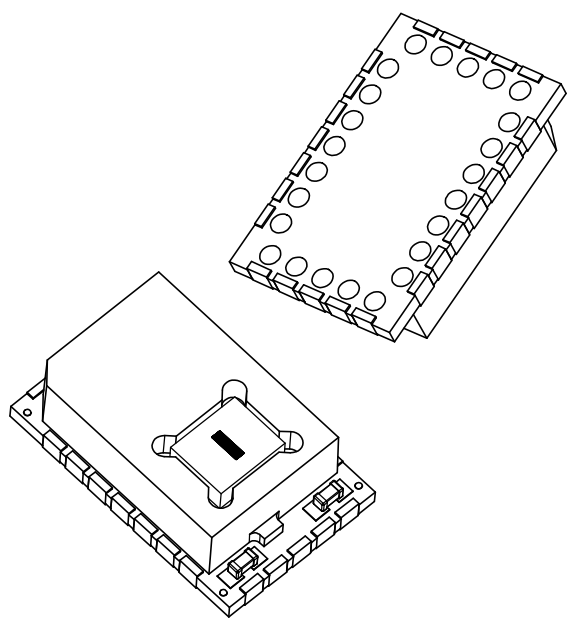

- NOTES:
- IF BENCHING PINS ARE TO BE USED, PINS MUST BE PLACED ALONG DATUM EDGES OF THE SCALE FOR PROPER ALIGNMENT.
  - HEIGHT OF SCALE BENCHING PINS NOT TO EXCEED THE THICKNESS OF THE SCALE.
  - DATUM EDGES [B] AND [C] OF CHIPENCODER ARE THE CENTERLINES OF THE BGA PADS.
  - REFER TO ID-00321 FOR CHIPENCODER MOUNTING REQUIREMENTS.

5. WHEN SCALE MOVES IN DIRECTION "A" WITH RESPECT TO A STATIONARY READHEAD, OUTPUT SIGNAL A+(PAD 22) LEADS OUTPUT SIGNAL B+ (PAD 20).

6. FOR SCALES WITH TAPE (LXXCE-T), THE SCALE MOUNTING SURFACE MUST BE

.006" [.152] FURTHER AWAY FROM THE SEATING PLANE OF CHIPENCODER FOR NOMINAL Z HEIGHT.  
 DIM = .218 [5.54] SCALES UP TO L130CE  
 DIM = .281 [7.14] SCALES FROM L135CE TO L325CE

7. DO NOT CONNECT TO "RESERVED" PADS. SEE TABLE 1. FOR RESERVED PADS.

SCALE IDENTIFICATION AND SIZE

Scale Identification	Dim. A Measured Length	Dim. B Scale Length	Dim. C Scale Thickness	Dim. D Mounting Dim
LXXCE	XXmm-5mm	XXmm	.036±.004 [.91±.10]	.212[5.39]
L30CE	30mm-5mm = 25mm	30mm	L135CE to L325CE	
(max) L325CE	325mm-5mm = 320mm	325mm	.098±.004 [2.50±.10]	.275[6.98]

UNLESS OTHERWISE SPECIFIED ALL DIMENSIONS ARE IN INCHES (MILLIMETERS) DIM. APPLY AFTER PROCESSING INTERPRET ALL GEOMETRIC TOLS. PER ANSI Y14.5M-1994

TOLERANCES ARE:  
 DECIMALS: .XX [.X] ± .01 [.25]  
 .XXX [.XX] ± .005 [.13]  
 ANGULAR: ±30 MIN.

APPROVALS	DATE
DRAWN: S. BUTURLIA	12/8/05
CHECKED:	
ENGRG.: VINCE CLARK	4/4/06
MFG ENG: THOMAS GARCIA	4/6/06
QA: S. OPPENHEIM	4/4/06

UNITS: INCHES [MM]

**GSI** **MicroE Systems**  
 Division of GSI

8 Erie Drive  
 Natick, MA 01760

DESCRIPTION:  
**INTERFACE, ENCODER,  
 40um SHORT LINEAR,  
 CHIPENCODER CE300**

SIZE: B DWG. NO.: ID-00327 REV. D  
 SCALE: 1:1 CAD FILE: SHEET 1 OF 1

THESE DRAWINGS AND SPECIFICATIONS ARE THE PROPERTY OF MicroE Systems Corp. AND SHALL NOT BE REPRODUCED OR COPIED OR USED AS THE BASIS FOR MANUFACTURE OR SALE OF APPARATUS WITHOUT EXPRESS WRITTEN AUTHORIZATION FROM MicroE Systems Corp.

		REVISIONS		
LTR	ECO	DESCRIPTION	DATE	APPROVED
S2	1533	ADDED NOTE 7. UPDATED TABLE 1. "RESERVED" PADS.		
S3	1542	UPDATED TABLE 1. PAD FUNCTIONS.		
A	1604	RELEASE TO PRODUCTION	5/18/06	MF
B	1637	ADDED DIM FROM DATUM C TO OPTICAL CENTER.	7/17/06	SB
C	1754	ADDED "CE300" TO DESCRIPTION.	12/21/06	SB
D	1877	UPDATE DWG TO REFLECT ACTUAL CERAMIC	07/05/07	SB

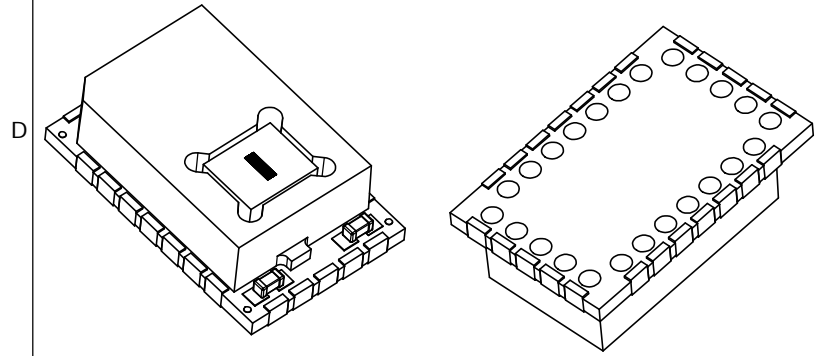

MOUNTING HOLE AND THREAD F. EQ. SPACED ON A BOLT CIRCLE ØH

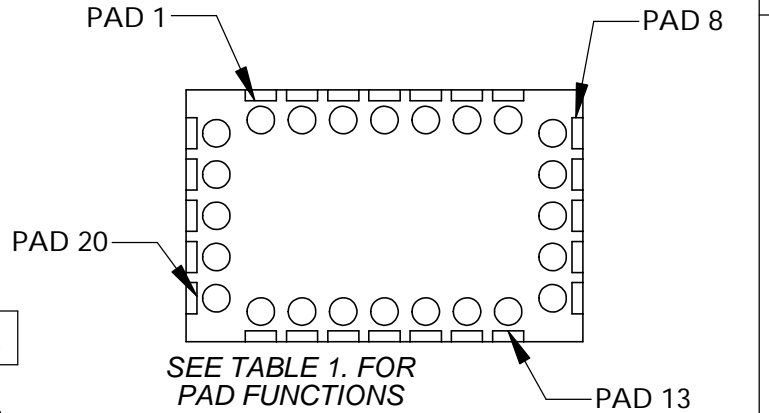
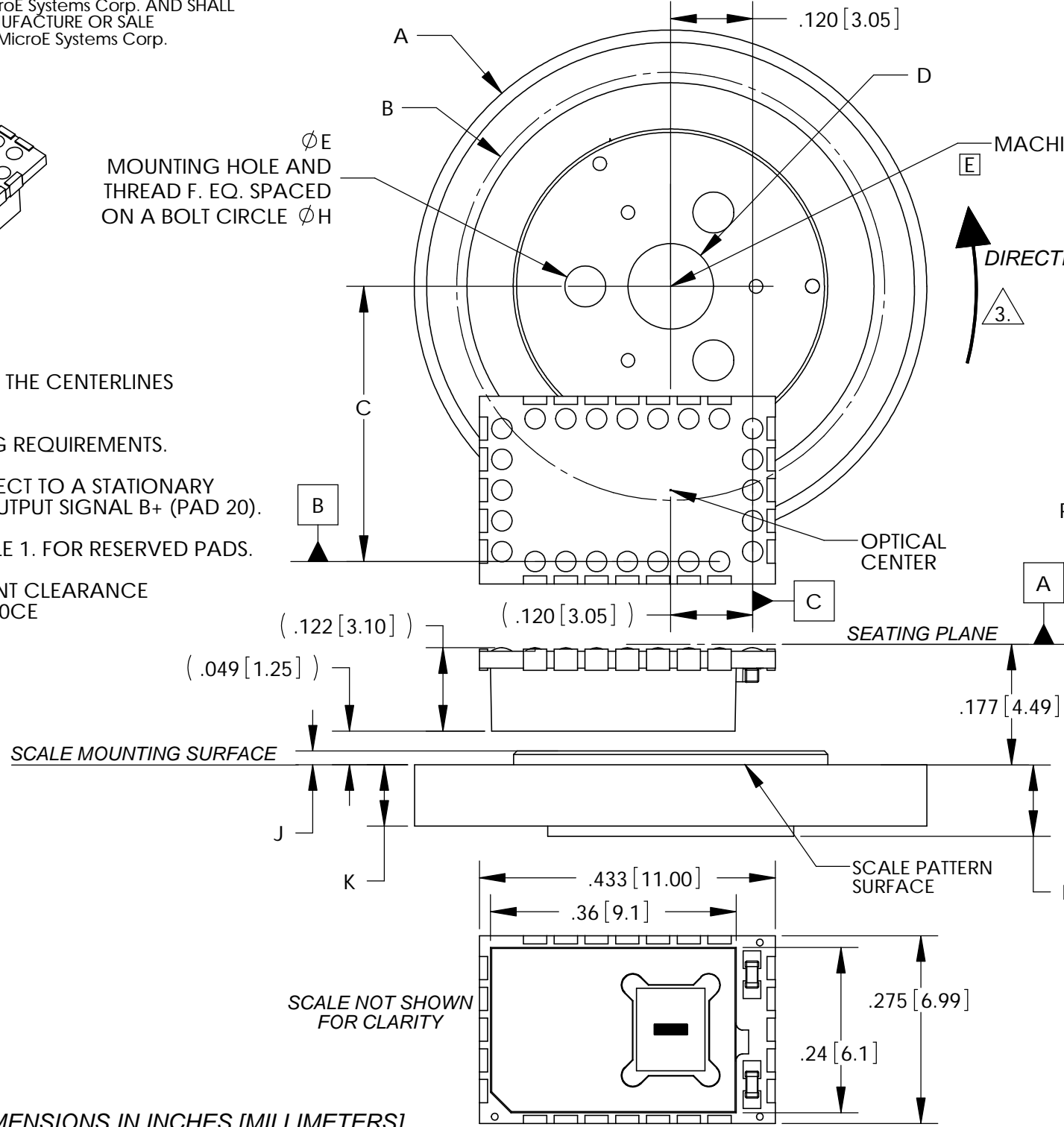

- NOTES:
- DATUM EDGES [B] AND [C] OF CHIPENCODER ARE THE CENTERLINES OF THE BGA PADS.
  - REFER TO ID-00321 FOR CHIPENCODER MOUNTING REQUIREMENTS.
  - WHEN SCALE MOVES IN DIRECTION "A" WITH RESPECT TO A STATIONARY READHEAD, OUTPUT SIGNAL A+ (PAD 22) LEADS OUTPUT SIGNAL B+ (PAD 20).
  - DO NOT CONNECT TO "RESERVED" PADS. SEE TABLE 1. FOR RESERVED PADS.
- \* SOME HUBS INCLUDE RELIEF TO PROVIDE SUFFICIENT CLEARANCE NOT SHOWN IN THESE VIEWS. SCALE SHOWN R1910CE

TABLE 1.

Pad	Function	Pad	Function
1	Index Window -	13	AN
2	GND	14	SIN+
3	RESERVED	15	RESERVED
4	RESERVED	16	RESERVED
5	RESERVED	17	RESERVED
6	+5VA	18	GND
7	RESERVED	19	+5VD
8	GND	20	B+
9	DC2	21	B-
10	RESERVED	22	A+
11	DC1	23	A-
12	RESERVED	24	Index Window +

SCALE IDENTIFICATION AND SIZE. DIMENSIONS IN INCHES [MILLIMETERS]

Scale Identification	Counts/ Rev	Dim. A Scale O.D.	Dim. A Scale I.D.	Dim. B Optical Dia.	Dim. C Mounting Dim.	Dim. D Hub I.D.	Dim. E Mounting Hole Dia.	Thread F.	Dim. J * Hub Height	Dim. K Scale Thickness	Dim. L Hub Relief
R1206CE	825	0.472 [12.00]	.250+/-0.005 [6.35+/-0.13]	0.414 [10.50]	0.296+/-0.002 [7.52+/-0.05]	0.1253+0.0005/-0.0000 [3.182+0.13/-0.000]	N/A	N/A	0.040 [1.02]	0.036+/-0.004 [0.91+/-0.10]	0.045 [1.14]
R1506CE	1,024	0.572 [14.53]	.250+/-0.005 [6.35+/-0.13]	0.513 [13.04]	0.346+/-0.002 [8.79+/-0.05]	0.1253+0.0005/-0.0000 [3.182+0.13/-0.000]	N/A	N/A	0.040 [1.02]	0.036+/-0.004 [0.91+/-0.10]	0.045 [1.14]
R1910CE	1,250	0.750 [19.05]	.375+/-0.005 [9.53+/-0.13]	0.627 [15.92]	0.403+/-0.002 [10.23+/-0.05]	0.1253+0.0005/-0.0000 [3.182+0.13/-0.000]	0.047 [1.19]	0-80	0.040 [1.02]	0.090+/-0.004 [2.29+/-0.10]	0.105 [2.67]
R3213CE	2,048	1.250 [31.75]	.500+/-0.005 [12.70+/-0.13]	1.027 [26.08]	0.603+/-0.002 [15.31+/-0.05]	0.2503+0.0005/-0.0000 [6.357+0.13/-0.000]	0.070 [1.78]	2-56	0.050 [1.27]	0.090+/-0.004 [2.29+/-0.10]	0.105 [2.67]
R5725CE	4,096	2.250 [57.15]	1.000+/-0.005 [25.40+/-0.13]	2.053 [52.15]	1.116+/-0.002 [28.35+/-0.05]	0.5003+0.0005/-0.0000 [12.707+0.13/-0.000]	0.136 [3.45]	8-32	0.060 [1.52]	0.090+/-0.004 [2.29+/-0.10]	0.105 [2.67]
R10851CE	8,192	4.250 [107.95]	2.000+/-0.005 [50.80+/-0.13]	4.106 [104.30]	2.143+/-0.002 [54.42+/-0.05]	1.0003+0.0005/-0.0000 [25.408+0.13/-0.000]	0.136 [3.45]	8-32	0.080 [2.03]	0.090+/-0.004 [2.29+/-0.10]	0.105 [2.67]

UNLESS OTHERWISE SPECIFIED ALL DIMENSIONS ARE IN INCHES DIM. APPLY AFTER PROCESSING INTERPRET ALL GEOMETRIC TOLS. PER ANSI Y14.5M-1994

TOLERANCES ARE:  
 DECIMALS: .XX [X]±0.1 [25]  
 .XXX [XX]±0.005 [13]

ANGULAR: ±30 MIN.

APPROVALS	DATE
DRAWN: S.BUTURLIA	12/8/05
CHECKED:	
ENGR. VINCE CLARK	5/18/06
MFG ENG L. SALATE	5/18/06
QA A. VILLARROEL	5/18/06

UNITS: INCHES [mm]

**GSI** MicroE Systems Division of GSI

8 Erie Drive  
Natick, MA 01760

DESCRIPTION: INTERFACE, ENCODER, 40um ROTARY w/HUB, CHIPENCODER CE300

SIZE DWG. NO. ID-00329 REV. D

SCALE: 1:1 CAD FILE: SHEET 1 OF 1

THESE DRAWINGS AND SPECIFICATIONS ARE THE PROPERTY OF MicroE Systems Corp. AND SHALL NOT BE REPRODUCED OR COPIED OR USED AS THE BASIS FOR MANUFACTURE OR SALE OF APPARATUS WITHOUT EXPRESS WRITTEN AUTHORIZATION FROM MicroE Systems Corp.

REVISIONS				
LTR	ECO	DESCRIPTION	DATE	APP'D
S2	1513	ADDED NOTES 3 AND 4.	11/30/05	SB
S3	1542	PINS 4, 5, 7, 10, 12, 15, 16, & 17 CHANGED TO NC.	1/25/06	SB
A	1582	PINS 3 CHANGED TO NC. RELEASE TO PRODUCTION	4/17/06	SB
B	1643	ADDED C5 CAPACITOR. SEE ECO.	8/2/06	SB
C	1688	NOTE 4, "HAND SOLDERING" WAS "REWORK".	9/28/06	SB
D	1754	ADDED "CE300" TO DESCRIPTION.	12/21/06	SB
E	1766	CORRECTED DIMENSIONS. SEE ECO.	1/23/07	SB
F	1885	ADDED D1, R2 AND NOTE 5. SEE ECO.	7/11/07	DS

**Electrical Interface:**

The ChipEncoder CE300 must be interfaced to subsequent electronics in the following manner to ensure proper system performance. All passive components must be located directly adjacent to the pads to which they are connected.

DESIGNATION	DESCRIPTION	MFG P/N OR EQUIVALENT
C1, C2	Capacitor, Ceramic, 0.1uF, 10V, ±10%, 0402	Panasonic ECJ-0EB1A104K
C3, C4, C5	Capacitor, Ceramic, 1.0uF, 10V, ±10%, 0603	Panasonic ECJ-1VB1A105K
L1	EMI Filter, 600 ohms @ 100Mhz, 200mA, 0603	Murata BLM18AG601SN1D
R1	Resistor, Film, 1.00K, 1/16W, 1%, 0402	Panasonic ERJ-2RKF1001X
R2	Resistor, Film, 121 ohms, 1/16W, 1%, 0402	Panasonic ERJ-2RKF1210X
D1	Diode, ESD Protection TVS 3.3V	ON Semiconductor ESD9x3.3ST5G

5.

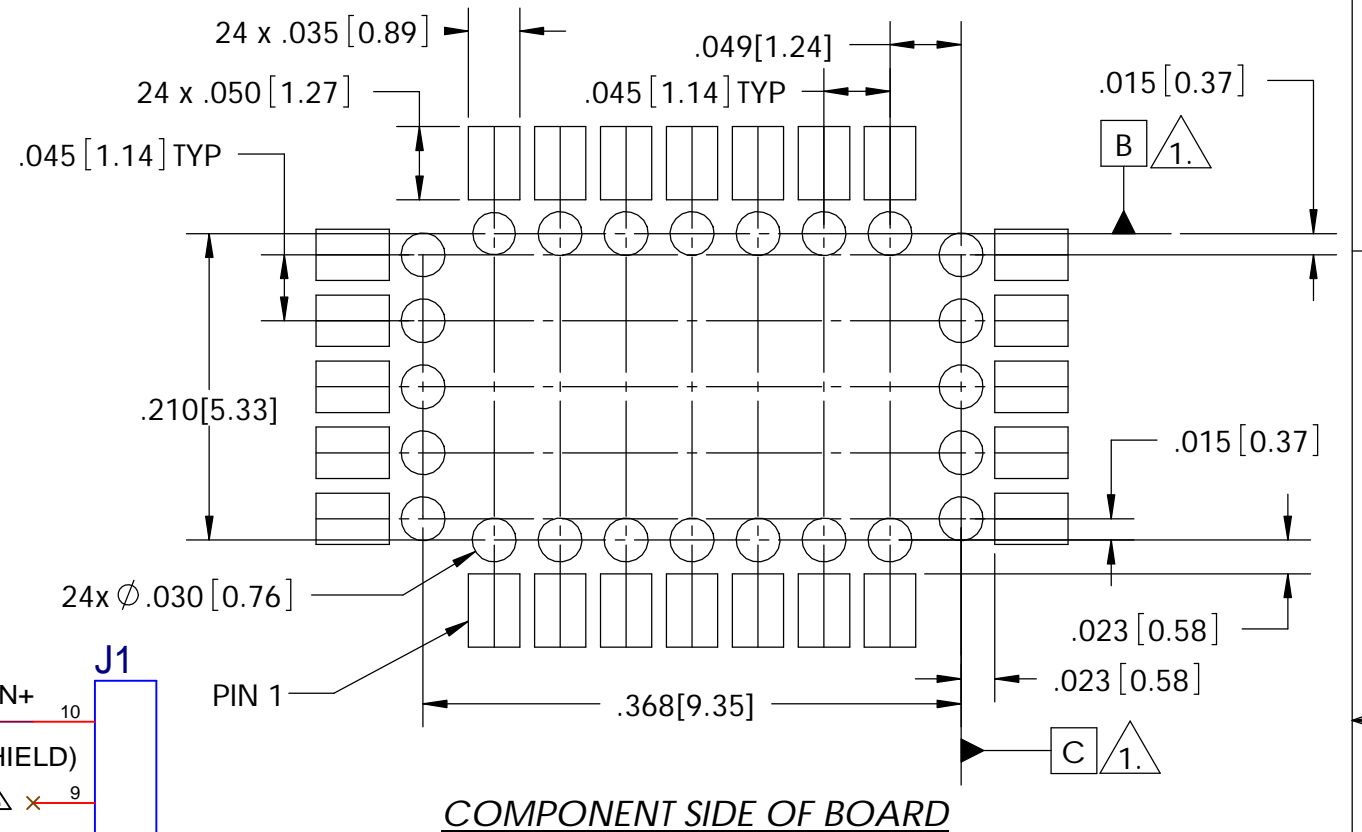

**COMPONENT SIDE OF BOARD**

**NOTES:**

1. THE DATUMS SHOWN REPRESENT THE PAD CENTERS ON THE 7mm x 11mm CHIPENCODER.
2. GROUND AT RECEIVER.
3. BGA SOLDER BALL COMPOSITION IS Sn96.5 Ag3.0 Cu0.5 (SAC305)
4. DEVICE SUPPORTS DUAL SMT FOOTPRINT. PRIMARY LAYOUT IS BGA. SECONDARY LAYOUT IS EDGE CASTELLATIONS, FOR HAND SOLDERING IF REQUIRED.
5. OPTIONAL PROTECTION DEVICES (R2 & D1) FOR HIGH ESD ENVIRONMENTS. REPLACE R2 WITH A SHORT IF NOT USED.

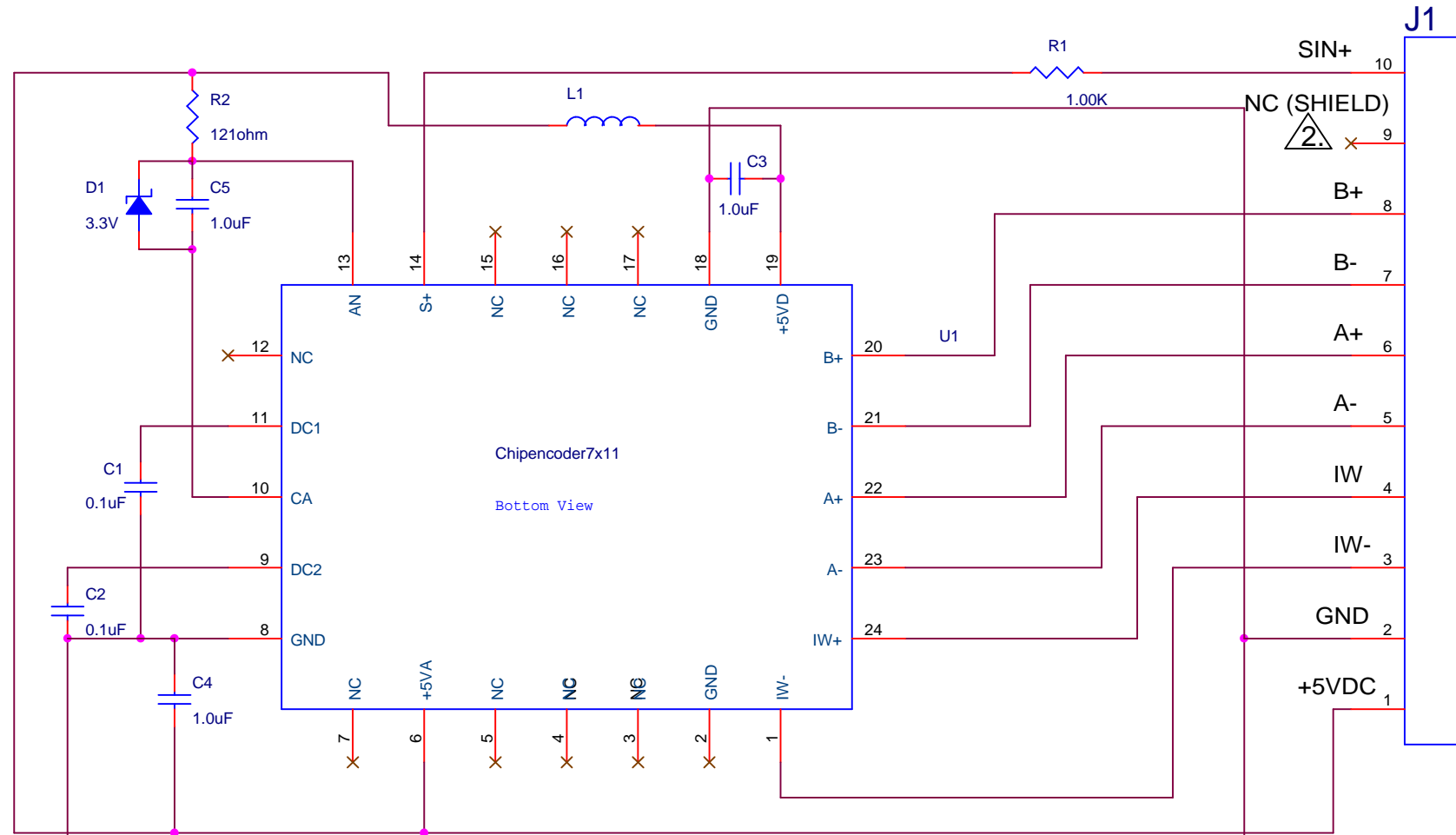

UNLESS OTHERWISE SPECIFIED ALL DIMENSIONS ARE IN INCHES[millimeters] DIM. APPLY AFTER PROCESSING INTERPRET ALL GEOMETRIC TOLS. PER ANSI Y14.5M-1994 TOLERANCES ARE: DECIMALS: .XX[X] ±.01[.25] .XXX[.XX] ±.005[.13] SURFACE FINISH $\sqrt{32}$ BREAK SHARP EDGES, REMOVE BURRS	APPROVALS DRAWN M. FARLAND CHECKED VINCE CLARK ENGRG. NJ TOBEY MFG ENG THOMAS GARCIA QA JOHN DALCO	DATE 9/13/05 4/7/06 4/17/06 4/7/06 4/7/06	MicroE Systems Division of GSI 8 Erie Drive Natick, MA 01760 DESCRIPTION: <b>LAND PATTERN &amp; ELECTRICAL          INTERFACE REQUIREMENTS,          CHIPENCODER, CE300, 40um</b>	
	MATERIAL:	FINISH:		MAKE FROM:
	SIZE B	DWG. NO. ID-00321		REV. F
	SCALE: 1:2	CAD FILE:		3RD ANGLE PROJECTION

THESE DRAWINGS AND SPECIFICATIONS ARE THE PROPERTY OF MicroE Systems Corp. AND SHALL NOT BE REPRODUCED OR COPIED OR USED AS THE BASIS FOR MANUFACTURE OR SALE OF APPARATUS WITHOUT EXPRESS WRITTEN AUTHORIZATION FROM MicroE Systems Corp.

REVISIONS				
LTR	ECO	DESCRIPTION	DATE	CHKR-APVD
S1		INITIAL	12/21/06	SB
A	1779	RELEASE TO PRODUCTION	03/07/07	SB
B	1877	UPDATAE DWG TO REFLECT ACTUAL CERAMIC	07/05/07	SB

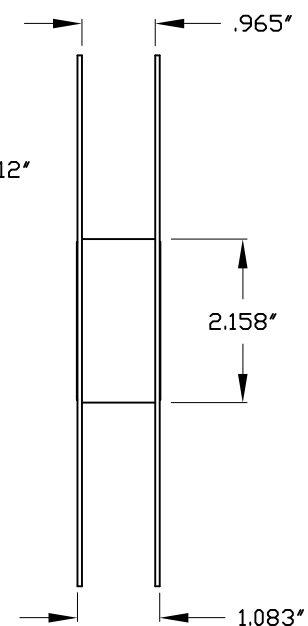
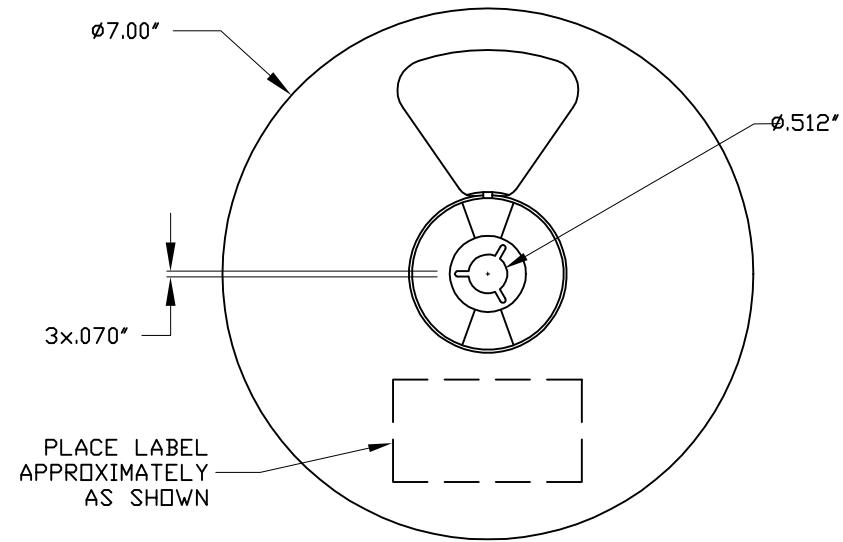
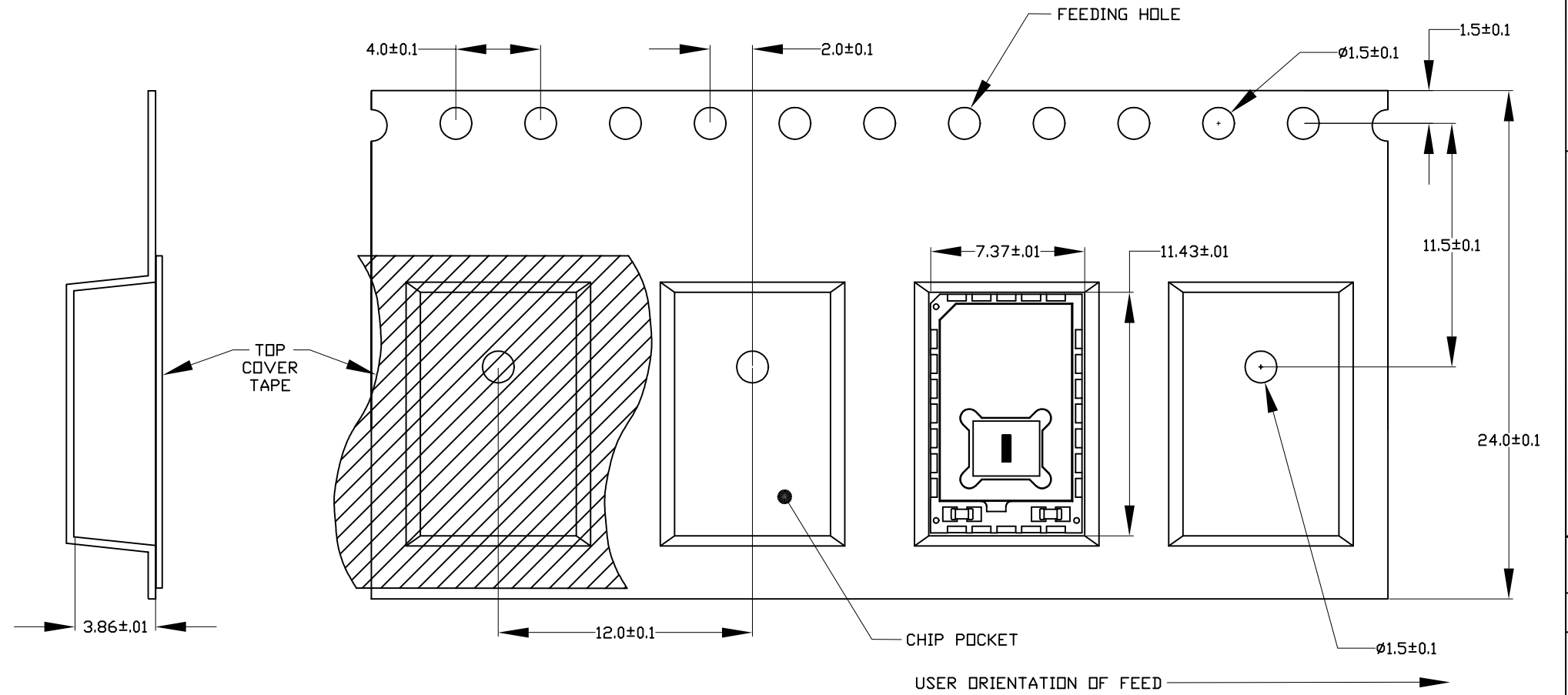
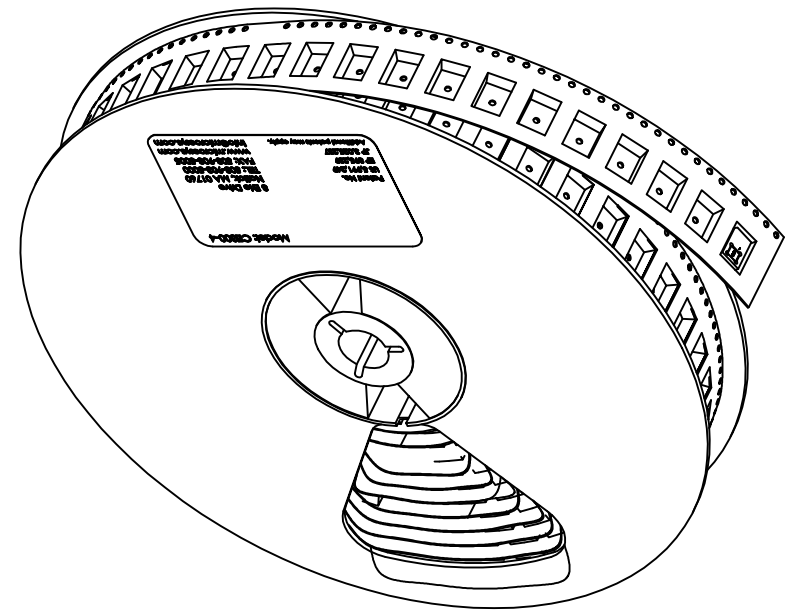

<p>UNLESS OTHERWISE SPECIFIED: ALL DIMENSIONS ARE IN MILLIMETERS DIM. APPLY AFTER PROCESSING</p> <p>INTERPRET ALL GEOMETRIC TOLS. PER ANSI Y14.5M-1994</p> <p>TOLERANCES ARE: DECIMALS: .X ±.3 .X ±.13 SURFACE FINISH 32 BREAK SHARP EDGES, REMOVE BURRS</p>	<p>DRAWN M. FARLAND</p>	<p>DATE 12/12/06</p>	<p>DESCRIPTION: INTERFACE, PACKAGING, TAPE &amp; REEL, CE300, ENCODER SIDE UP</p>		
	<p>CHECKED</p>	<p>ENGRG. VINCE CLARK</p>		<p>03/07/07</p>	
	<p>MFG. TOM GARCIA</p>	<p>03/07/07</p>		<p>QA. JOHN DALCO</p>	<p>03/07/07</p>
	<p>ADDITIONAL</p>	<p>MAKE FROM:</p>		<p>SCALE:</p>	
<p>MATERIAL:</p>	<p>FINISH:</p>	<p>SIZE B</p>	<p>DWG No. ID-00341</p>	<p>REV. B</p>	
<p>3rd ANGLE PROJECTION</p>			<p>SHEET: 1 OF 1</p>		

THESE DRAWINGS AND SPECIFICATIONS ARE THE PROPERTY OF MicroE Systems Corp. AND SHALL NOT BE REPRODUCED OR COPIED OR USED AS THE BASIS FOR MANUFACTURE OR SALE OF APPARATUS WITHOUT EXPRESS WRITTEN AUTHORIZATION FROM MicroE Systems Corp.

REVISIONS

REV.	ECO	DESCRIPTION	DATE	APP'D
S2	1674	PAD 12 WAS LABELED INCORRECTLY AS PAD 15.	9/8/06	SB
S3	1681	ADDED DATUM B & C DIMENSIONS.	9/22/06	SB
A	1875	RELEASE TO PRODUCTION	7/05/07	SB
B	1925	VARIOUS CHANGES. SEE ECO.	11/2/07	SB

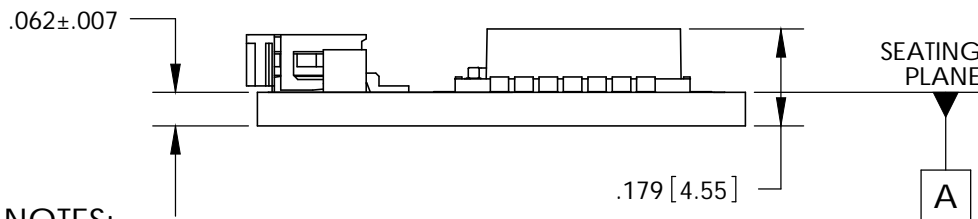
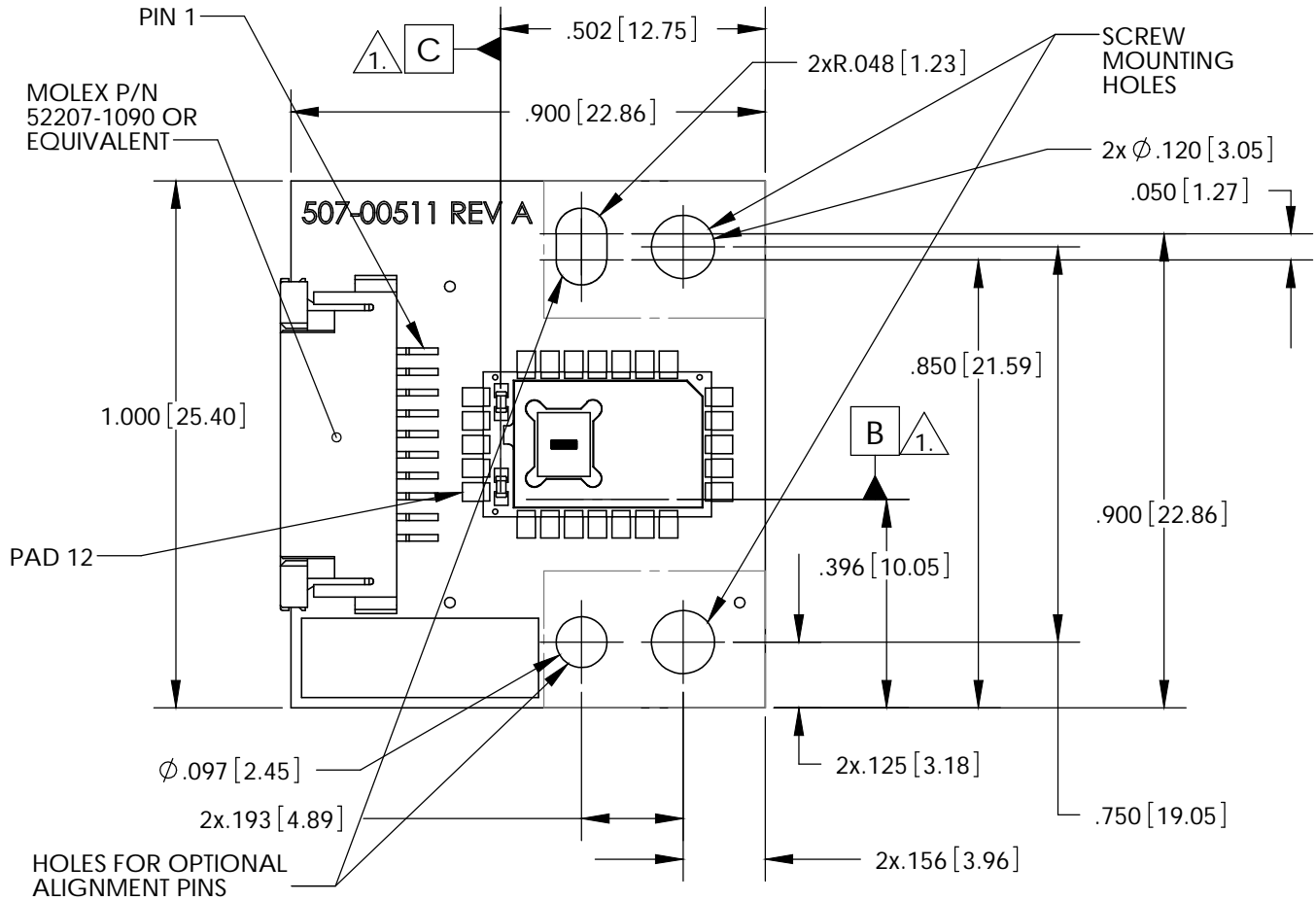

NOTES:

1. DATUMS B & C ARE CENTERLINES OF PADS. REFERENCE DWG ID-00321.

10 PIN ZIF CONNECTOR PINOUTS	
1	+5V
2	GND
3	IW-
4	IW+
5	A-
6	A+
7	B-
8	B+
9	NC
10	SIN+

UNLESS OTHERWISE SPECIFIED:  
ALL DIMS ARE IN INCHES.  
DIMS. APPLY AFTER PROCESSING.

TOLERANCES:  
DECIMALS: .XX ±.01  
ANGULAR: ±30 MIN  
.XXX ±.005

SURFACE FINISH: 32

BREAK SHARP EDGES

FINISH:

APPROVALS		DATE
DRAWN	M. FARLAND	4/10/06
CHECKED	VINCE CLARK	4/10/06
ENGR.	VINCE CLARK	7/05/07
MFG	T. GARCIA	7/05/07
QA	J. DALCO	7/05/07
MATERIAL:		



**MicroE Systems**  
Division of GSI  
8 ERIE DRIVE  
NATICK, MA 01760

DESCRIPTION: <b>INTERFACE, EVALUATION PC BOARD, CHIPENCODER CE300</b>		
SIZE	DWG. NO.	REV.
<b>A</b>	<b>ID-00332</b>	<b>B</b>

SCALE: 3:1      3rd ANGLE PROJECTION      SHEET: 1 OF 1