

---

# PSS User Guide

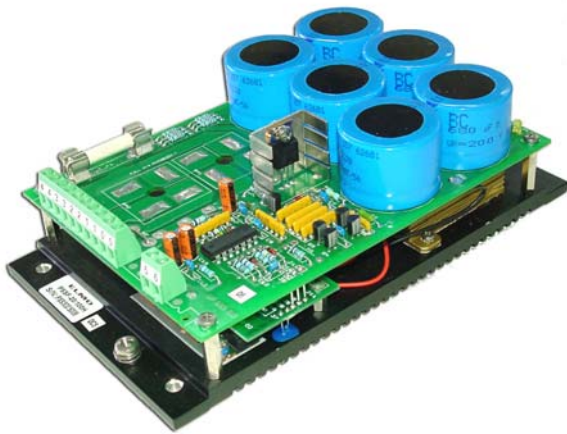

**PSS 3U**



**PSS 6U**

March 2005

---

## Important Notice

This guide is delivered subject to the following conditions and restrictions:

- This guide contains proprietary information belonging to Elmo Motion Control Ltd. Such information is supplied solely for the purpose of assisting users of the PSS and PSSF series of power supplies.
- The text and graphics included in this manual are for the purpose of illustration and reference only. The specifications on which they are based are subject to change without notice.
- Information in this document is subject to change without notice.

Doc. No. MAN-PSSUG  
Copyright © 2003~2005  
Elmo Motion Control  
All rights reserved

<b>Product Catalog No:</b>	<b>PSS F - 20 / 200 R</b>
	Power Supply ———┐ Shunt Regulator ———┐ Fan Cooling Required ———┐ Rated Current ———┐ Mounting: R = Rack H = Horizontal Panel Output Voltage

### Revision History:

Ver. 3.01	March 2005	Non-Isolated AC Supplies eliminated (MAN-PSSUG.PDF)
Ver. 3.0	April 2003	(PSSUG0403.PDF)
Ver. 2.0	January 1998	
Ver. 1.0	October 1993	Initial Release

---

**Elmo Motion Control Inc.**  
1 Park Drive, Suite 12  
Westford, MA 01886  
USA  
Tel: +1 (978) 399-0034  
Fax: +1 (978) 399-0035  
[info-us@elmomc.com](mailto:info-us@elmomc.com)

**Elmo Motion Control GmbH**  
Steinbeisstrasse 41  
D-78056, Villingen-Schwenningen  
Germany  
Tel: +49 (07720) 8577-60  
Fax: +49 (07720) 8577-70  
[info-de@elmomc.com](mailto:info-de@elmomc.com)

  
Motion Control  
[www.elmomc.com](http://www.elmomc.com)



# Contents

<b>Chapter 1: Safety Information</b> .....	<b>1-1</b>
1.1 Warnings.....	1-1
1.2 Cautions.....	1-2
1.3 Warranty Information.....	1-2
<b>Chapter 2: Product Description</b> .....	<b>2-1</b>
2.1 Standard Features.....	2-1
2.2 Fault Protection.....	2-2
2.3 Block Diagram.....	2-3
2.4 Technical Specifications.....	2-3
2.4.1 PSS Power Supplies with Shunt Regulators.....	2-3
2.4.2 Shunt Regulator Specifications.....	2-3
2.5 Dimensional Drawings.....	2-4
2.5.1 PS1 (for PSSF-20/100 and PSSF-20/200).....	2-5
2.5.2 PS2 (for PSS-15/100 and PSS-12/200).....	2-6
2.5.3 PS3 (for PSS-30/200 and PSSF-60/200*).....	2-7
2.5.4 Rack Mount.....	2-8
<b>Chapter 3: Installation</b> .....	<b>3-1</b>
3.1 Unpacking the System Components.....	3-1
3.2 Mounting and Wiring the PSS.....	3-1
3.2.1 Wiring Guidelines.....	3-1
3.2.2 AC Power Supplies.....	3-1
3.2.3 Wiring Diagrams.....	3-2
3.3 Startup Procedures.....	3-3
3.3.1 Switching from Single-phase to Three-phase (3U only).....	3-3
3.3.2 Capacitor Reforming.....	3-4
3.3.3 LED Diagnostics.....	3-4



# Chapter 1: Safety Information

In order to achieve the optimum, safe operation of the PSS power supply, it is imperative that you implement the safety procedures included in this user guide. This information is provided to protect you and to keep your work area safe when operating the PSS and accompanying equipment. Read this chapter carefully before you begin the installation process.

Only qualified personnel may install, adjust, maintain and repair the power supply. A “qualified person” has the knowledge and authorization to perform tasks such as transporting, assembling, installing, commissioning and operating motors.

The PSS power supply contains electrostatic-sensitive components that can be damaged if handled incorrectly. To prevent any electrostatic damage, avoid contact with highly insulating materials, such as plastic film and synthetic fabrics. Place the product on a conductive surface and ground yourself in order to discharge any possible static electricity build-up.

To avoid any potential hazards that may cause severe personal injury or damage to the product during operation, keep all covers and cabinet doors shut.

The following safety symbols are used in this manual:



**Warning:**

This information is needed to avoid a safety hazard, which might cause bodily injury.



**Caution:**

This information is necessary for preventing damage to the product or to other equipment.



**Note:**

This is auxiliary information that ensures the correct operation of the equipment.

## 1.1 Warnings

	To avoid electric arcing and hazards to personnel and electrical contacts, never connect/disconnect the power supply while the power source is on.
	Power cables can carry a high voltage, even when the motor is not in motion. Disconnect the PSS from all voltage sources before it is disassembled for servicing.
	After shutting off the power and removing the power source from your equipment, wait at least 5 minutes before touching or disconnecting parts of the equipment that are normally loaded with electrical charges (such as capacitors or contacts). Measuring the electrical contact points with a meter before touching the equipment is recommended.

## 1.2 Cautions



The PSS contains hot surfaces and electrically-charged components during operation.



The maximum AC power supply connected to the instrument must comply with the parameters outlined in this guide.

## 1.3 Warranty Information

The products covered in this manual are warranted to be free of defects in material and workmanship and conform to the specifications stated either within this document or in the product catalog description. All Elmo products are warranted for a period of 12 months from the time of installation, or 18 months from time of shipment, whichever comes first. No other warranties, expressed or implied – and including a warranty of merchantability and fitness for a particular purpose – extend beyond this warranty.

## Chapter 2: Product Description

The PSS and PSSF power supplies were designed to complement Elmo servo amplifiers that do not include an integrated power supply. All PSS/PSSF models include shunt regulators and feature high capacitance, a low profile and snap-in capacitors. The PSSF supply requires fan cooling. The power supplies are built around two basic sizes: Eurocard (3U) and double Eurocard (6U). Two mounting versions are available:

- Surface mount version - has 4 thru-holes for screw assembly
- Panel mount version - connects to 19-inch rack with drop-on slots and connects electrically via DIN 41612 backplane connectors

All Eurocard (3U) power supplies are shipped for single-phase connections, although they include a built-in three-phase option. The shunt regulator, included with the PSS and PSSF supply, is designed for use with high-inertia loads. These supplies incorporate thermal and duty-cycle protections.

### 2.1 Standard Features

The following tables list the features of the PSS, in both Horizontal and Rack mount version. Table 2-1 covers the Eurocard (3U) and Table 2-1 covers the double Eurocard (6U) sizes.

Term. Block	32-pin connector	Function	Comment
0	14a, 14c 16a, 16c	AC-1 supply input (through an isolated/floating transformer)	In single-phase connections (of PSS type 3U), this terminal is internally shorted to terminal 1 by W2. The power supply is modified for three-phase connections by removing W2 and connecting the third phase to terminal 1.
1	18a, 18c 20a, 20c	AC-3 supply input (through an isolated/floating transformer)	For DIN mounting, all four pins must be connected.
2	22a, 22c 24a, 24c	DC Power output return (PR)	For DIN mounting, all four pins must be connected.
3	26a, 26c 28a, 28c	DC Positive power output (VP+)	For DIN mounting, all four pins must be connected.
4	30a, 30c 32a, 32c	AC-2 supply input (through an isolated/floating transformer)	For DIN mounting, all four pins must be connected.
5*	6a, 4c	Inhibit indication return	Internally connected to power output common.
6*	4a	Inhibit indication output	Whenever power supply is inhibited (e.g. during thermal/duty cycle), this open collector output goes into low state (maximum sink current: 10 mA, 30 VDC).

Table 2-1: PSS Terminal Description: 3U Power Supplies

Term. Block	32-pin connector	Function	Comment
1	12 - 22 (J2)	Power output return (PR)	For DIN mounting, all six pins must be connected.
2	24 - 32 (J1)	AC-1 supply input (through an isolated/floating transformer)	For DIN mounting, all five pins must be connected.
3	14 - 22 (J1)	AC-2 supply input (through an isolated/floating transformer)	For DIN mounting, all five pins must be connected.
4	4 - 12 (J1)	AC-3 supply input (through an isolated/floating transformer)	For DIN mounting, all five pins must be connected.
5	24 - 32 (J2)	Positive power output (VP+)	For DIN mounting, all five pins must be connected.
6*	4 (J2)	Inhibit indication output	Whenever power supply is inhibited (e.g. during thermal/duty cycle), this open collector output goes into low state (maximum sink current: 10 mA, 30 VDC).
7**	8 (J2)	Fan supply	24 VDC/0.5 A output for an external brushless fan. Common is available in terminal 1

Table 2-2: PSS Terminal Description: 6U Power Supplies

\* Inhibit indication return is available in terminal 1.

\*\* Available for 60A types only.

## 2.2 Fault Protection

All PSS products include the following protective functions, which activate the internal inhibit:

- Over-temperature  
Inhibits shunt when heatsink temperature exceeds 90 °C (194 °F).
- Duty cycle  
Inhibits shunt whenever On and Off time exceeds 5% to 10% (depending on PSS model). This feature protects the shunt regulator when high-inertia loads are driven by the servo amplifier(s) or when too high an AC voltage is applied to the power supply (i.e. DC output is already above the threshold of the shunt).

## 2.3 Block Diagram

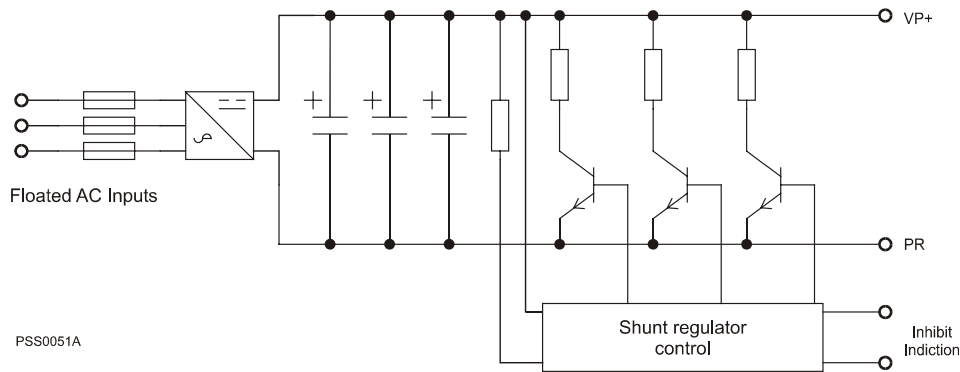

Figure 2-1: PSS Block Diagram

## 2.4 Technical Specifications

### 2.4.1 PSS Power Supplies with Shunt Regulators

Feature	Unit	PSS-15/100	PSSF-20/100	PSS-12/200	PSSF-20/200	PSS-30/200	PSSF-60/200
Minimum AC supply	VAC	14	14	42	42	3 x 42	3 x 42
Maximum AC supply	VAC	65	65	135	135	135	135
Minimum DC output	VDC	20	20	60	60	60	60
Maximum DC output $\pm 1\%$	VDC	92	92	191	191	191	191
Continuous current	A	15	20	12	20	30	60
Peak current	A	40	40	40	40	60	100
Panel size (see <a href="#">section 2.6</a> )		PS2	PS1	PS2	PS1	PS3	PS3
Rack size		3U/21T	3U/12T	3U/21T	3U/12T	6U/21T	6U/21T
Weight	Kg	1.4	0.7	1.4	0.7	3.0	3.5

### 2.4.2 Shunt Regulator Specifications

Feature	Unit	PSS-15/100	PSSF-20/100	PSS-12/200	PSSF-20/200	PSS-30/200	PSSF-60/200
Regulation voltage* $\pm 1\%$	VDC	92	92	191	191	191	191
Continuous shunt power	W	70	100	70	100	200	500**
Shunt current	A	50	50	15	15	50	80

\* The regulating voltage ( $V_r$ ) is the voltage at which the shunt regulator is activated.

\*\* Fan cooling rating

## 2.5 Dimensional Drawings

There are four basic sizes of the PSS/PSSF models:

- Panel mount PS1, for 3U/12T size
- Panel mount PS2, for 3U/21T size
- Panel mount PS3, for 6U/21T size
- Rack mount

The following sections provide dimensions of the four basic sizes. All dimensions are given in millimeters.

### 2.5.1 PS1 (for PSSF-20/100 and PSSF-20/200)



Figure 2-2: PS1 - Top View

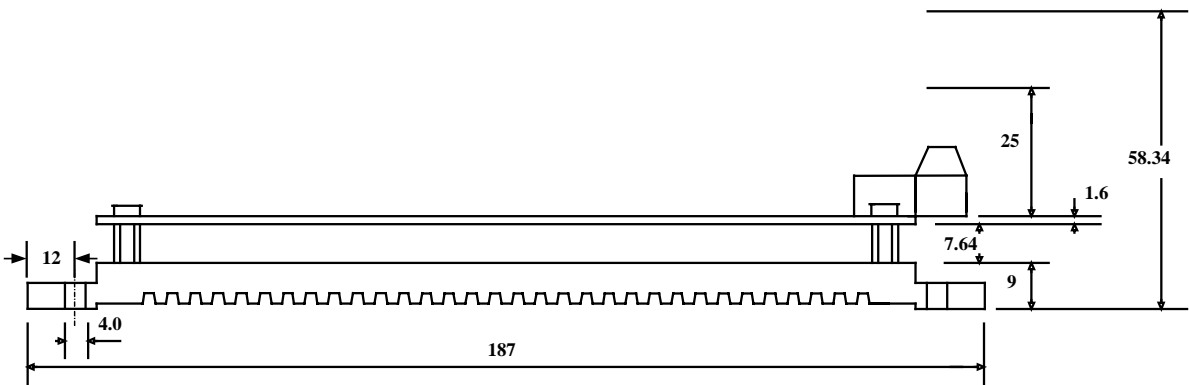

Figure 2-3: PS1 - Side View, Length

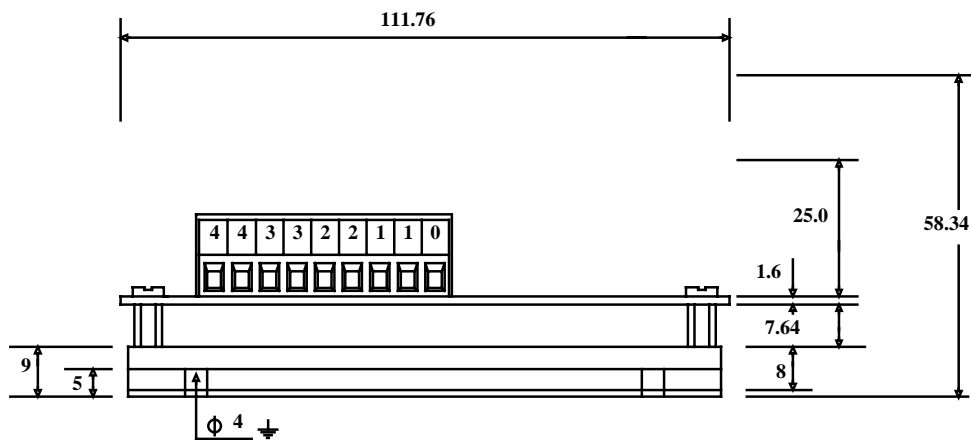

Figure 2-4: PS1 - Side View, Width

### 2.5.2 PS2 (for PSS-15/100 and PSS-12/200)

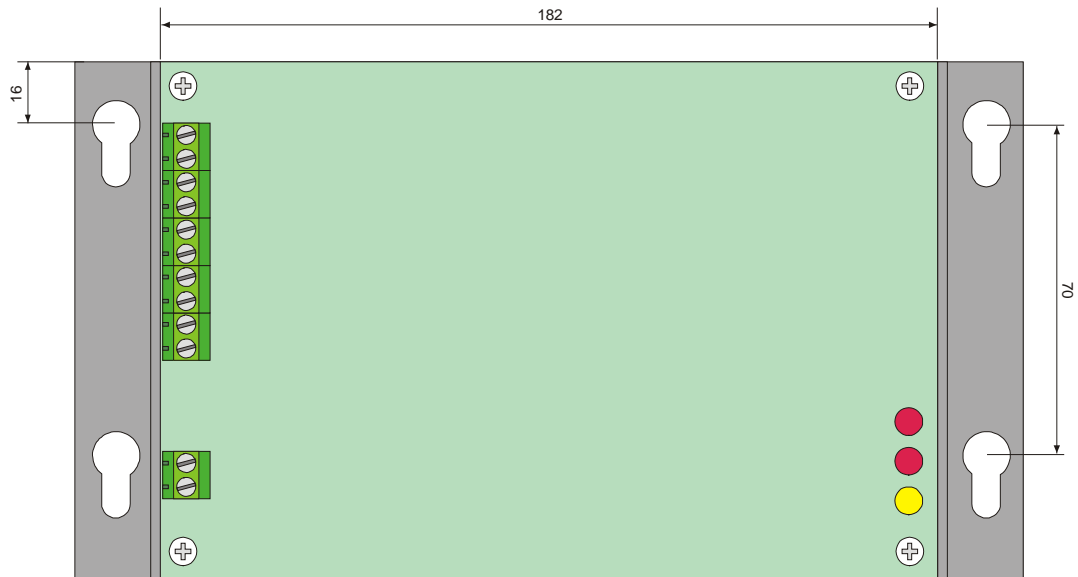

Figure 2-5: PS2 - Top View

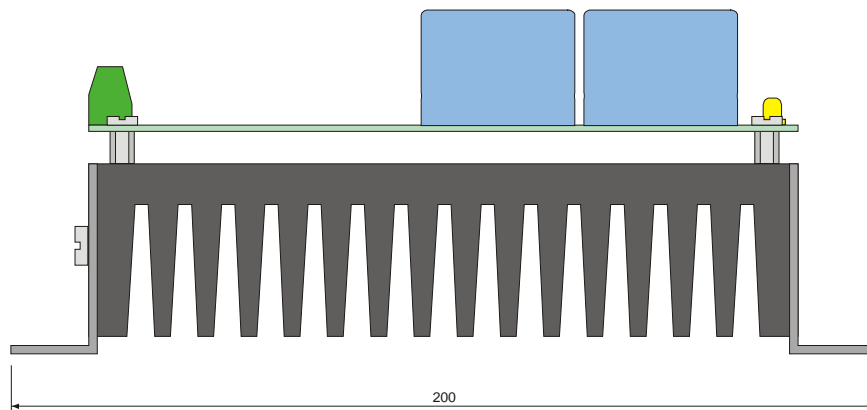

Figure 2-6: PS2 - Side View, Length

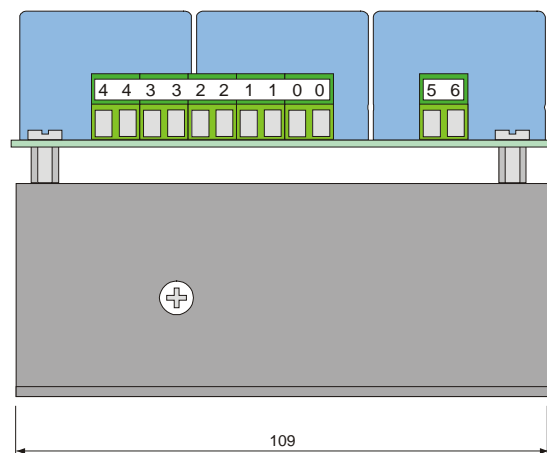

Figure 2-7: PS2 - Side View, Width

### 2.5.3 PS3 (for PSS-30/200 and PSSF-60/200\*)

\* Model PSSF-60/200 includes an integrated fan.

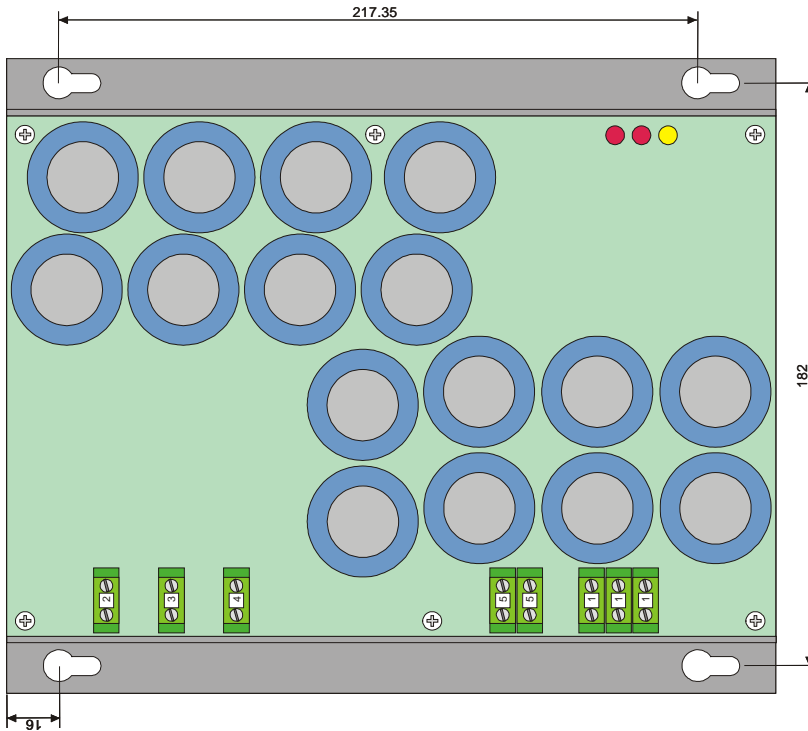

Figure 2-8: PS3 - Top View

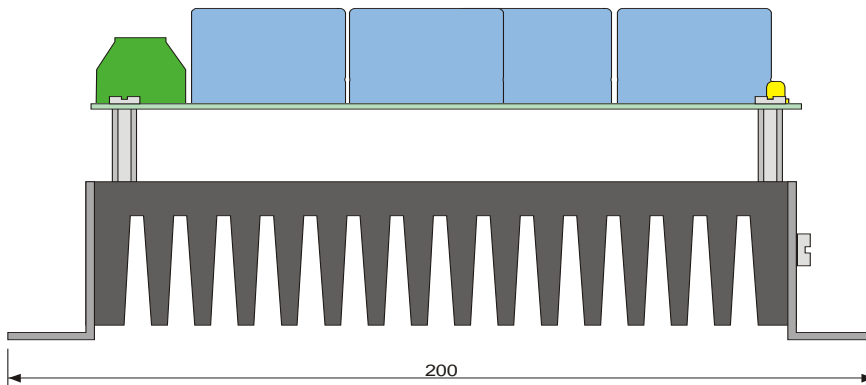

Figure 2-9: PS3 - Side View, Length

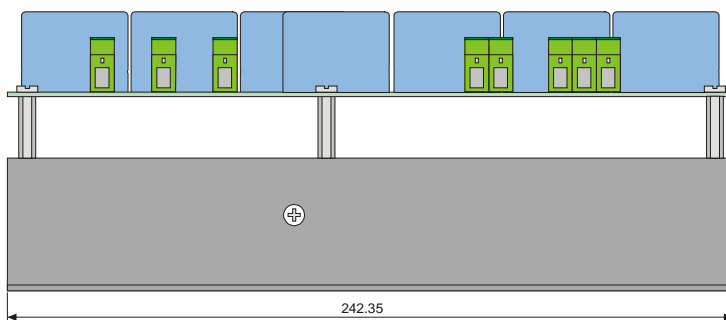

Figure 2-10: PS3 - Side View, Width

### 2.5.4 Rack Mount

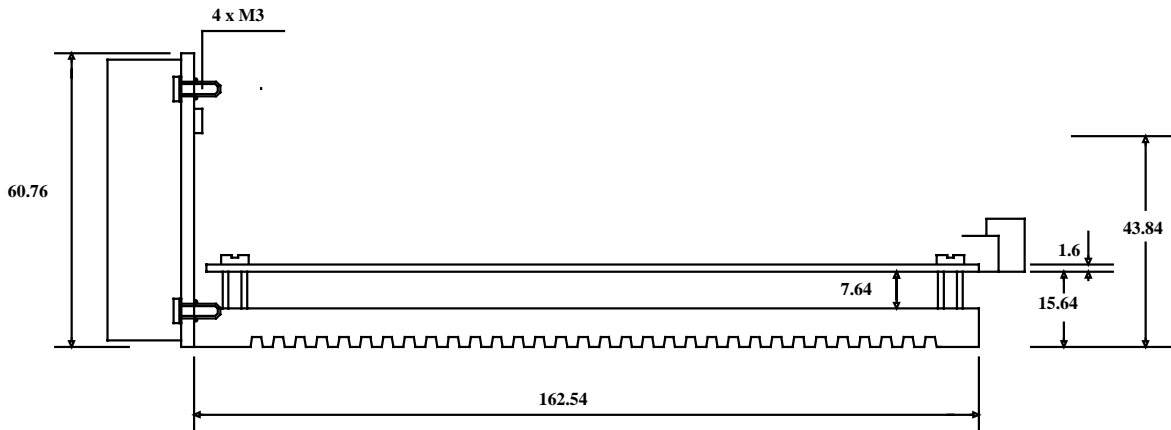

Figure 2-11: PSS Rack Mount (3U/12T): Side View, Length

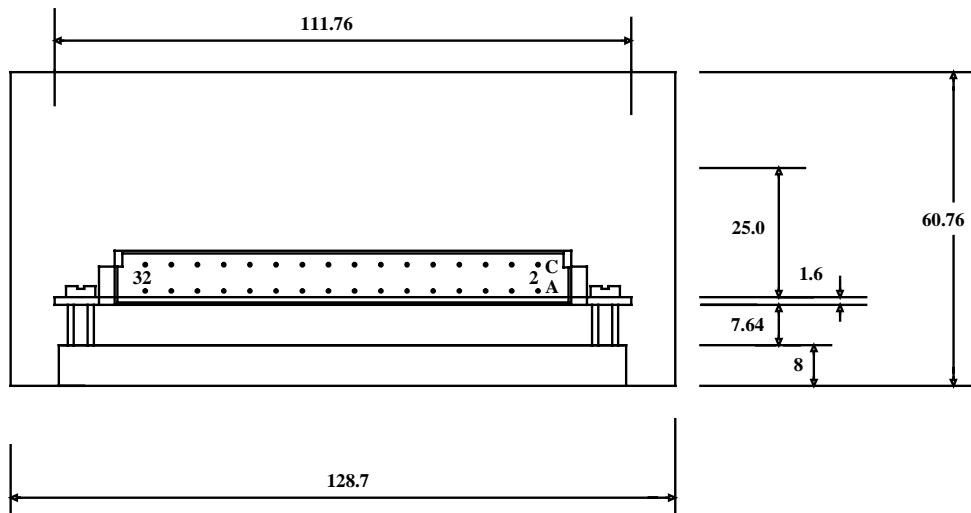

Figure 2-12: PSS Rack Mount (3U/12T): Side View, Width

 **Note:**  
Rack Mount versions of other models are available upon request.

## Chapter 3: Installation

### 3.1 Unpacking the System Components

To unpack the PSS:

Carefully remove the power supply from the box and the Styrofoam.

1. Check the supply to ensure that there is no visible damage to the instrument. If any damage has occurred, report immediately to the carrier that delivered your product.
2. To ensure that the PSS you have unpacked is the appropriate type for your requirements, find the part number sticker on the side of the supply:

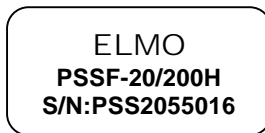

The P/N number in the middle gives the type designation as follows:

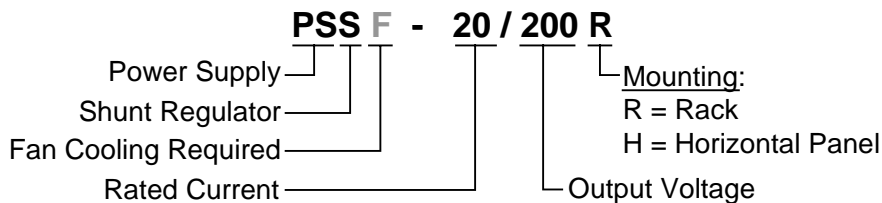

3. Verify that the PSS model is the one that you ordered, and ensure that the voltage meets your specific requirements.

### 3.2 Mounting and Wiring the PSS

For optimum heat dissipation, the power supply should be installed with the heatsink fins in the vertical direction.

#### 3.2.1 Wiring Guidelines

1. Use flexible wires with the proper cross-section to handle the unit current. Color coding is recommended.
2. After wiring is completed, carefully inspect all conditions in order to ensure tightness.

#### 3.2.2 AC Power Supplies



The PSS power supplies do not include inrush current control. Therefore, they should be connected to an isolating/floating transformer.

The AC power supply can be of any voltage in the range defined in the technical specifications (section 2.4). It must be able to deliver power to the amplifiers (including peak power), without significant drops. A three-phase supply is always recommended whenever possible, in order to provide better DC bus voltage stability (low voltage ripple) under high load conditions.

The recommended AC voltage is:

$$1.2 \times VAC (\text{min}) < VAC < 0.9 \times VAC (\text{max})$$



With a single-phase supply, a voltage drop due to loading is expected. The magnitude of the voltage drop depends on the load current, stiffness of the power source and the total bus capacitance.

### 3.2.3 Wiring Diagrams

#### 3.2.3.1 Isolated AC Supplies

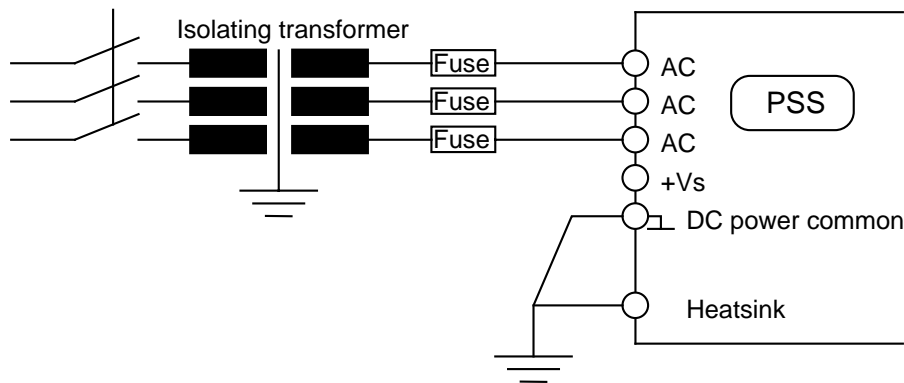

Figure 3-1: Isolated PSS Wiring

Ground the DC power common.

### 3.2.3.2 Wiring Two or More Supplies in Parallel

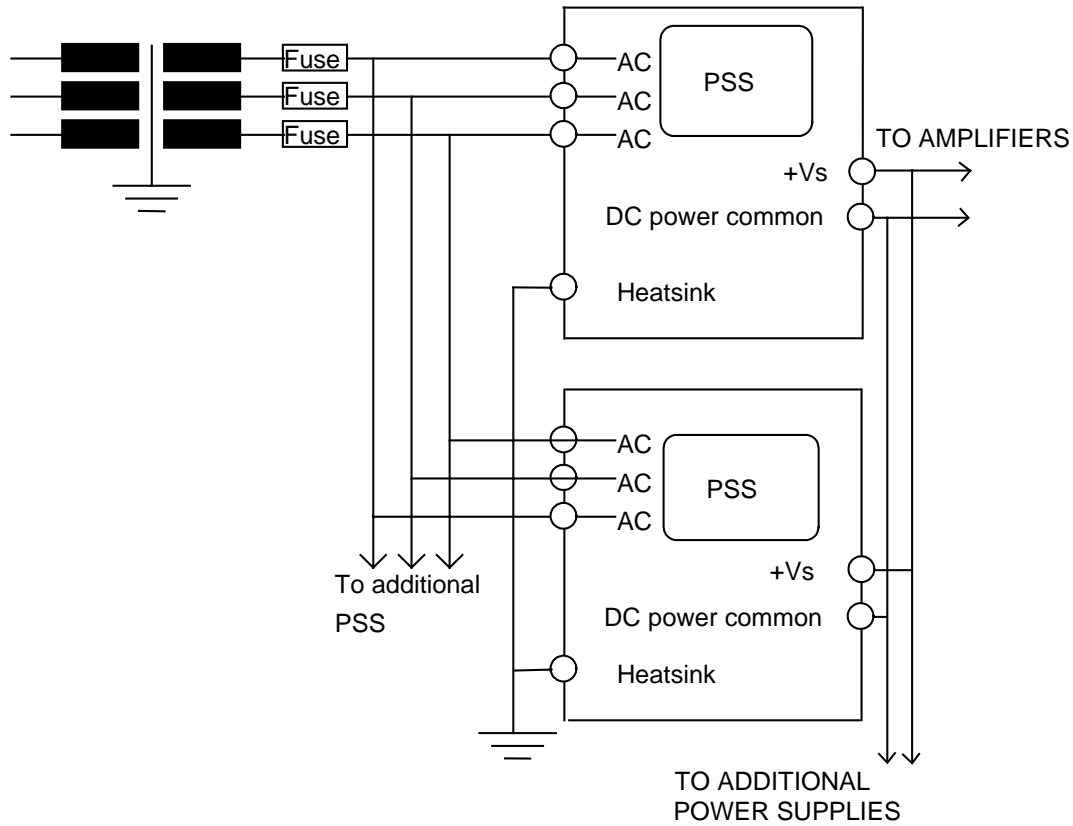

Figure 3-2: Parallel PSS Wiring

All wiring guidelines for supply connections described previously apply to multiple-PSS connections.

## 3.3 Startup Procedures

### 3.3.1 Switching from Single-phase to Three-phase (3U only)

Modifying the power supply to a three-phase connection is accomplished by removing W2 and connecting the third phase to terminal 1.

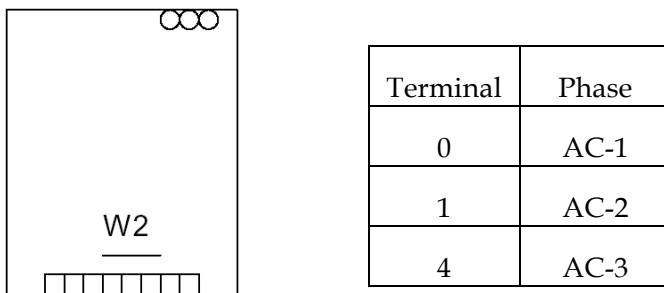

Figure 3-3: Converting a Single-phase Connection to a Three-phase Connection

### 3.3.2 Capacitor Reforming



All PSS power supplies undergo capacitor reforming prior to shipment to the customer. However, if the power supply has been idle (at the customer site) for a period of nine months or more, the capacitors must be reformed before startup.

*To perform capacitor reforming:*

1. Connect a 25-VAC supply at the AC input terminals and a 100-W/220-V (or 50W/110-VAC) light bulb at the power output terminals.
2. Run the power supply for an hour and then increase the voltage to 50 VAC for an additional hour.
3. For higher-voltage types, run the supply for another hour at 100 VAC.

**Noncompliance with these instructions may result in capacitor failure.**

### 3.3.3 LED Diagnostics

The following LEDs are mounted on the PSS:

<b>LED</b>	<b>Indication</b>
L1 (Vs)	Existence of internal supply.
L2 (SO)	Shunt is on.
L3 (In)	Shunt is inhibited.