

Haydon™ LRS™ – Linear Rail Systems slide technology



Haydon Linear Rail Systems (LRS) use a precision leadscrew assembly mechanism to provide controlled positioning along the axis of a robust aluminum linear slide. The LRS consists of a stationary base with a load bearing carriage that travels along a custom-extruded aluminum rail of varying lengths. The carriage is a small platform with sliding element linear bearings that glide within this specially configured extrusion. The leadscrew used in the system is provided with various leads and shaft end configurations that accommodate virtually any source of rotary power.

Key Product Features

- “T” slots integrated into exterior rail bottom and sides that accommodate full length support and various mounting options.
- Loads easily attach to the compact, moving carriage with four or six M4 x 0.7 size screws.
- Load bearing carriage moves efficiently and smoothly within the internal rail geometry of this specially designed aluminum extrusion.
- Rail provides end-to-end axial stability and precise motion system accuracy.
- Automatic adjustments of slide bearing play with a patent pending “anti-backlash” linear bearing.
- Rated life equals that of the existing leadscrews of similar size.
- Leadscrew end configurations adapt to various rotary motion sources.
- Kerkote® or Black Ice™ TFE coatings on a 303 stainless steel leadscrew.
- Designed to Metric global engineering standards.
- For extreme control, LRS can be used with CMP or WDG high-precision anti-backlash nuts, as well as a freewheeling general purpose nut.

Performance Specifications

Width	Length of Stroke (max)	Speed (max)	Straight Line Accuracy	Twist
1-5/8-in square (4.3 cm square)	40-in (1000 mm)	20-in/sec (0.5 M/sec)	+/- 0.012-in/ft (+/- 1.0 mm/M)	+/- 0.25°/ft (+/- 0.75°/M)

Load Ratings (max)

Top Load “Z” Direction	Hanging / Gantry	Max. Pitch Moment	Max. Moment Roll	Max. Moment Yaw
50 lbs (225 N)	50 lbs (225 N)	75-in – lbs (8.5 N – M)	75-in – lbs (8.5 N – M)	75-in – lbs (8.5 N – M)

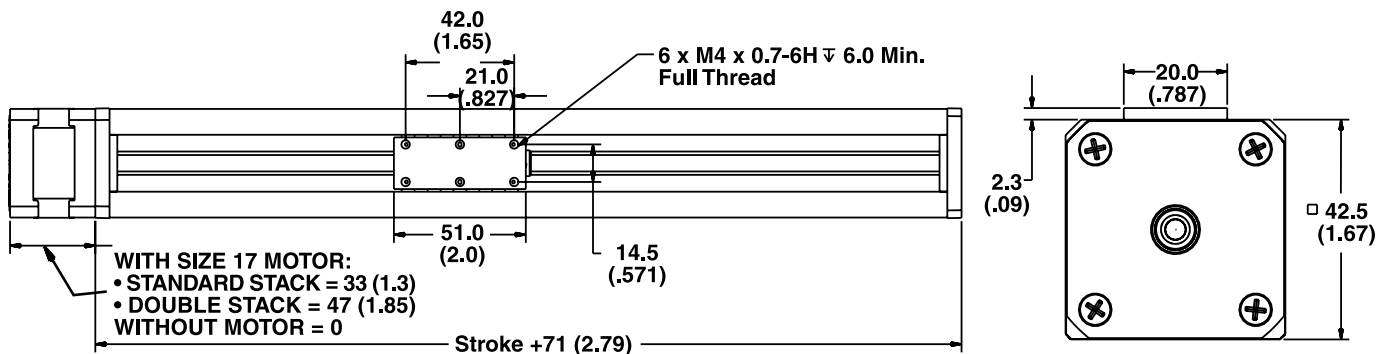
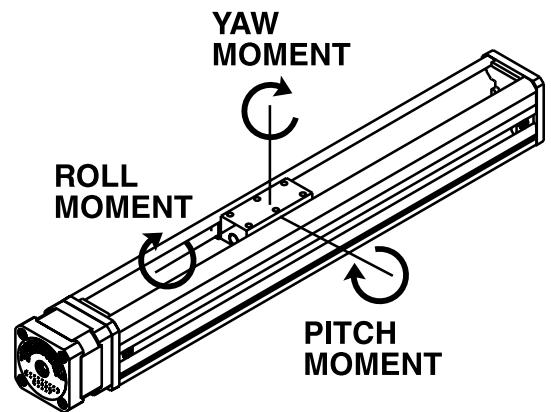

LRS™ LINEAR RAIL SYSTEMS
SLIDE TECHNOLOGY

Identifying the part number codes when ordering

LR	W	04	B	R	M	43	0025	12	XXX
Prefix: LR = Linear Rail System (LRS)	Nut Style B = BFW nut W = WDG nut G = Guide only	Rail Frame Size: 04 = 50 lbs	Coating S = Uncoated B = Black Ice™ N = No screw	Thread R = Right hand L = Left hand N = No screw X = Custom	Drive/Mounting A = None B = No motor, in-line motor mount M = Motorized	Motor Frame 00 = No motor 43 = Size 17 Stepper Motor XX = Custom	Nominal Thread Lead Code (in inches) 0000 = No screw	Stroke (in inches rounded up) 07 = 7-in 08 = 8-in 12 = 12-in (up to 40-in max.)	Unique Identifier Number assigned by Haydon Kerk Motion Solutions (for added features such as custom configurations, etc.)

Select from Lead Code Chart

Lead (inch)	Lead (mm)	Thread Lead Code
0.025	0.635	0025
0.03125	0.794	0031
0.0394	1.0	0039
0.05	1.27	0050
0.0625	1.588	0063
0.0787	2.0	0079
0.1	2.54	0100
0.125	3.175	0125
0.1969	5.0	0197
0.25	6.35	0250
0.3937	10.0	0394
0.5	12.7	0500
0.75	19.05	0750
1.0	25.4	1000

LRS™ - Linear Rail Systems powered slide technology

For optimum performance, the system can be fitted with the Haydon™ patented, Size 17 Hybrid Linear Actuators available in a wide variety of resolutions - from 0.001524 mm (0.00006-in) per step to 0.048768 mm (0.00192-in) per step, and delivers thrust of up to 222 N (50 lbs.). For greater performance Size 17 Hybrid Double Stack Linear Actuators provide 0.0158 mm (0.000625-in) per step to 0.127 mm (0.005-in) per step and delivers thrust of up to 337 N (75 lbs.).



- 42.5 cm (16-5/8 in.) x 4.3 cm (1-5/8 in.) sq., Black Ice™ PTF Leadscrew with Size 17 Hybrid Linear Actuator
- 27.5 cm (10-3/4 in.) x 4.3 cm (1-5/8 in.) sq., Black Ice™ Lead-screw, with Size 17 Double Stack Hybrid Linear Actuator



HOW TO ORDER EXAMPLES:

LRW04BR-M43-0025-12-XXX = Linear Rail System, WDG anti-backlash nut, standard linear rail, Black Ice TFE coated screw, right hand thread, motorized, Size 17 stepper motor, 0.025-in lead, 12-in stroke, with no additional unique feature

LRG04NN-A00-0000-12-XXX = Linear Rail System, guide only, standard linear rail, guide only (no screw), no motor, 12-in stroke, with no additional unique feature

For applications assistance or order entry, call the Haydon Kerk Motion Solutions Linear Rails technical advisors at 203.756.7441. Other systems may be available. Visit www.HaydonKerk.com for recent updates.