

## VL-ST45 Product Specifications

Parameter	Value	Units
<b>Configuration &amp; Physical Parameters</b>		
Motor	Animatics SmartMotors Size 23	-
Coupling	Beam	-
Ball Screw Leads	6, 12	mm/rev
Position Sensors	consult factory	-
Stroke Lengths	50-500mm in 50mm steps	mm
Overall Length	Stroke + 222	mm
Over-Travel	Approx 10	mm
Unit Mass	$1.38 + (\text{stroke, mm}) \cdot 0.0021$	kg
<b>Performance</b>		
Unidirectional Repeatability	20	$\mu\text{m}$
Bi-directional Repeatability	40	$\mu\text{m}$
Accuracy	0.021/300	mm/mm
Max Velocity	up to 1000 (stroke dependant)	mm/s
Max Acceration	0.3	G
Leads	6      12	mm/rev
Payload Mass	8      6.5	kg
Rated Velocity	200      400	mm/s
Lifetime*	15000	hr
<b>Load Capacities, Dynamic* (Static)</b>		
Max Continuous Thrust	488      245	N
Max Peak Thrust	660      330	N
M.a, Carriage Moment	4.47 (31)      3.44 (31)	N*m
M.b, Carriage Moment	1.64 (12)      1.33 (12)	N*m
M.b, Carriage Moment	1.64 (12)      1.33 (12)	N*m

\* Based on operating at an average speed of the rated velocity at the given payload. The Lifetime will be significantly reduced operating above the Rated Velocity and/or given payload.

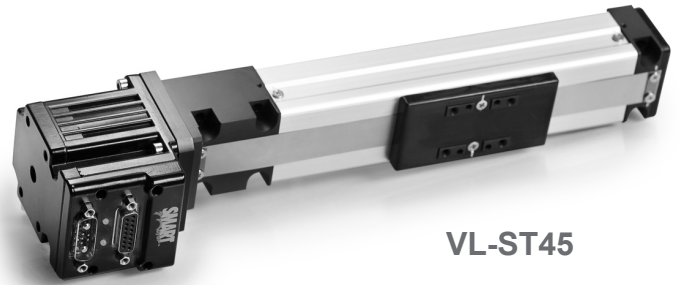

VL-ST45

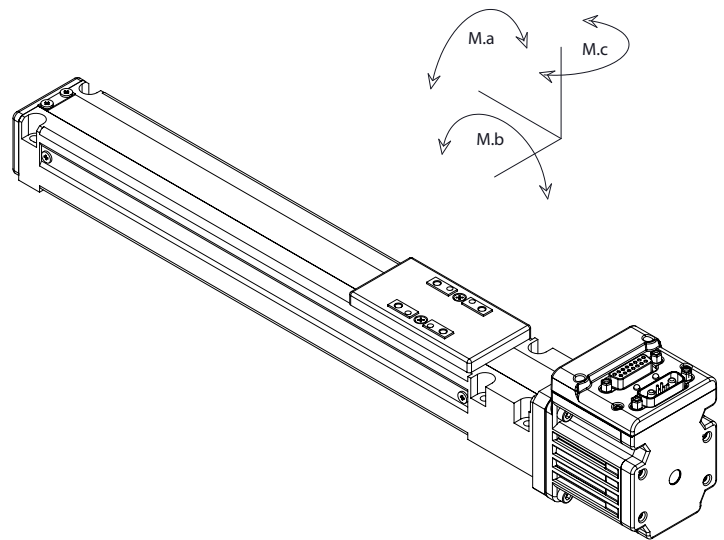

### WARNING: Do not exceed these limits

VL-ST45 - Maximum Permissible Carriage Velocity

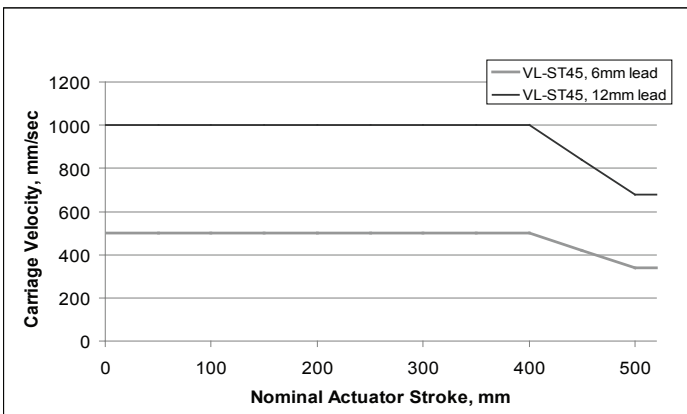

VL-ST series - Maximum Permissible Screw Speed

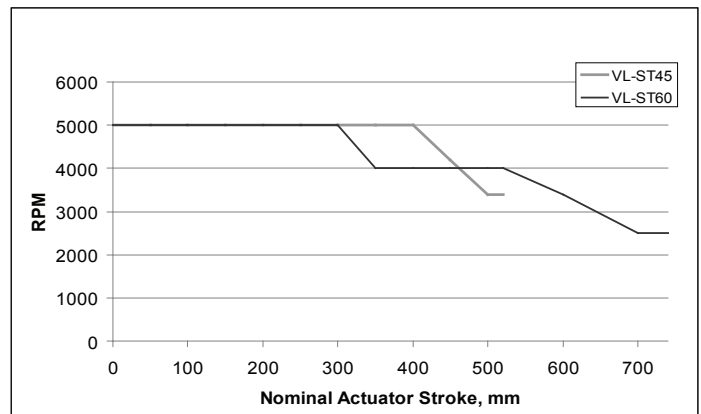

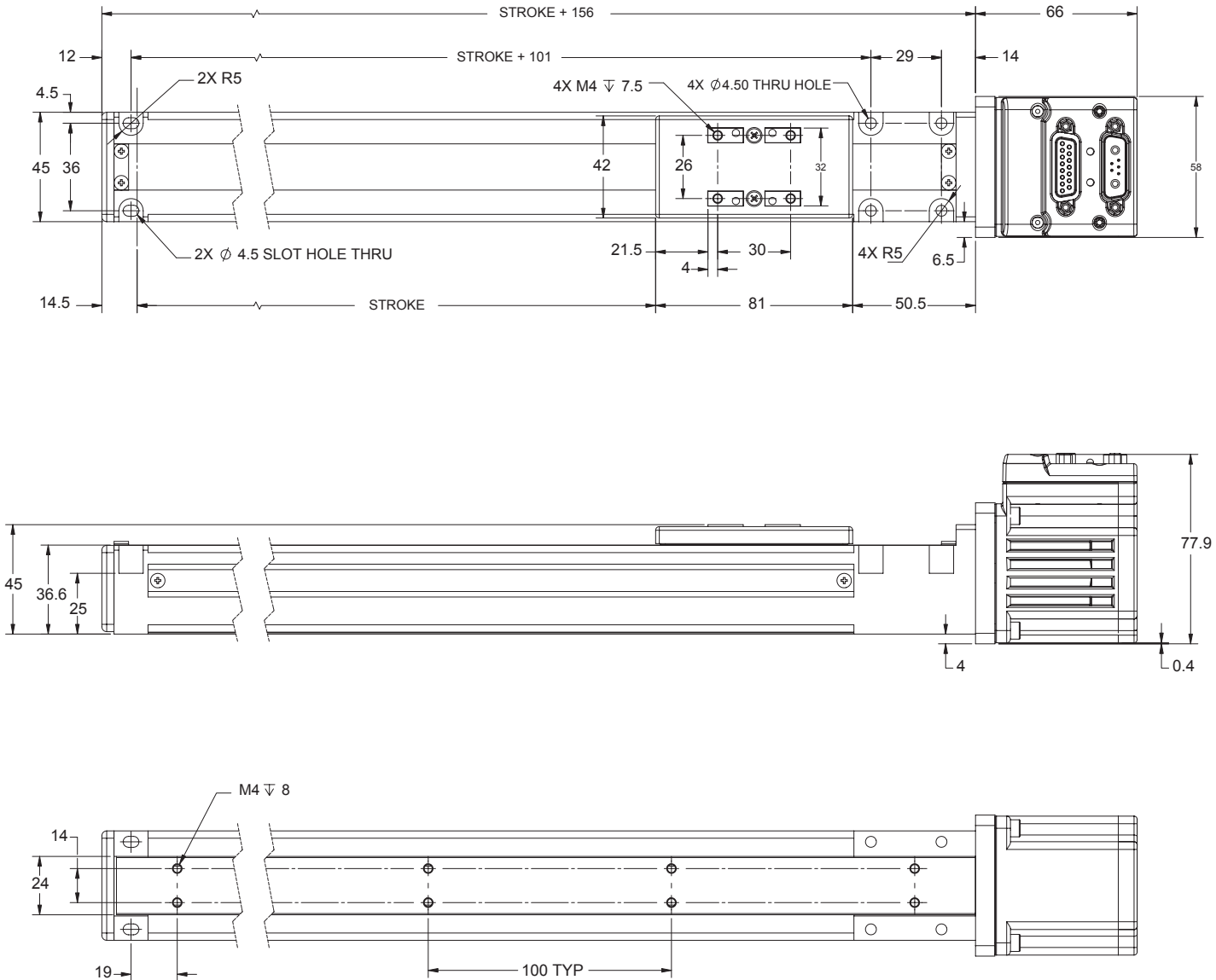

Dimensions in millimeters

Note: For part numbers please refer to our Website at [www.oemdynamics.com/partnumbers](http://www.oemdynamics.com/partnumbers) or to catalog page 5.

**Thrust Curve performance data in following section on pages 56-59.**

## VL-ST60 Product Specifications

Parameter	Value	Units	
<b>Configuration &amp; Physical Parameters</b>			
Motor	Animatics SmartMotors Size 23	-	
Coupling	Beam	-	
Ball Screw Leads	6, 12	mm/rev	
Position Sensors	consult factory	-	
Stroke Lengths	50-600mm in 50mm steps + 700mm	mm	
Overall Length	Stroke + 156 + motor	mm	
Over-Travel	Approx 10	mm	
Unit Mass	1.3349 + (stroke, mm)*0.0039	kg	
<b>Performance</b>			
Unidirectional Repeatability	20	µm	
Bi-directional Reapeatability	40	µm	
Accuracy	0.021/300	mm/mm	
Max Velocity	250 -1000 (stroke dependant)	mm/s	
Max Acceration	0.3	G	
Leads	6	12	mm/rev
Payload Mass	13	10	kg
Rated Velocity	200	400	mm/s
Lifetime*	15000	hr	
<b>Load Capacities, Dynamic* (Static)</b>			
Max Continuous Thrust	491	245	N
Max Peak Thrust	788	394	N
M.a, Carriage Moment	11.47 (58)	9 (58)	N*m
M.b, Carriage Moment	3.57 (25)	2.75 (25)	N*m
M.b, Carriage Moment	3.57 (25)	2.75 (25)	N*m

\* Based on operating at an average speed of the rated velocity at the given payload. The Lifetime will be significantly reduced operating above the Rated Velocity and/or given payload



VL-ST60

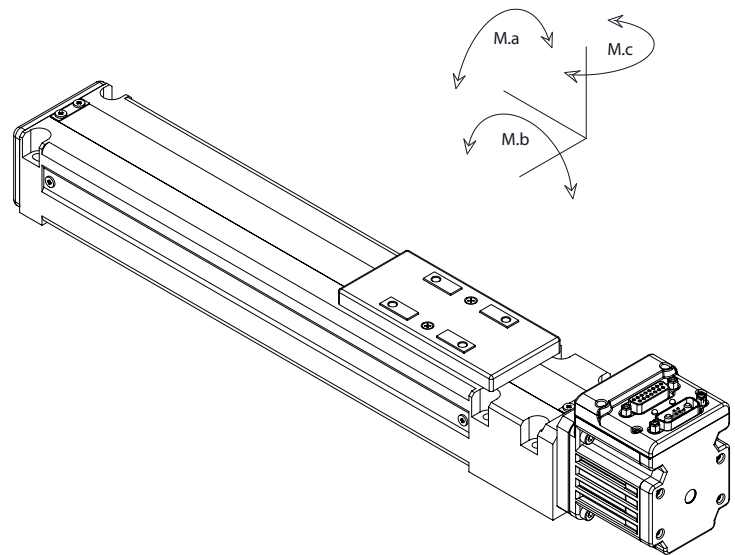

**WARNING: Do not exceed these limits**

VL-ST60 - Maximum Permissible Carriage Velocity

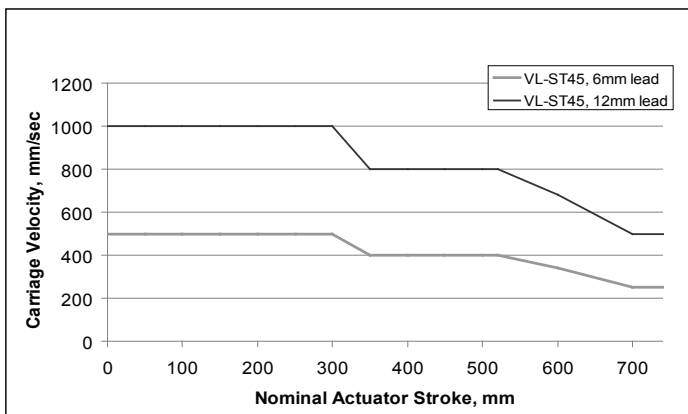

VL-ST series - Maximum Permissible Screw Speed

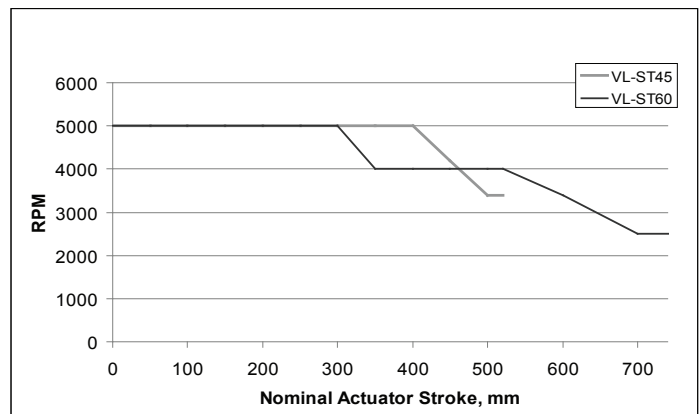



THRUST CURVES

**VL-ST45 - SM2316DT @ 48V, 6mm/rev lead ball screw**

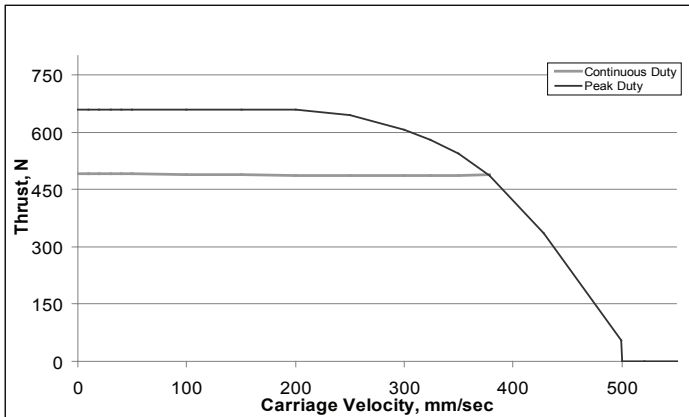

\*80 N Dynamic Thrust Limit for Basic Service Life when operated at critical speed limits within average speed requirements stated on page 24.

**VL-ST45 - SM2316DT @ 48V, 12mm/rev lead ball screw**

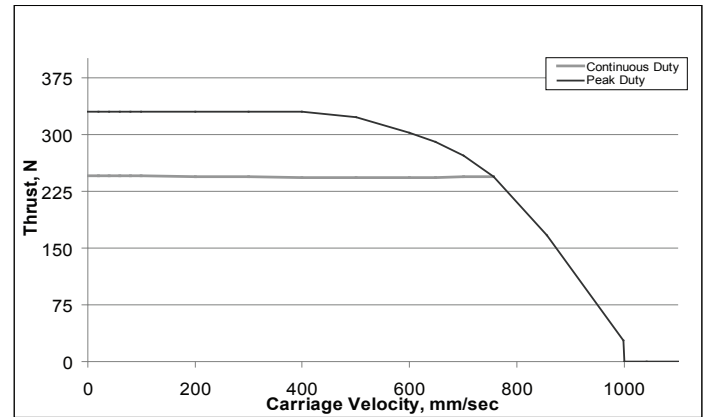

\*65 N Dynamic Thrust Limit for Basic Service Life when operated at critical speed limits within average speed requirements stated on page 24.

**VL-ST45 - SM2316DT @ 42V, 6mm/rev lead ball screw**

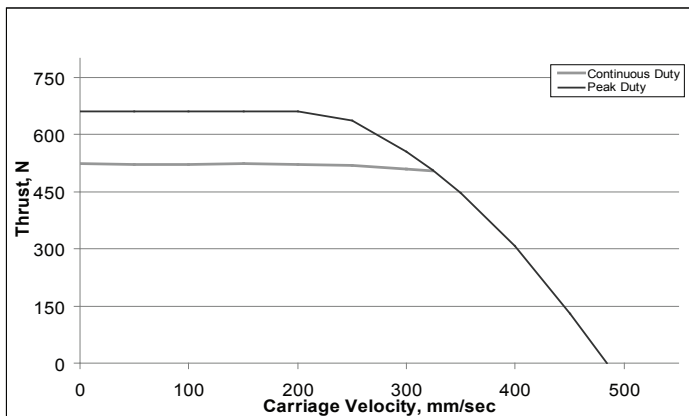

\*80 N Dynamic Thrust Limit for Basic Service Life when operated at critical speed limits within average speed requirements stated on page 24.

**VL-ST45 - SM2316DT @ 42V, 12mm/rev lead ball screw**

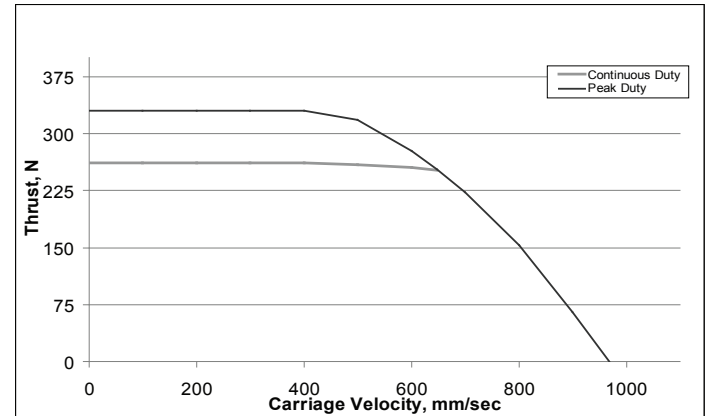

\*65 N Dynamic Thrust Limit for Basic Service Life when operated at critical speed limits within average speed requirements stated on page 24.

**VL-ST45 - SM2316DT @ 24V, 6mm/rev lead ball screw**

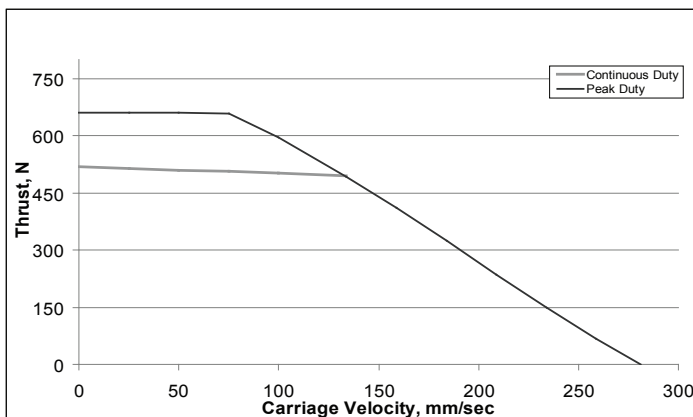

\*80 N Dynamic Thrust Limit for Basic Service Life when operated at critical speed limits within average speed requirements stated on page 24.

**VL-ST45 - SM2316DT @ 24V, 12mm/rev lead ball screw**

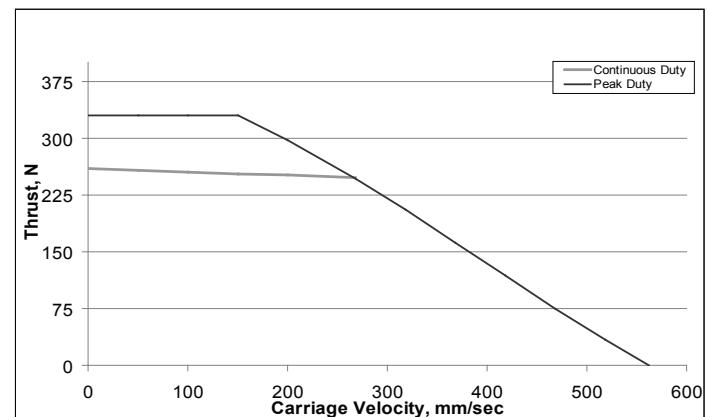

\*65 N Dynamic Thrust Limit for Basic Service Life when operated at critical speed limits within average speed requirements stated on page 24.

**VL-ST45 - SM2315DT @ 48V, 6mm/rev lead ball screw**

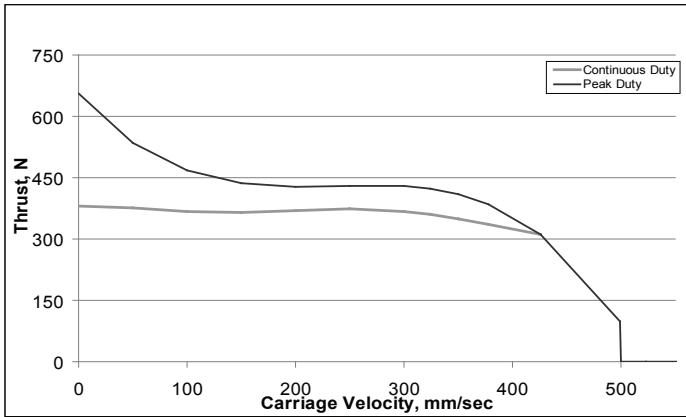

\*80 N Dynamic Thrust Limit for Basic Service Life when operated at critical speed limits within average speed requirements stated on page 24.

**VL-ST45 - SM2315DT @ 48V, 12mm/rev lead ball screw**

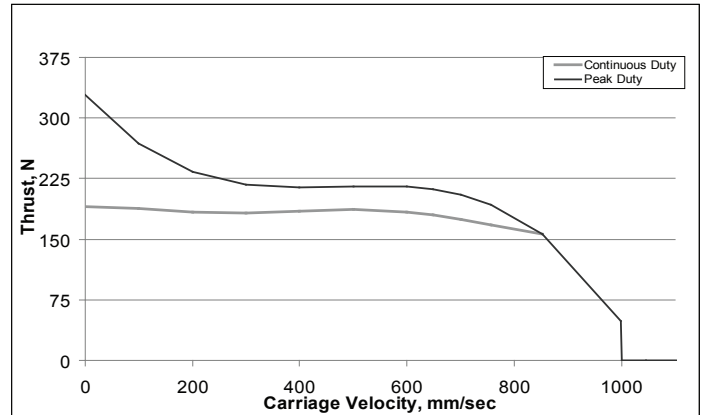

\*65 N Dynamic Thrust Limit for Basic Service Life when operated at critical speed limits within average speed requirements stated on page 24.

**VL-ST45 - SM2315DT @ 42V, 6mm/rev lead ball screw**

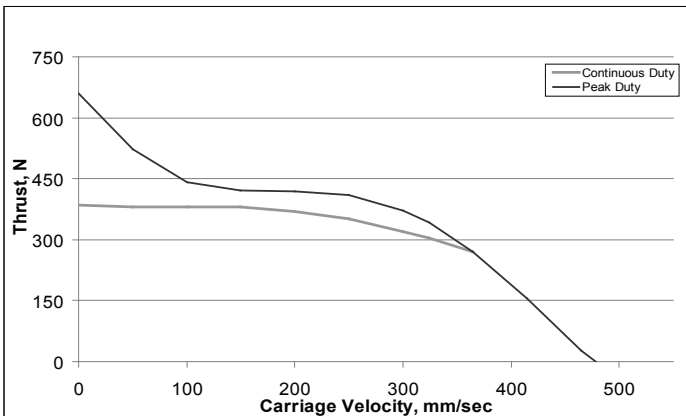

\*80 N Dynamic Thrust Limit for Basic Service Life when operated at critical speed limits within average speed requirements stated on page 24.

**VL-ST45 - SM2315DT @ 42V, 12mm/rev lead ball screw**

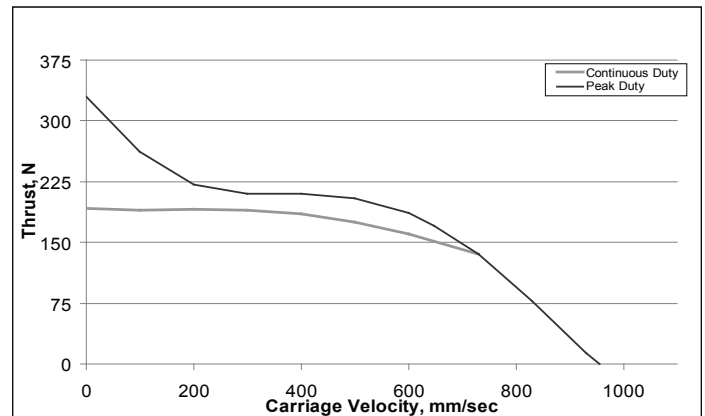

\*65 N Dynamic Thrust Limit for Basic Service Life when operated at critical speed limits within average speed requirements stated on page 24.

**VL-ST45 - SM2315DT @ 24V, 6mm/rev lead ball screw**

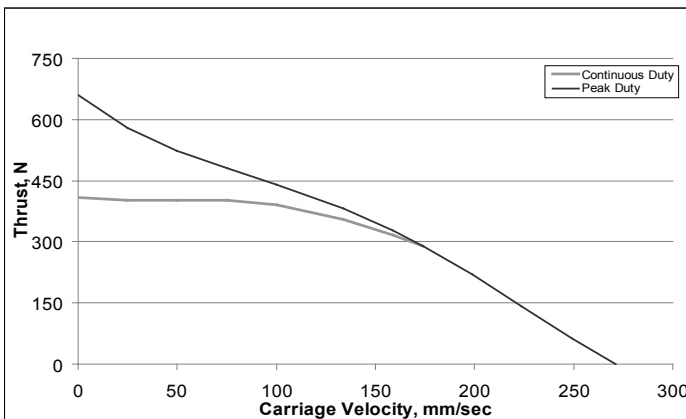

\*80 N Dynamic Thrust Limit for Basic Service Life when operated at critical speed limits within average speed requirements stated on page 24.

**VL-ST45 - SM2315DT @ 24V, 12mm/rev lead ball screw**

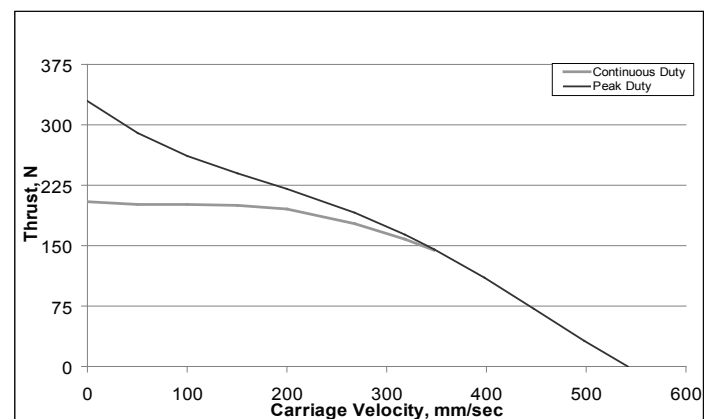

\*65 N Dynamic Thrust Limit for Basic Service Life when operated at critical speed limits within average speed requirements stated on page 24.

**VL-ST45 - SM2316D @ 48V, 6mm/rev lead ball screw**

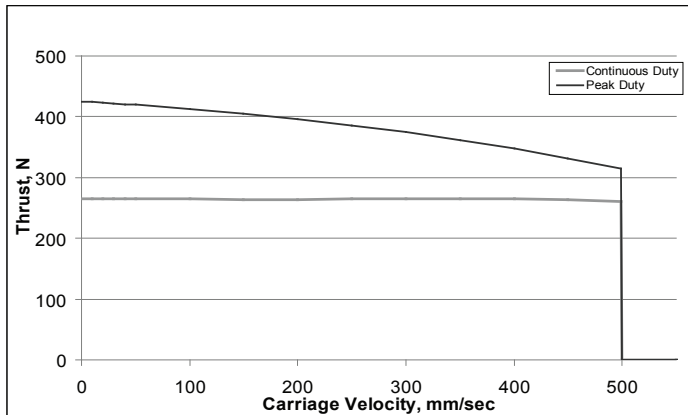

\*80 N Dynamic Thrust Limit for Basic Service Life when operated at critical speed limits within average speed requirements stated on page 24.

**VL-ST45 - SM2316D @ 48V, 12mm/rev lead ball screw**

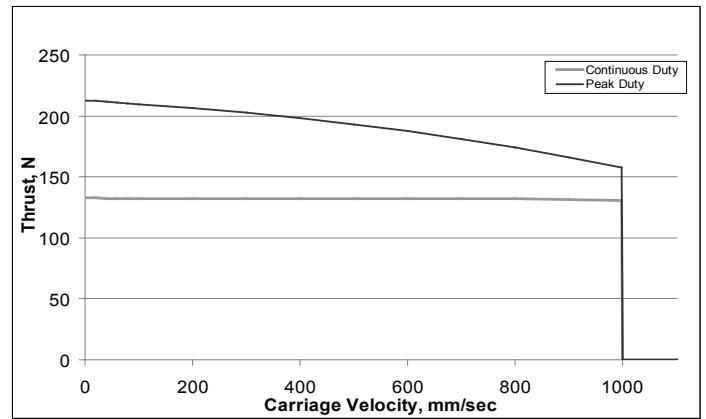

\*65 N Dynamic Thrust Limit for Basic Service Life when operated at critical speed limits within average speed requirements stated on page 24.

**VL-ST45 - SM2316D @ 42V, 6mm/rev lead ball screw**

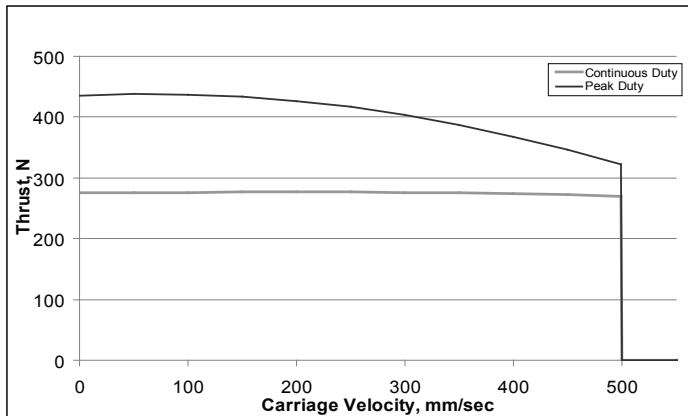

\*80 N Dynamic Thrust Limit for Basic Service Life when operated at critical speed limits within average speed requirements stated on page 24.

**VL-ST45 - SM2316D @ 42V, 12mm/rev lead ball screw**

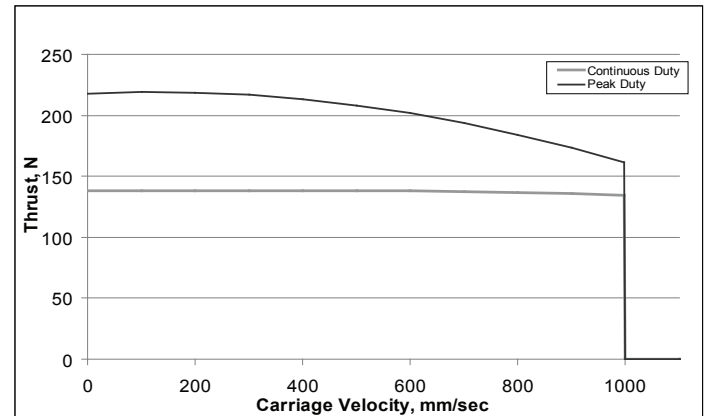

\*65 N Dynamic Thrust Limit for Basic Service Life when operated at critical speed limits within average speed requirements stated on page 24.

**VL-ST45 - SM2316D @ 24V, 6mm/rev lead ball screw**

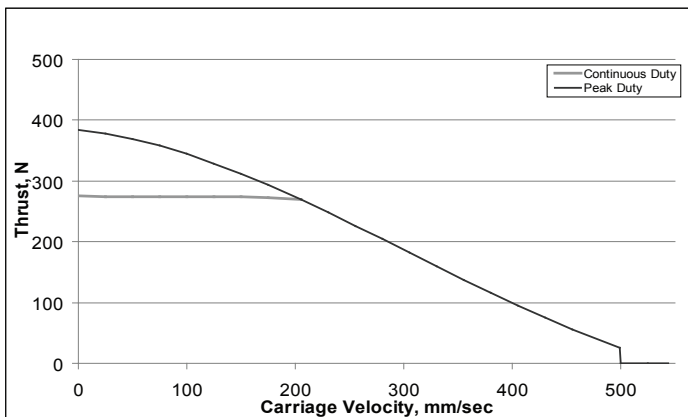

\*80 N Dynamic Thrust Limit for Basic Service Life when operated at critical speed limits within average speed requirements stated on page 24.

**VL-ST45 - SM2316D @ 24V, 12mm/rev lead ball screw**

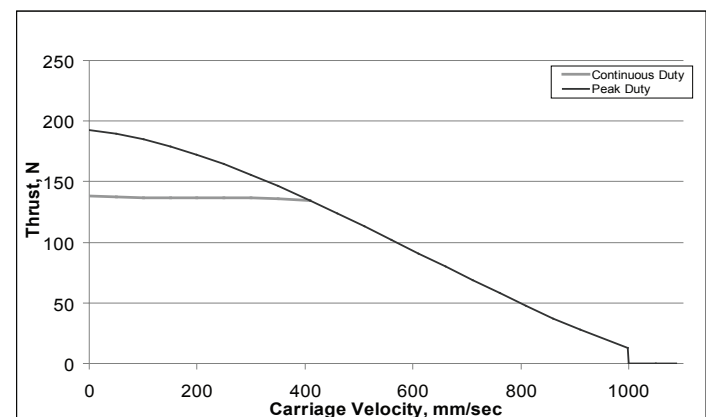

\*65 N Dynamic Thrust Limit for Basic Service Life when operated at critical speed limits within average speed requirements stated on page 24.

THRUST CURVES

**VL-ST45 - SM2315D @ 48V, 6mm/rev lead ball screw**

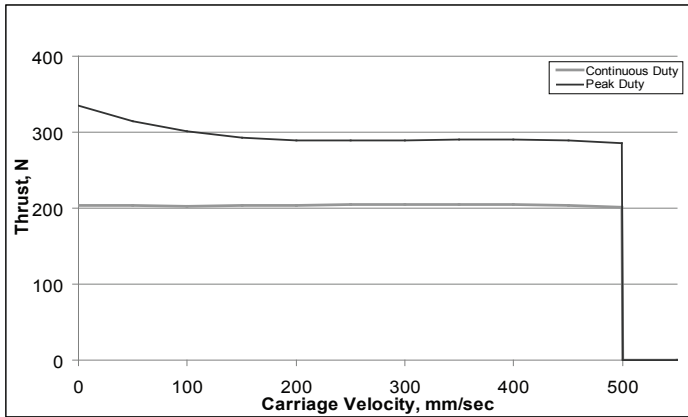

\*80 N Dynamic Thrust Limit for Basic Service Life when operated at critical speed limits within average speed requirements stated on page 24.

**VL-ST45 - SM2315D @ 48V, 12mm/rev lead ball screw**

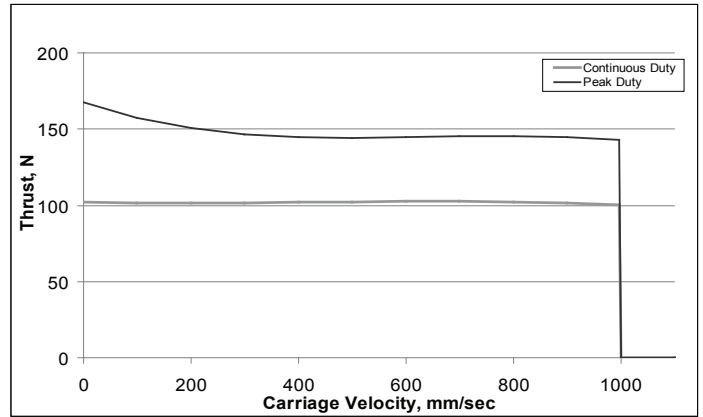

\*65 N Dynamic Thrust Limit for Basic Service Life when operated at critical speed limits within average speed requirements stated on page 24.

**VL-ST45 - SM2315D @ 42V, 6mm/rev lead ball screw**

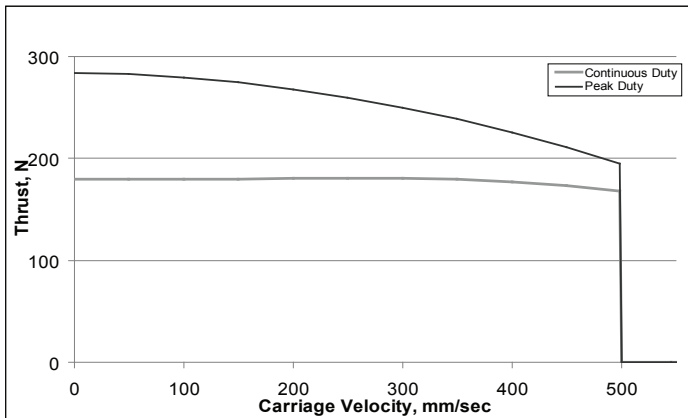

\*80 N Dynamic Thrust Limit for Basic Service Life when operated at critical speed limits within average speed requirements stated on page 24.

**VL-ST45 - SM2315D @ 42V, 12mm/rev lead ball screw**

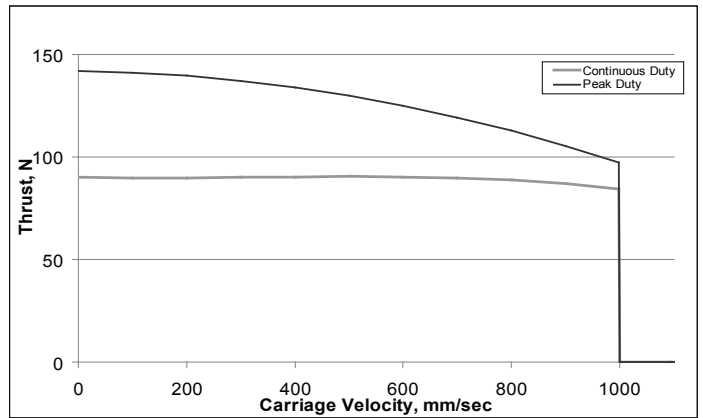

\*65 N Dynamic Thrust Limit for Basic Service Life when operated at critical speed limits within average speed requirements stated on page 24.

**VL-ST45 - SM2315D @ 24V, 6mm/rev lead ball screw**

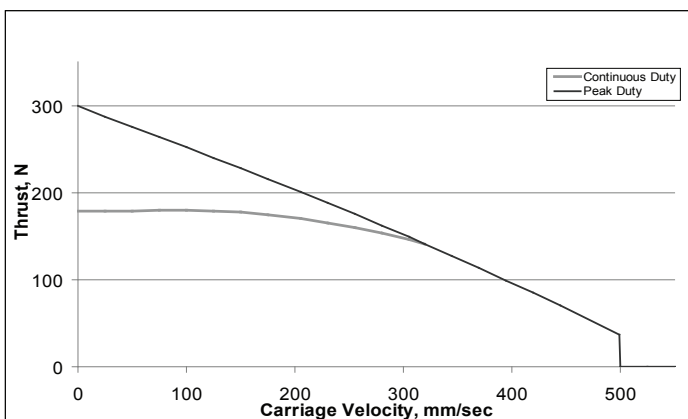

\*80 N Dynamic Thrust Limit for Basic Service Life when operated at critical speed limits within average speed requirements stated on page 24.

**VL-ST45 - SM2315D @ 24V, 12mm/rev lead ball screw**

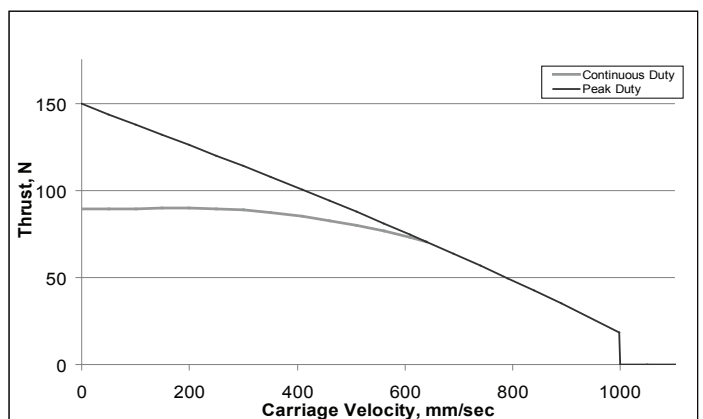

\*65 N Dynamic Thrust Limit for Basic Service Life when operated at critical speed limits within average speed requirements stated on page 24.

**VL-ST60 - SM2316DT @ 48V, 6mm/rev lead ball screw**

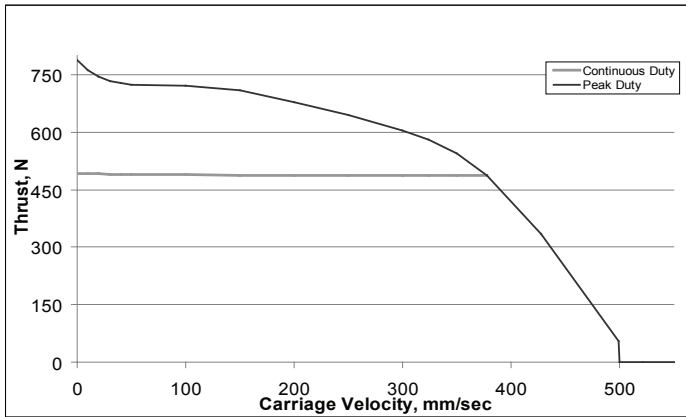

\*130 N Dynamic Thrust Limit for Basic Service Life when operated at critical speed limits within average speed requirements stated on page 26.

**VL-ST60 - SM2316DT @ 48V, 12mm/rev lead ball screw**

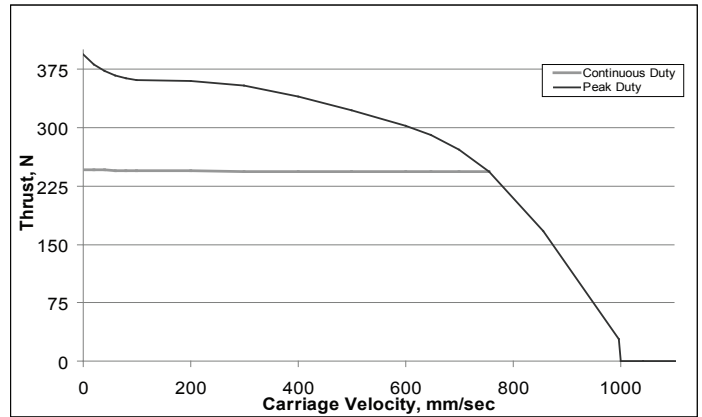

\*100 N Dynamic Thrust Limit for Basic Service Life when operated at critical speed limits within average speed requirements stated on page 26.

**VL-ST60 - SM2316DT @ 42V, 6mm/rev lead ball screw**

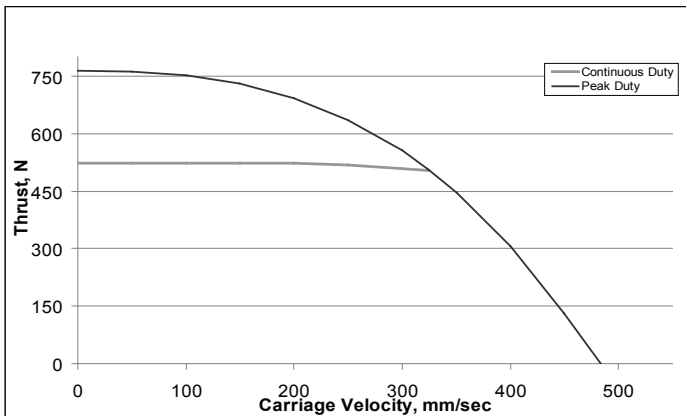

\*130 N Dynamic Thrust Limit for Basic Service Life when operated at critical speed limits within average speed requirements stated on page 26.

**VL-ST60 - SM2316DT @ 42V, 12mm/rev lead ball screw**

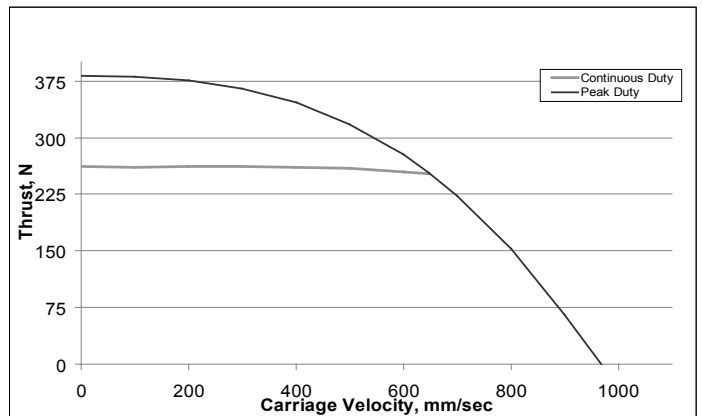

\*100 N Dynamic Thrust Limit for Basic Service Life when operated at critical speed limits within average speed requirements stated on page 26.

**VL-ST60 - SM2316DT @ 24V, 6mm/rev lead ball screw**

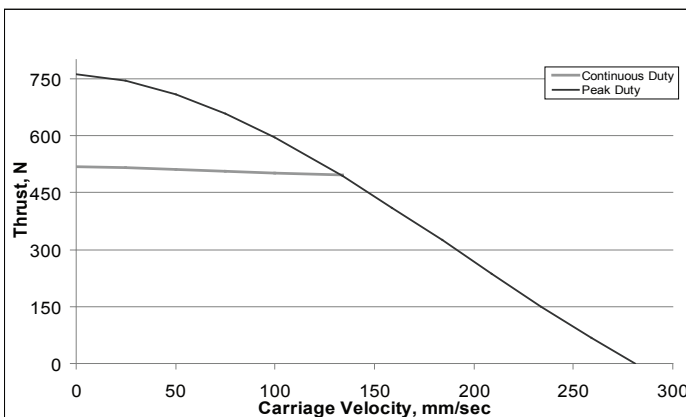

\*130 N Dynamic Thrust Limit for Basic Service Life when operated at critical speed limits within average speed requirements stated on page 26.

**VL-ST60 - SM2316DT @ 24V, 12mm/rev lead ball screw**

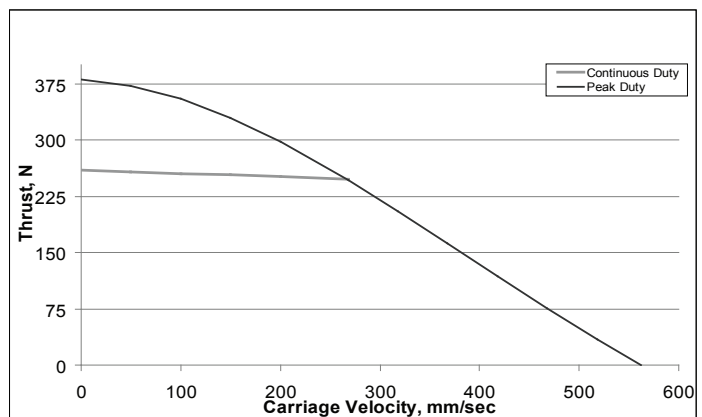

\*100 N Dynamic Thrust Limit for Basic Service Life when operated at critical speed limits within average speed requirements stated on page 26.

**VL-ST60 - SM2315DT @ 48V, 6mm/rev lead ball screw**

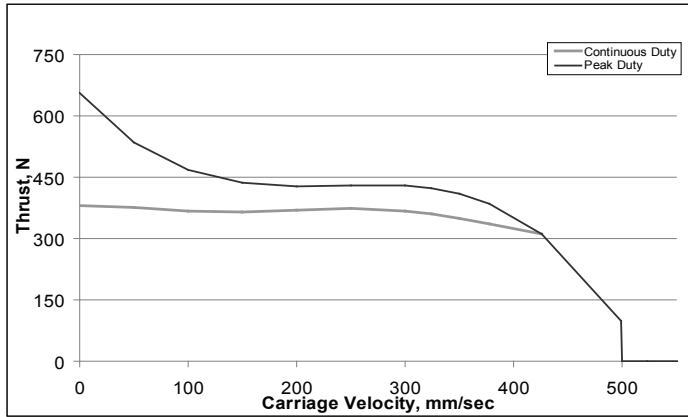

\*130 N Dynamic Thrust Limit for Basic Service Life when operated at critical speed limits within average speed requirements stated on page 26.

**VL-ST60 - SM2315DT @ 48V, 12mm/rev lead ball screw**

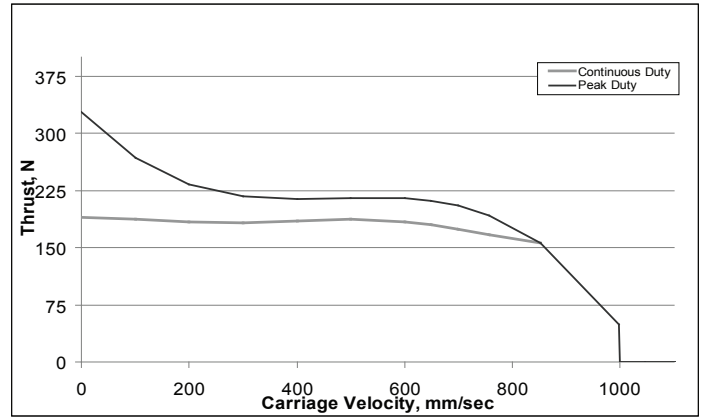

\*100 N Dynamic Thrust Limit for Basic Service Life when operated at critical speed limits within average speed requirements stated on page 26.

**VL-ST60 - SM2315DT @ 42V, 6mm/rev lead ball screw**

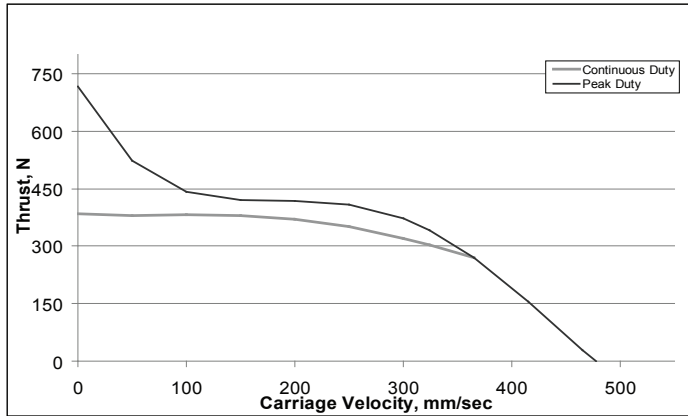

\*130 N Dynamic Thrust Limit for Basic Service Life when operated at critical speed limits within average speed requirements stated on page 26.

**VL-ST60 - SM2315DT @ 42V, 12mm/rev lead ball screw**

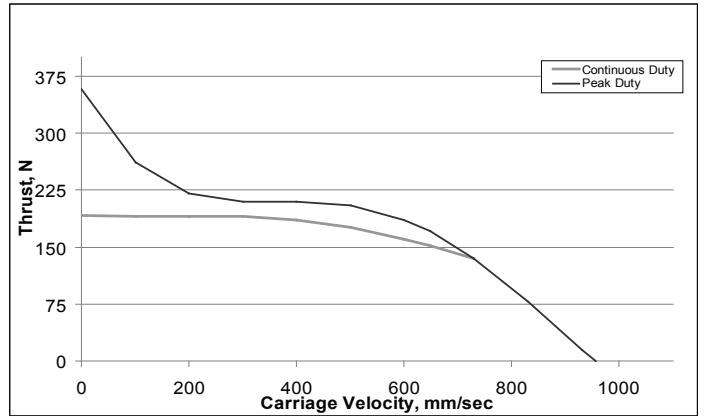

\*100 N Dynamic Thrust Limit for Basic Service Life when operated at critical speed limits within average speed requirements stated on page 26.

**VL-ST60 - SM2315DT @ 24V, 6mm/rev lead ball screw**

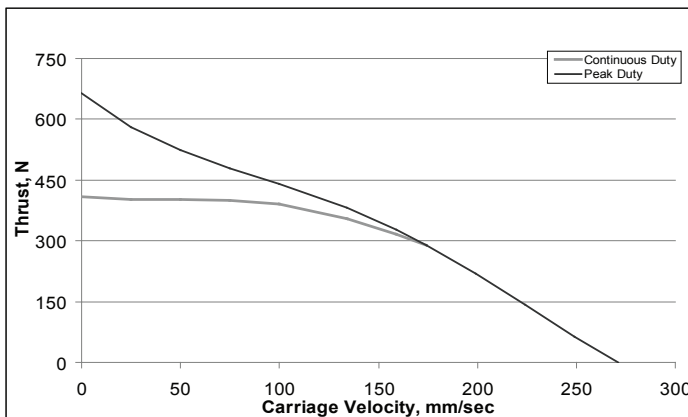

\*130 N Dynamic Thrust Limit for Basic Service Life when operated at critical speed limits within average speed requirements stated on page 26.

**VL-ST60 - SM2315DT @ 24V, 12mm/rev lead ball screw**

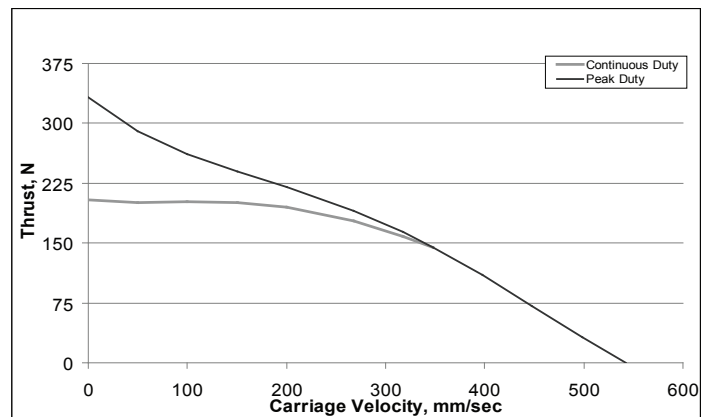

\*100 N Dynamic Thrust Limit for Basic Service Life when operated at critical speed limits within average speed requirements stated on page 26.

**VL-ST60 - SM2316D @ 48V, 6mm/rev lead ball screw**

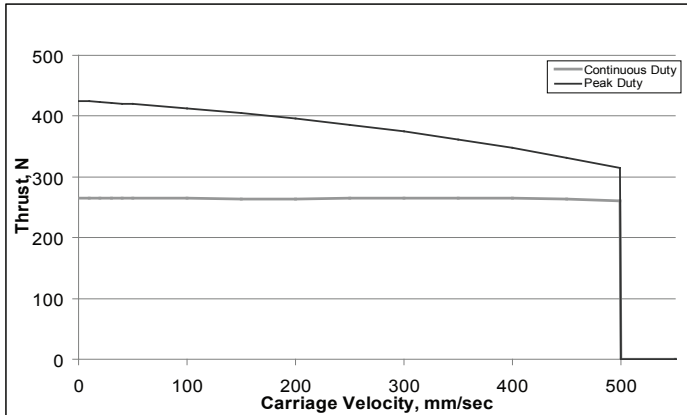

\*130 N Dynamic Thrust Limit for Basic Service Life when operated at critical speed limits within average speed requirements stated on page 26.

**VL-ST60 - SM2316D @ 48V, 12mm/rev lead ball screw**

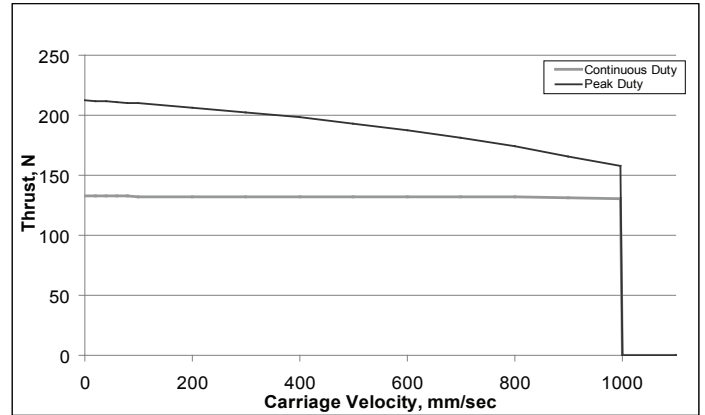

\*100 N Dynamic Thrust Limit for Basic Service Life when operated at critical speed limits within average speed requirements stated on page 26.

**VL-ST60 - SM2316D @ 42V, 6mm/rev lead ball screw**

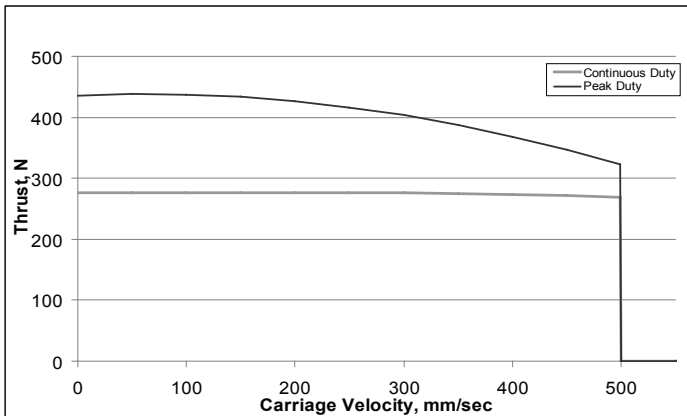

\*130 N Dynamic Thrust Limit for Basic Service Life when operated at critical speed limits within average speed requirements stated on page 26.

**VL-ST60 - SM2316D @ 42V, 12mm/rev lead ball screw**

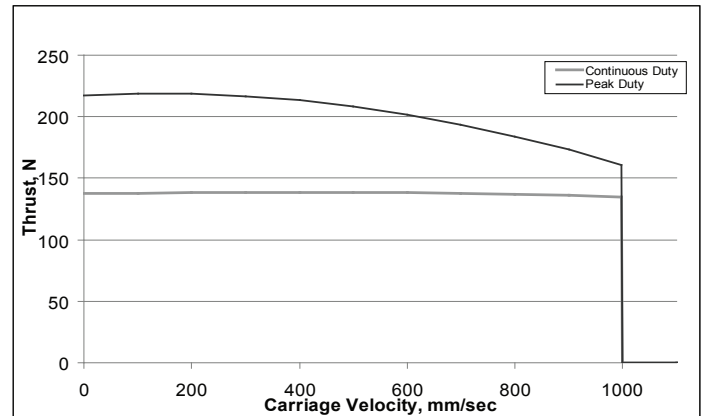

\*100 N Dynamic Thrust Limit for Basic Service Life when operated at critical speed limits within average speed requirements stated on page 26.

**VL-ST60 - SM2316D @ 24V, 6mm/rev lead ball screw**

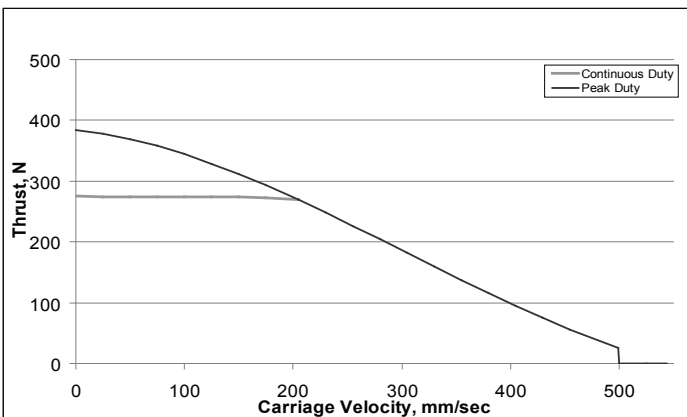

\*130 N Dynamic Thrust Limit for Basic Service Life when operated at critical speed limits within average speed requirements stated on page 26.

**VL-ST60 - SM2316D @ 24V, 12mm/rev lead ball screw**

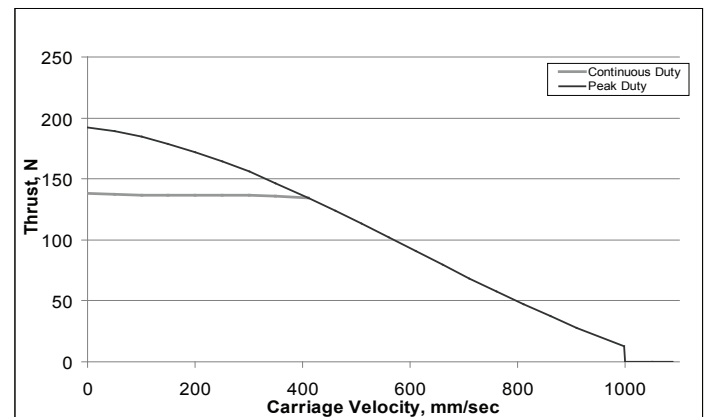

\*100 N Dynamic Thrust Limit for Basic Service Life when operated at critical speed limits within average speed requirements stated on page 26.

**VL-ST60 - SM2315D @ 48V, 6mm/rev lead ball screw**

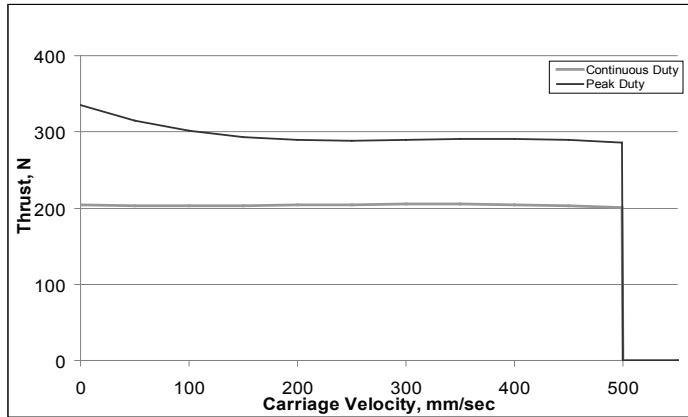

\*130 N Dynamic Thrust Limit for Basic Service Life when operated at critical speed limits within average speed requirements stated on page 26.

**VL-ST60 - SM2315D @ 48V, 12mm/rev lead ball screw**

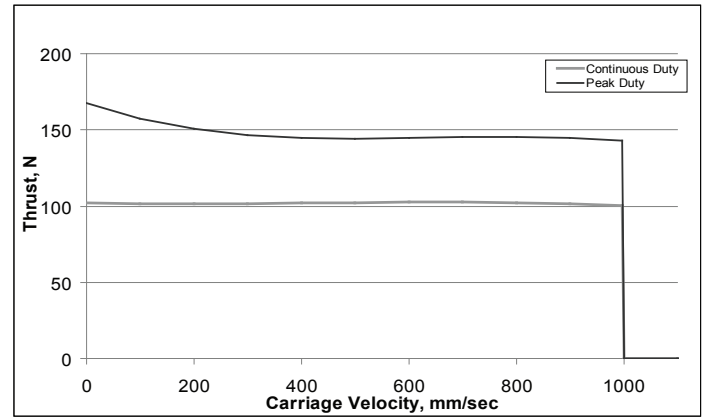

\*100 N Dynamic Thrust Limit for Basic Service Life when operated at critical speed limits within average speed requirements stated on page 26.

**VL-ST60 - SM2315D @ 42V, 6mm/rev lead ball screw**

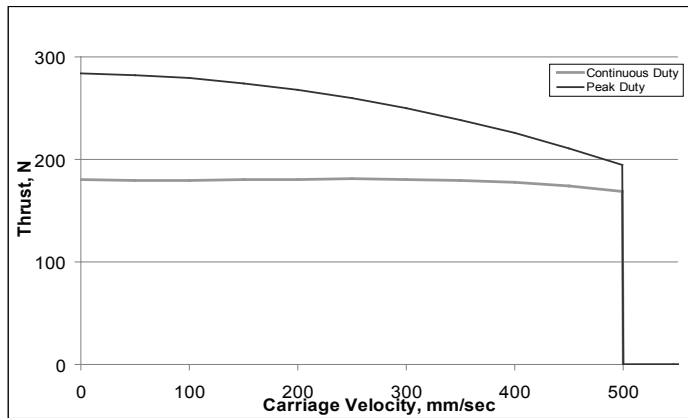

\*130 N Dynamic Thrust Limit for Basic Service Life when operated at critical speed limits within average speed requirements stated on page 26.

**VL-ST60 - SM2315D @ 42V, 12mm/rev lead ball screw**

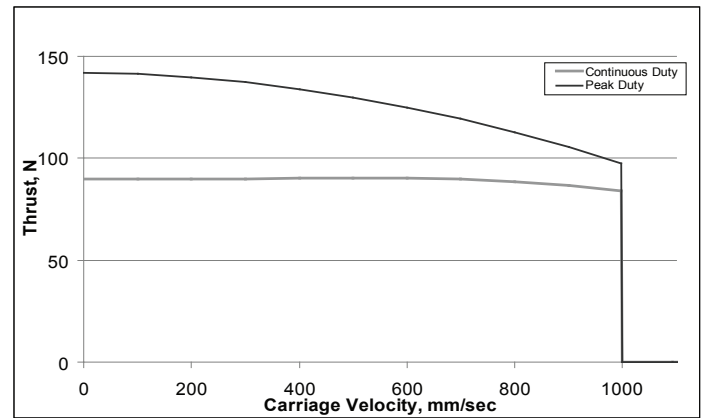

\*100 N Dynamic Thrust Limit for Basic Service Life when operated at critical speed limits within average speed requirements stated on page 26.

**VL-ST60 - SM2315D @ 24V, 6mm/rev lead ball screw**

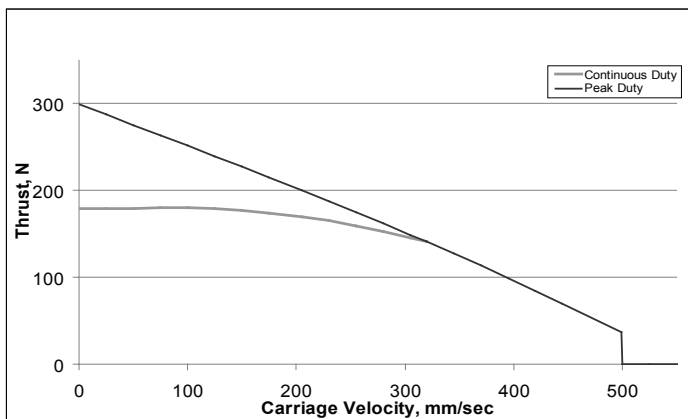

\*130 N Dynamic Thrust Limit for Basic Service Life when operated at critical speed limits within average speed requirements stated on page 26.

**VL-ST60 - SM2315D @ 24V, 12mm/rev lead ball screw**

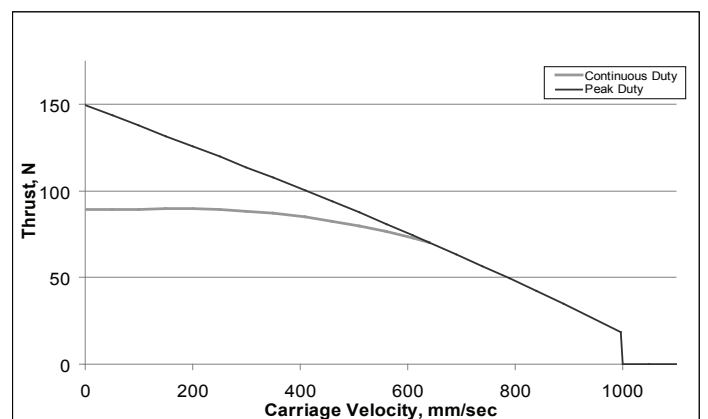

\*100 N Dynamic Thrust Limit for Basic Service Life when operated at critical speed limits within average speed requirements stated on page 26.